

■ Features

- Broad Band: 10.7 to 11.7GHz
- High Output Power: Pout=48.5dBm (Typ.)
- High Linear Gain : GL=10.0dB (Typ.)
- Hermetically Sealed Package
- Application for Point to Point

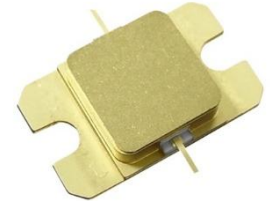

■ Description

The SGK1011-60C is a high power GaN-HEMT that is internally matched for standard communication bands to provide optimum power and gain in a 50ohm system.

ABSOLUTE MAXIMUM RATING (Case Temperature $T_c=25$ deg.C)

Item	Symbol	Rating	Unit
Drain-Source Voltage	V_{DS}	26	V
Gate-Source Voltage	V_{GS}	-10	V
Total Power Dissipation	P_T	173	W
Storage Temperature	T_{stg}	-55 to +125	deg.C
Channel Temperature	T_{ch}	+250	deg.C
Case Temperature	T_c	-40 to +125	deg.C

RECOMMENDED OPERATING CONDITION

Item	Symbol	Condition	Limit	Unit
Drain-Source Voltage	V_{DS}		24	V
Forward Gate Current	I_{GF}	Rg=51ohm	10.5	mA
Reverse Gate Current	I_{GR}	Rg=51ohm	-5.5	mA
Channel Temperature	T_{ch}		<+193	deg.C

Note:Electrical specifications are measured under specified test conditions. Not all recommended operating conditions can be guaranteed to meet specifications.

ELECTRICAL CHARACTERISTICS (Case Temperature $T_c=25$ deg.C)

Item	Symbol	Condition	Limit			Unit
			Min.	Typ.	Max.	
Saturated Drain Current	I_{DSS}	$V_{DS}=10V, V_{GS}=0V$	-	19	-	A
Trans Conductance	G_m	$V_{DS}=24V, I_{DS}=2.28A$	-	5.5	-	S
Pinch-off Voltage	V_P	$V_{DS}=24V, I_{DS}=2.28mA$	-2.5	-4.0	-5.5	V
Linear Gain at Pin=27dBm	GL	$V_{DS}=24V$ (typ.) $I_{DS(DC)}=2.6A$ (typ.) $f=10.7, 11.2, 11.7$ GHz	9.0	10.0	-	dB
Output Power at Pin=43dBm	P_{out}		47.0	48.5	-	dBm
Drain Current at Pin=43dBm	I_{DSR}		-	7.1	8.5	A
Power Added Efficiency at Pin=43dBm	PAE		-	35	-	%
Gain Flatness	ΔG		-	-	1.6	dB
Drain Current at Pout=43dBm	I_{DSR2}		-	3.5	4.0	A
3rd Order Inter Modulation Distortion	IM_3		$f=10.7, 11.2, 11.6$ GHz $\Delta f=120$ MHz, 2-tone Test Pout=32dBm (S.C.L.)	-35.0	-40.0	-
Thermal Resistance	R_{th}	Channel to Case ($T_c=25$ deg.C, $P_{diss}=62.4$ W)	-	1.1	1.3	deg.C/W
Channel Temperature Rise	ΔT_{ch}	$(V_{DS} \times I_{DSR} - P_{out} + Pin) \times R_{th_typ}$ @Pout=20W	-	96	-	deg.C

S.C.L. : Single Carrier Level

CASE STYLE	IBK
RoHS Compliance	YES
Shipping Tray	JEDEC Tray, 50 pcs max./Tray
ESD *1	Class 2
	2000V to < 4000V

Note : *1 Based on ANSI/ESDA/JEDEC JS-001(C=100pF, R=1.5kohm)

RF Characteristics

Power Derating Curve

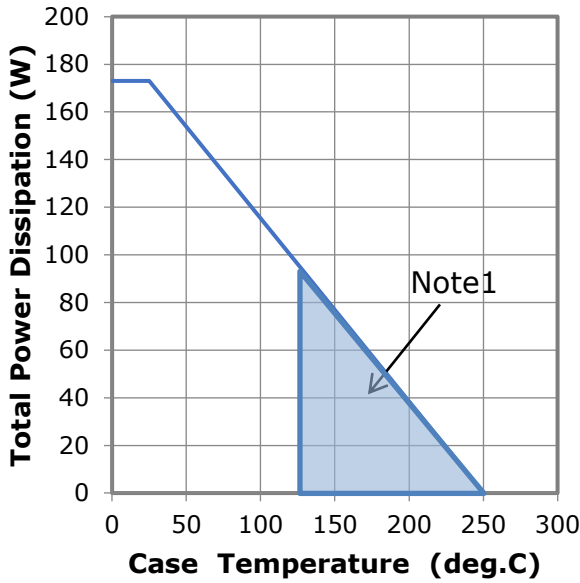

Note 1: Shaded area exceeds Maximum Case Operating Temperature (See Page1)

Output Power and Power Added Efficiency vs. Input Power

$V_{DS}=24V, I_{DS(DC)}=2.6A$

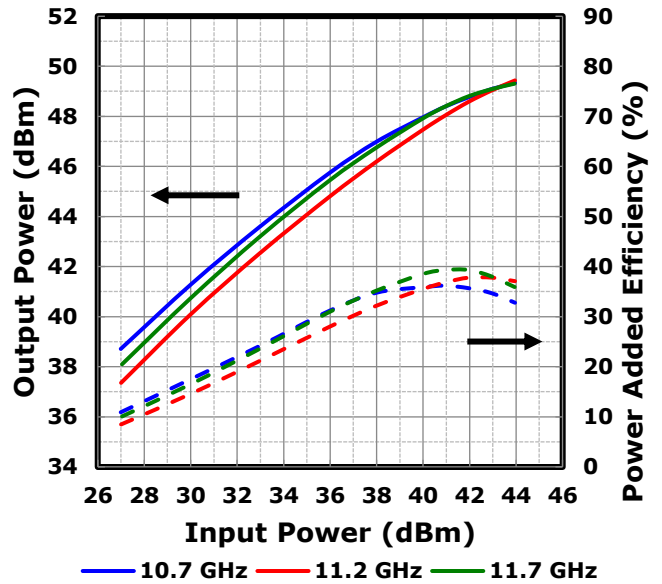

Output Power vs. Frequency

$V_{DS}=24V, I_{DS(DC)}=2.6A$

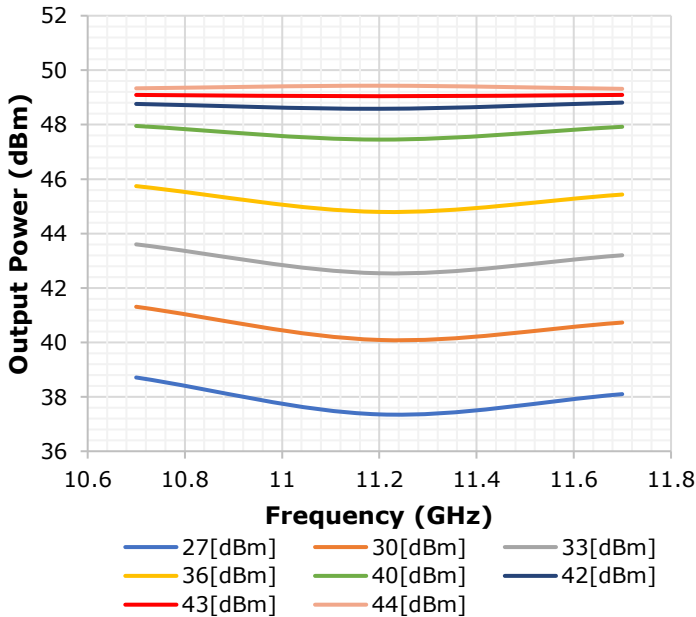

IMD vs. Output Power (S.C.L.)

$V_{DS}=24V, I_{DS(DC)}=2.6A, \Delta f=120MHz$

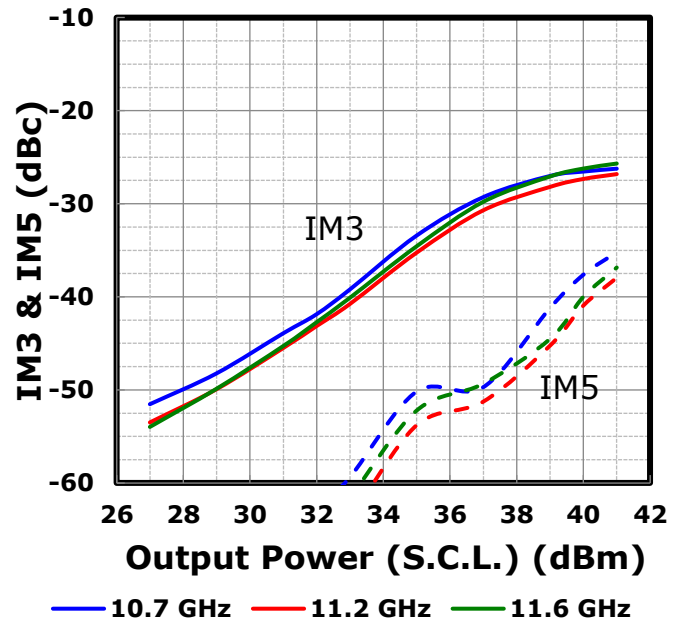

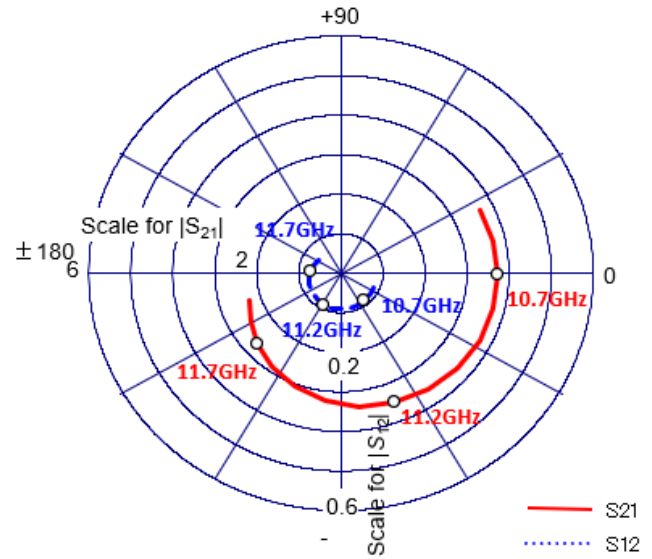
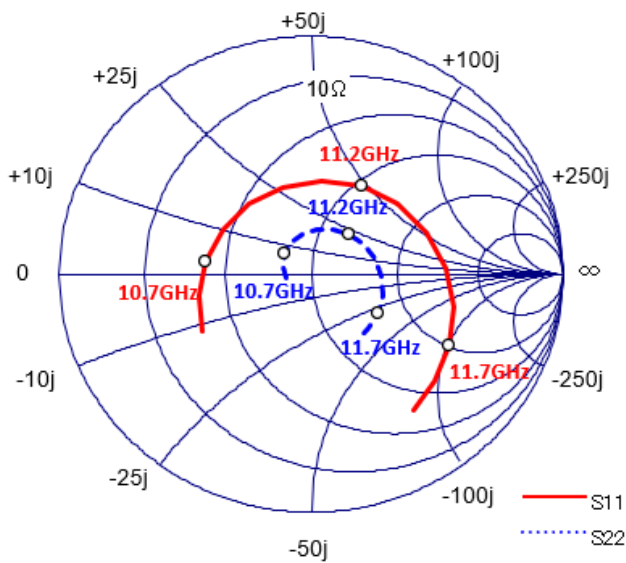
● S-Parameter

 Bias Condition $V_{DS}=24V, I_{DS(DC)}=2.6A$

Freq.	S11		S21		S12		S22	
	mag	phase	mag	phase	mag	phase	mag	phase
10.5GHz	0.495	-151.3	3.915	25.6	0.086	-25.7	0.100	-170.8
10.6GHz	0.455	-168.2	3.961	12.7	0.088	-38.0	0.115	162.8
10.7GHz	0.422	173.0	3.986	-0.3	0.089	-50.6	0.134	140.6
10.8GHz	0.397	152.3	3.994	-13.6	0.091	-63.4	0.154	120.9
10.9GHz	0.384	130.2	3.978	-27.1	0.091	-76.6	0.173	102.0
11.0GHz	0.382	107.2	3.935	-40.8	0.091	-89.8	0.191	84.1
11.1GHz	0.395	84.1	3.867	-54.7	0.090	-103.3	0.209	66.2
11.2GHz	0.419	61.8	3.765	-68.8	0.089	-116.9	0.226	48.4
11.3GHz	0.453	40.6	3.634	-82.8	0.087	-130.6	0.245	31.2
11.4GHz	0.492	20.9	3.474	-96.9	0.083	-144.5	0.262	14.3
11.5GHz	0.535	2.7	3.285	-110.7	0.080	-158.3	0.280	-1.9
11.6GHz	0.580	-13.9	3.078	-124.3	0.076	-171.9	0.297	-17.2
11.7GHz	0.623	-28.9	2.863	-137.4	0.071	174.7	0.312	-31.6
11.8GHz	0.664	-42.3	2.652	-150.1	0.066	162.1	0.323	-44.8
11.9GHz	0.702	-54.5	2.446	-162.4	0.061	149.5	0.330	-57.1

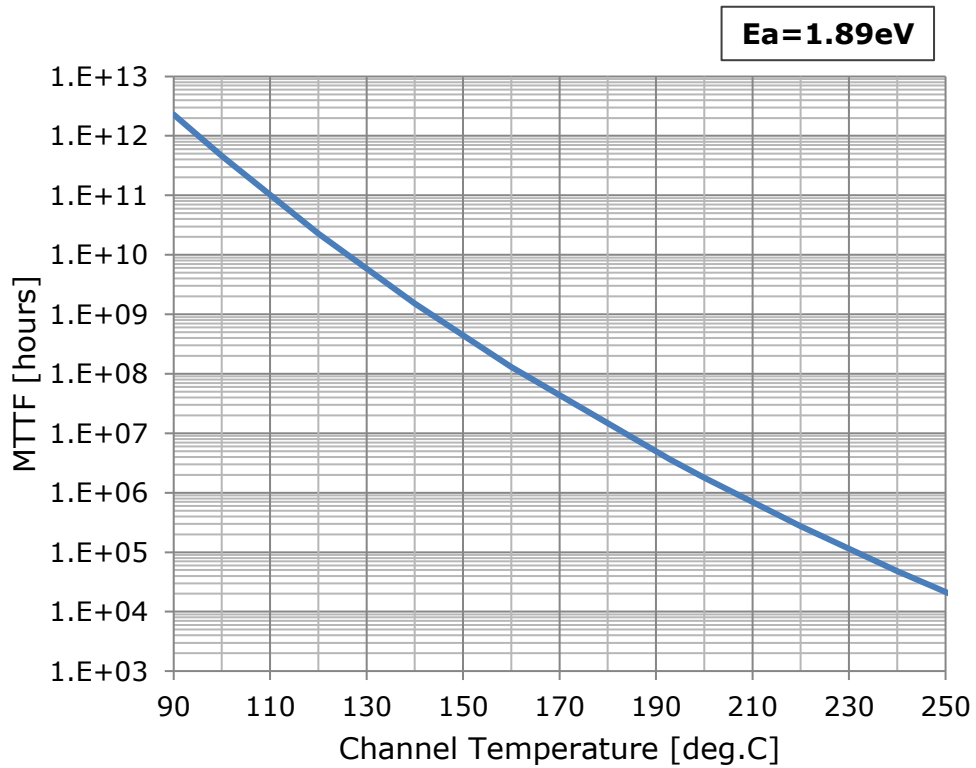
● **MTTF vs. Tch**

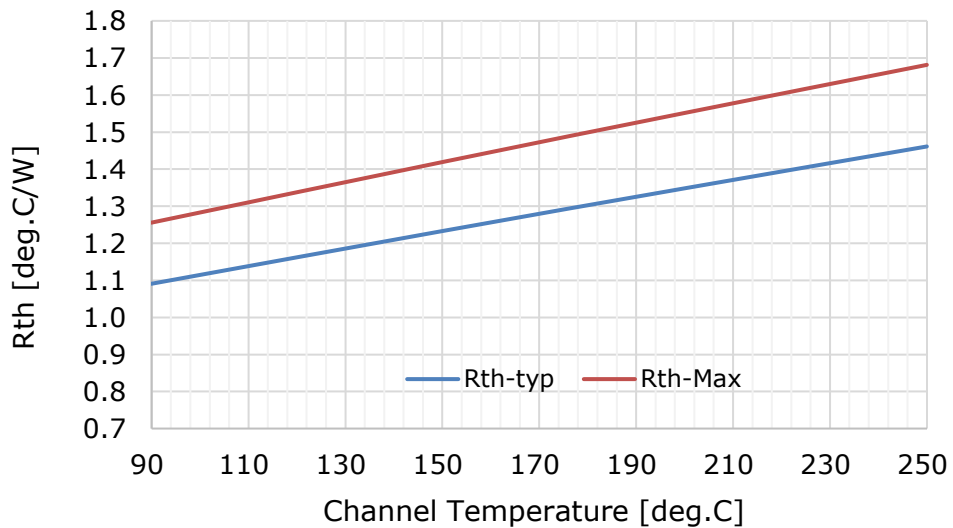

● **Rth vs. Tch**



● **Test Fixture of Evaluation Board (Reference)**

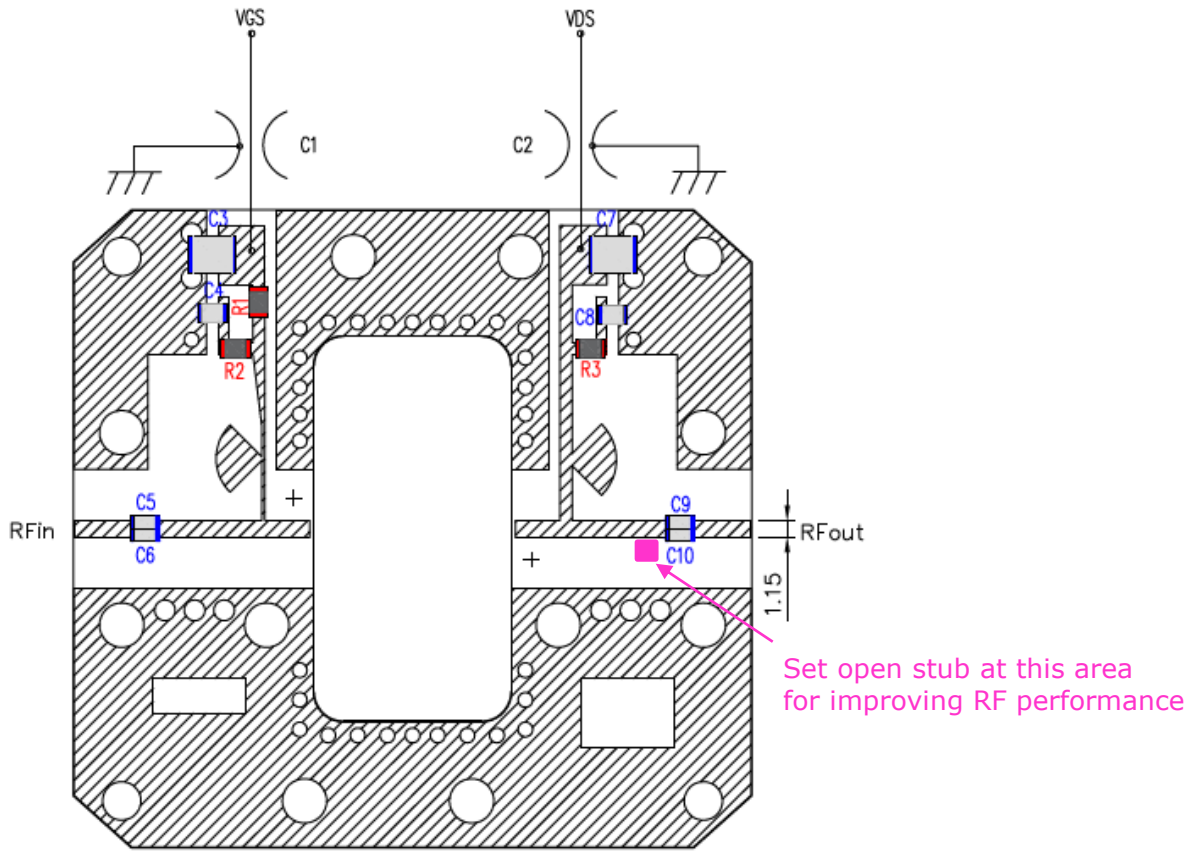

Part Index	Description	Size (mm)	Manufacturer	Part Number
C1,C2	1000pF		Maruwa	FTA352AR102S-S
C3	0.22uF	3225M	Murata	GRM32DR72E224KW01L
C4,C8	1000pF	2012M	Murata	GRM21AR72E102KW01D
C5,C6,C9,C10	1.0pF	2012M	Murata	GQM2195C2E1R0CB12D
C7	4.7uF	3225M	Murata	GRM32DC72A475ME01L
R1,R2,R3	51Ω	2012M	Panasonic	ERJ6GEYJ510V
PCB	Rogers R04003C t=0.508mm(20mil)			

Bill of Materials

● **Package Outline**

Case Style : IBK

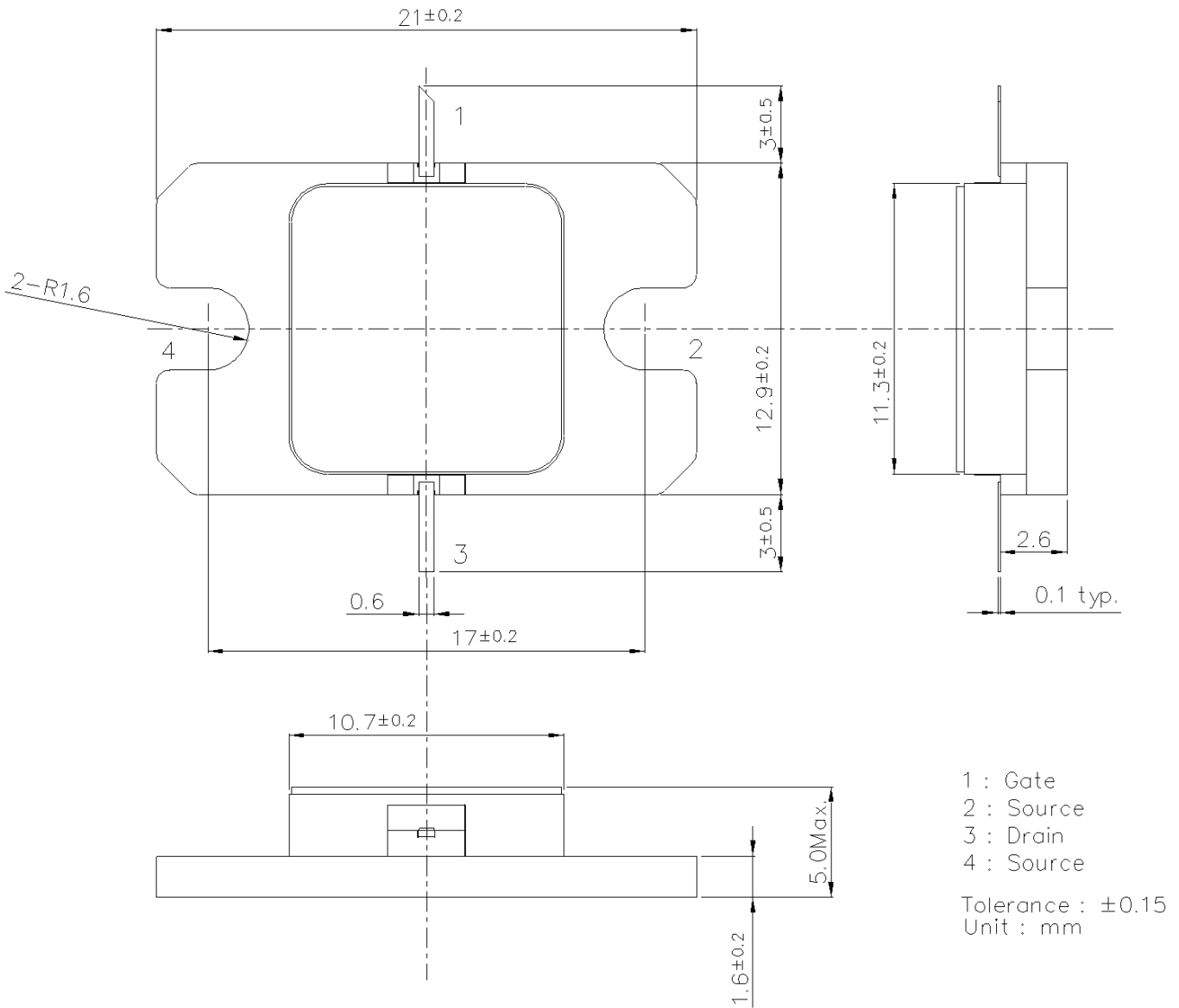

● Mounting Instructions for Packaged FETs

1. Screw Mounting

- (1) The flange of package may be attached using screws. Torque conditions are shown in table 1.

Table1. Recommended and Maximum Torque for Screw Mounting

Package	Recommended Screws	Recommended Torque	Maximum Torque
IB, IBK, IZZ	M3.0	45 N-cm (4.0 in lbf)	50 N-cm (4.4 in lbf)

- (2) The surface finish of the heat sink should be better than 0.8 μm , and the surface flatness must be better than 20 μm .
- (3) Silicon based heat sink compounds should not be used for the thermal conductive grease. They cause poor grounding of the source flange, contamination and long term degradation of thermal resistance between the FET package and heat sink.
- (4) If customers have use of thermal compounds and limited interface materials placed between the package flange and the heatsink to provide thermal transfer, any use of such materials is done at the customer's own risk and must be properly evaluated. Sumitomo Electric uses Panasonic carbon graphite sheet for mounting our devices. Our recommended sheet is EYGS182310. Recommended thickness is 0.1mm. Thermal conductivity is about 700 W/mK in the x-y direction. In the Z direction is about 15 W/mK.

2. Soldering for Gate and Drain Terminals

- (1) Recommended solder are Tin-Lead solder (63Sn/37Pb), Lead-Free solder (Sn-3.0Ag-0.5Cu)*¹ or equivalent.
- (2) For soldering, Tin-Lead solder (63Sn/37Pb) or Lead-Free solder (Sn-3.0Ag-0.5Cu)*¹ shall be used. (*1: The figure displays with weight %. A predominantly tin-rich alloy with 3.0% silver and 0.5% copper.)
- (3) Recommended Flux is Rosin type with chlorine content: 0.2% or less and a low halogen content. After soldering, the flux residue should be removed by appropriate cleaning methods.
- (4) The following is shown the recommended soldering conditions.

* Partial heating method (soldering iron, spot laser/air)

Product terminal temperature: 260 deg.C, max 10 s / terminal or 400 deg.C, max 3 s / terminal

Caution1: Soldering iron must be connected to the ground.

Caution2: Do not rapid cooling the devices.

Notes & Disclaimer

- Do not put this product into the mouth.
- Do not alter the form of this product into a gas, powder, or liquid through burning, crushing, or chemical processing as these by-products are dangerous to the human body if inhaled, ingested, or swallowed.
- Respect all applicable laws of the country when discarding this product.
This product must be disposed in accordance with methods specified by applicable hazardous waste procedures.

Any information in this document, such as descriptions of a function and examples of application circuits ("Reference Information"), are presented solely as a reference for the purpose to show examples of operations and uses of Sumitomo Electric semiconductor device(s); Sumitomo Electric does not warrant that the device(s) function as described in Reference Information. When the user develops equipment incorporating the device(s) by referencing Reference Information, the user shall assume full responsibility arising out of such development, incorporation of the device(s), or use of Reference Information. Sumitomo Electric assumes no liability for any damages whatsoever arising out of such development, incorporation of the device(s), or use of Reference Information.

YOU HEREBY AGREE THAT BY PURCHASING THE SUMITOMO ELECTRIC GROUP PRODUCTS ("SEG PRODUCTS") DESCRIBED IN THIS DOCUMENT, YOU ARE DEEMED TO HAVE AGREED TO THE FOLLOWING:

- **SEG PRODUCTS IMPLEMENTED IN YOUR MANUFACTURING PROCESS SHALL BE FULLY EVALUATED IN YOUR PRODUCT OR SYSTEM NOT ONLY INITIAL PERFORMANCE BUT ALSO LONG-TERM-RELIABILITY, AND YOU SHALL DETERMINE THE APPLICABILITY OF SEG PRODUCTS AT YOUR OWN RESPONSIBILITY.**
- **YOU SHALL BE RESPONSIBLE FOR ALL LOSSES, EXPENSES, OR DAMAGES RESULTING FROM ANY DEFECTS IN THE SEG PRODUCTS ARISING FROM YOUR HANDLING, ASSEMBLY AND IMPLEMENTATION PROCESS.**

Any information in this document, including descriptions of function and schematic diagrams, shall not be construed as a license for the use or exercise of any intellectual property right, such as patent right or copyright, or any other right of Sumitomo Electric or any third party nor does Sumitomo Electric warrant non-infringement of any third-party's intellectual property right or other right by using such information. Sumitomo Electric assumes no liability for any infringement of the intellectual property rights or other rights of third parties which would result from the use of information contained herein.

The products described in this document are designed, developed and manufactured as contemplated for general use, including, without limitation, ordinary industrial use, general office use, personal use, and household use, but are not designed, developed and manufactured as contemplated (1) for use accompanying fatal risks or dangers that, unless extremely high safety is secured, could have a serious effect to the public, and could lead directly to death, personal injury, severe physical damage or other loss (i.e., nuclear reaction control in nuclear facility, aircraft flight control, air traffic control, mass transport control, medical life support system, missile launch control in weapon system), or (2) for use requiring extremely high reliability (i.e., submersible repeater and artificial satellite).

Please note that Sumitomo Electric will not be liable to the user and/or any third party for any claims or damages arising from the aforementioned uses of the products.

Any semiconductor devices have an inherent chance of failure. You must protect against injury, damage or loss from such failures by incorporating safety design measures into your facility and equipment such as redundancy, fire protection, and prevention of excessive current levels and other abnormal operating conditions.

If any products described in this document represent goods or technologies subject to certain restrictions on export under the Foreign Exchange and Foreign Trade Law of Japan, the prior authorization of the Japanese government will be required for export of those products from Japan.

<https://www.sedi.co.jp/>

ATTENTION

Information in this document is subject to change without notice.