

SMM5846V1D

Ka-Band Power Amplifier MMIC

FEATURES

- High Output Power: Pout=31.5dBm (typ.)
- Linear Gain: GL=20.0dB (typ.)
- Frequency Band: 27.5 to 29.5GHz
- Impedance Matched Zin/Zout=50ohm
- Small Hermetic Metal-Ceramic SMT Package(V1D)

DESCRIPTION

The SMM5846V1D is a MMIC amplifier that contains a four-stages amplifier, internally matched, for standard communications band in the 27.5 to 29.5GHz frequency range. This product is well suited for Ka-band point to point radio communication.

SUMITOMO ELECTRIC 's stringent Quality Assurance Program assures the highest reliability and consistent performance.

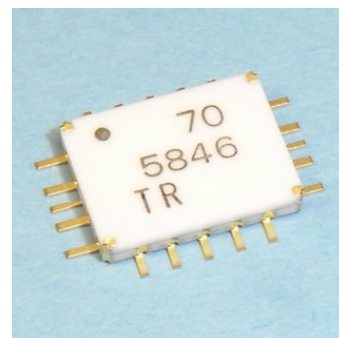

ABSOLUTE MAXIMUM RATING

Item	Symbol	Rating	Unit
DC Positive Supply Voltage	V _{DD}	10	V
DC Negative Supply Voltage	V _{GG}	-3	V
Input Power	P _{in}	+22	dBm
Storage Temperature	T _{stg}	-55 to +125	deg.C

RECOMMENDED OPERATING CONDITIONS

Item	Symbol	Recommend	Unit
DC Positive Supply Voltage	V _{DD}	up to 6	V
Input Power	P _{in}	up to +16	dBm
Operating Case Temperature	T _C	-40 to +85	deg.C

ELECTRICAL CHARACTERISTICS (Case Temperature Tc=25deg.C)

Item	Symbol	Test Conditions	Limits			Unit
			Min.	Typ.	Max.	
RF Frequency Range	f	V _{DD} =+6V	27.5	-	29.5	GHz
Gate Bias Voltage	V _{GG}	I _{DD} =1100mA typ.	-0.50	-	-0.04	V
Output Power at 13dBm Input	P _{OUT}	V _{GG} -constant	29.5	31.5	-	dBm
Output Power at 1dB G.C.P.	P _{1dB}	Z _S =Z _L =50ohm	-	31	-	dBm
Power Gain at 1dB G.C.P.	G _{1dB}		16	19	-	dB
Power-added Efficiency at 1dB G.C.P.	N _{add}		-	15	-	%
Third Order Intermodulation*	IM ₃	*:Δf=10MHz ,	38	42	-	dBc
Output Third Order Intercept Point*	OIP ₃	2-Tone Test,	-	39	-	dBm
Drain Current at 1dB G.C.P.	I _{DDRF}	P _{out} =18dBm S.C.L.	-	1450	1850	mA
Input Return Loss (at Pin=-20dBm)	RL _{IN}		-	-10	-	dB
Output Return Loss (at Pin=-20dBm)	RL _{OUT}		-	-10	-	dB

G.C.P.:Gain Compression Point

S.C.L.:Single Carrier Level

ESD	Class 0	up to 250V
------------	----------------	-------------------

Note: Based on JEDEC JESD22-A114-C (C=100pF, R=1.5kohm)

CASE STYLE	V1D
RoHS Compliance	Yes

Ordering Information

Part Number	Order Unit	Packing
SMM5846V1D	No Limitation	48 pcs. / Tray X 4 Trays = 192 pcs. / Packing
SMM5846V1DT		N.A.

Output Power, Drain Current vs. Input Power

@VDD=6V, IDD(DC)=1100mA

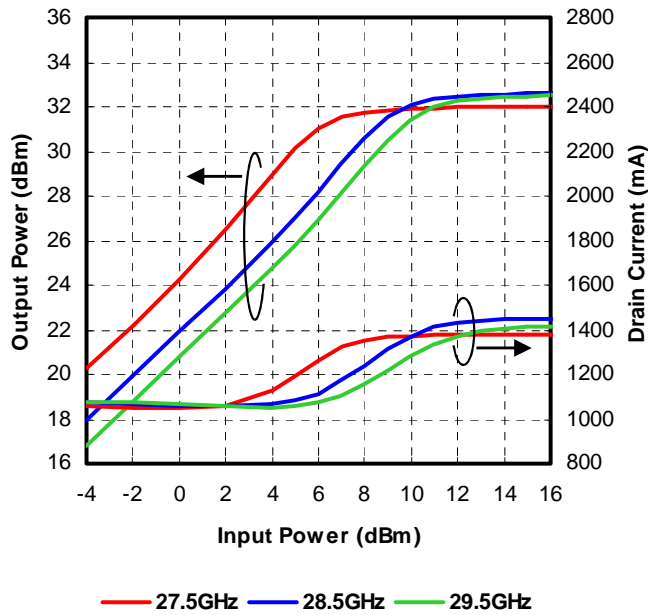

Output Power vs. Frequency

@VDD=6V, IDD(DC)=1100mA

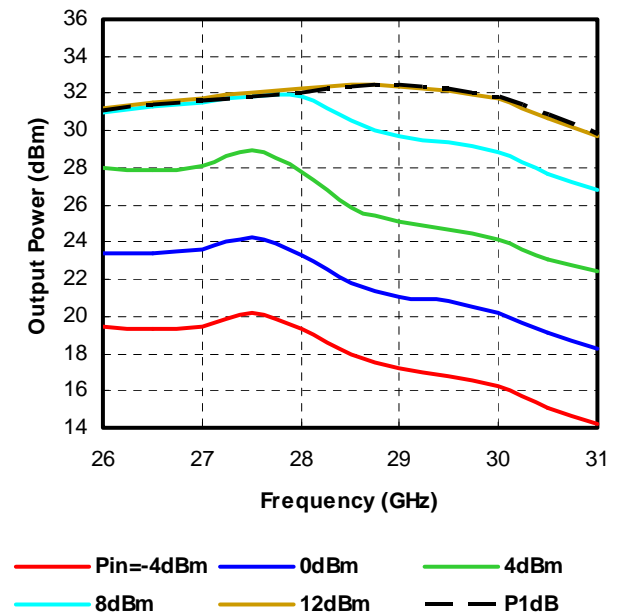

IMD Performance vs. Output Power

@VDD=6V, IDD(DC)=1100mA

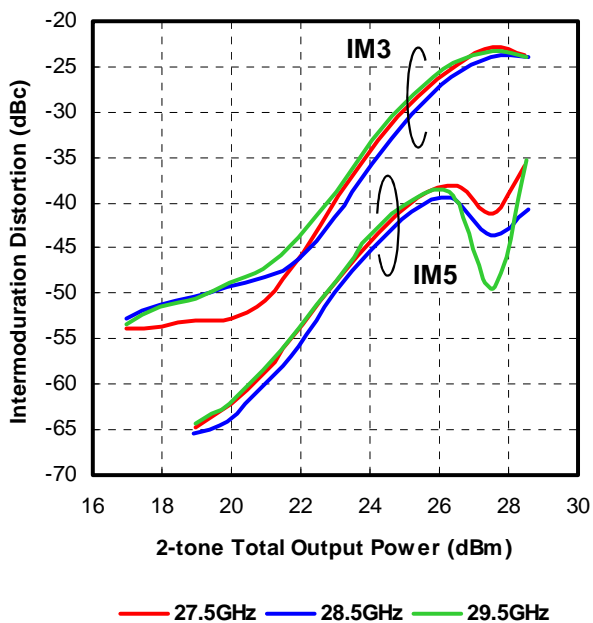

IM3 Performance vs. Frequency

@VDD=6V, IDD(DC)=1100mA

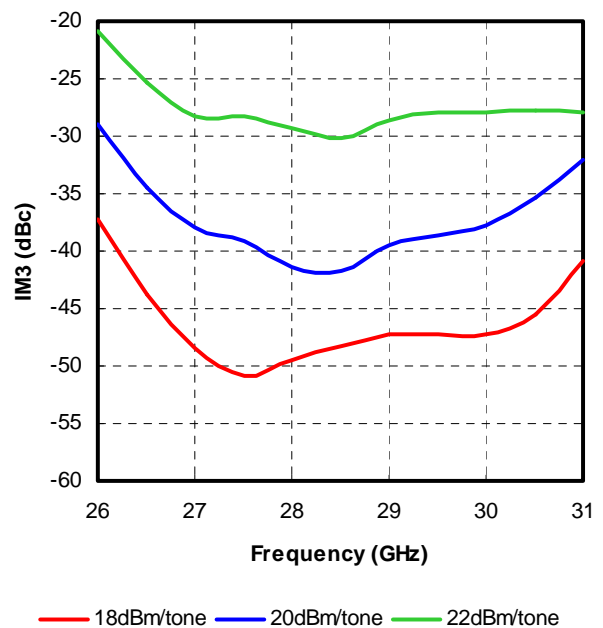

Output Power, Drain Current vs. Input Power by Drain Voltage

@IDD(DC)=1100mA, Freq=27.5GHz

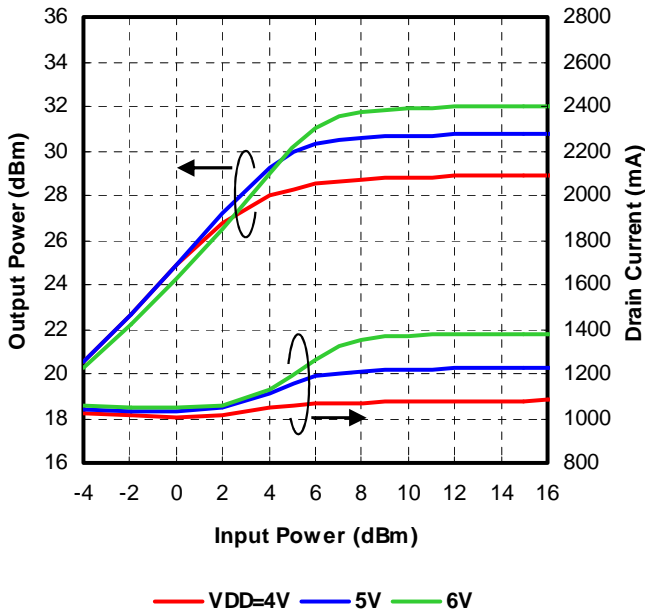

Output Power, Drain Current vs. Input Power by Drain Voltage

@IDD(DC)=1100mA, Freq=28.5GHz

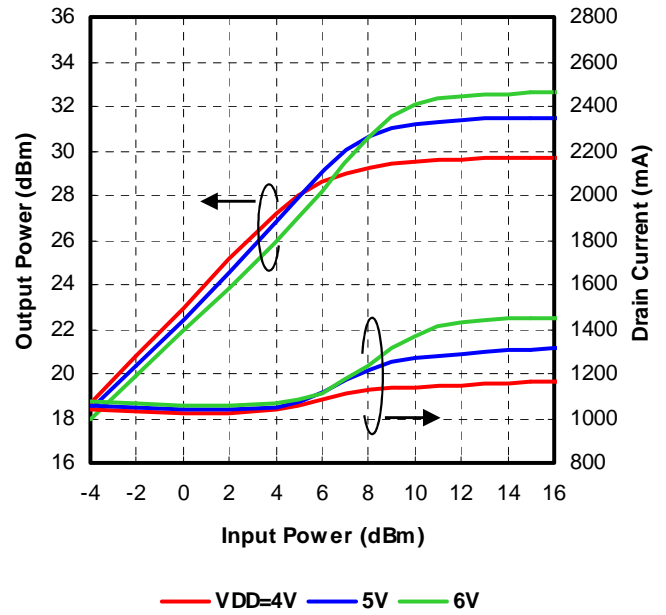

Output Power, Drain Current vs. Input Power by Drain Voltage

@IDD(DC)=1100mA, Freq=29.5GHz

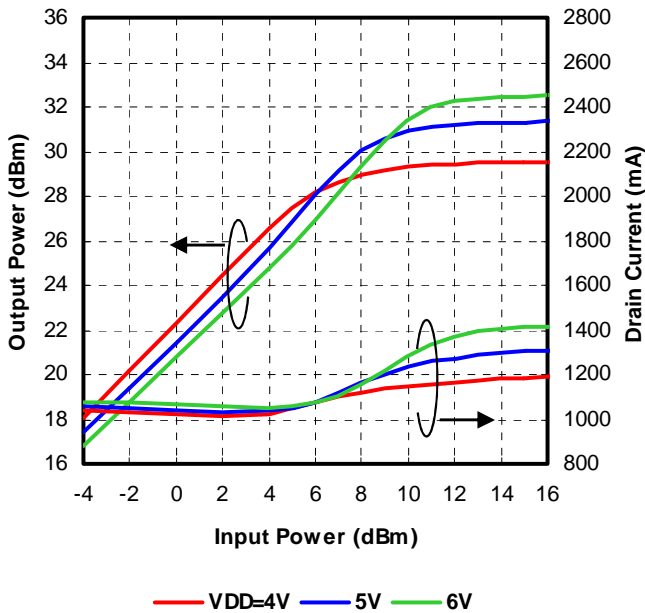

P1dB, G1dB vs. Frequency by Drain Voltage

@IDD(DC)=1100mA

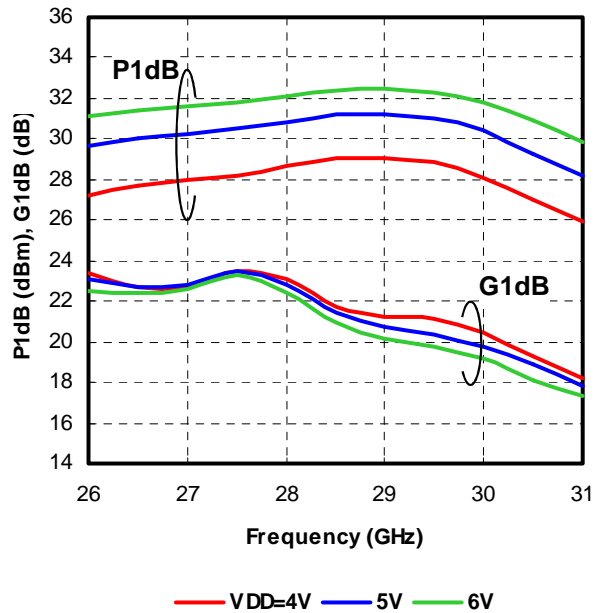

Output Power, Drain Current vs. Input Power by Drain Current

@IDD(DC)=1100mA, Freq=27.5GHz

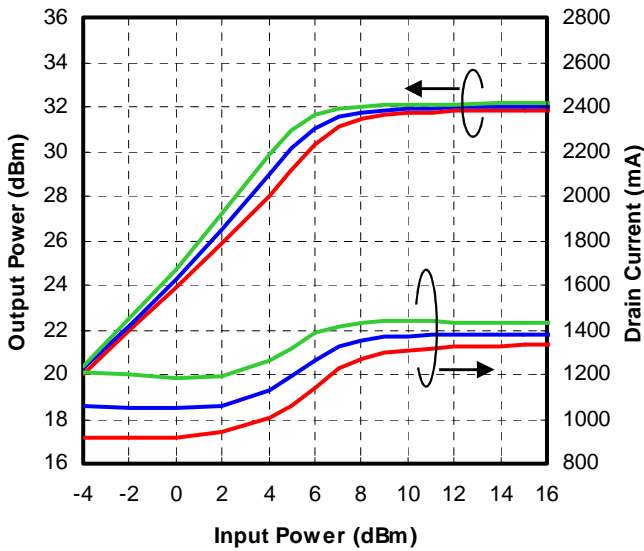

— IDD(DC)=950mA — 1100mA — 1250mA

Output Power, Drain Current vs. Input Power by Drain Current

@IDD(DC)=1100mA, Freq=28.5GHz

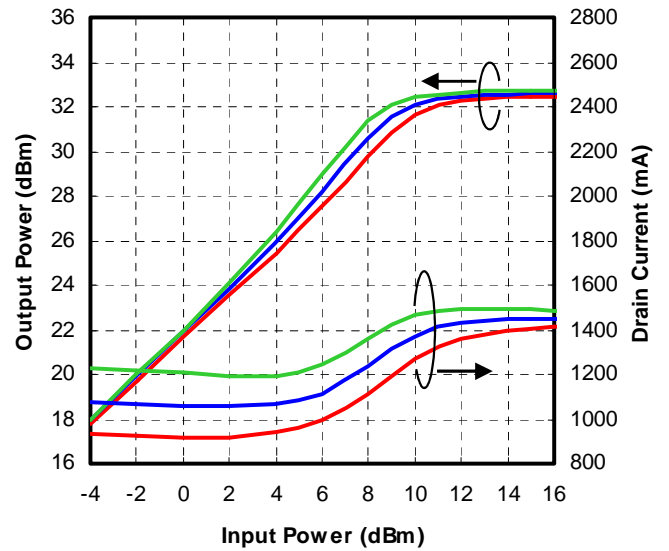

— IDD(DC)=950mA — 1100mA — 1250mA

Output Power, Drain Current vs. Input Power by Drain Current

@IDD(DC)=1100mA, Freq=29.5GHz

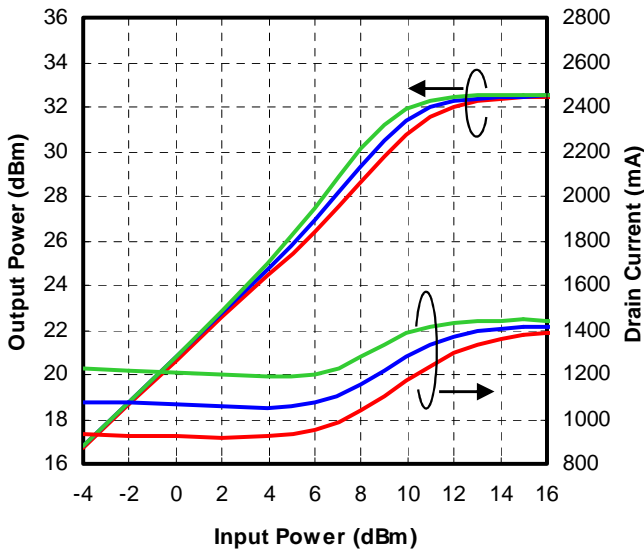

— IDD(DC)=950mA — 1100mA — 1250mA

P1dB, G1dB vs. Frequency by Drain Current

@VDD=6V

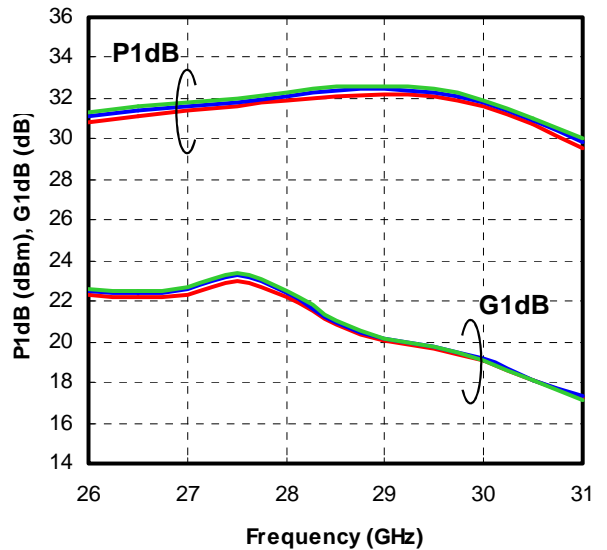

— IDD(DC)=950mA — 1100mA — 1250mA

Output Power, Drain Current vs. Input Power by Case Temperature

@VDD=6V, IDD=1100mA(@Tc=+25deg.C), Freq=27.5GHz

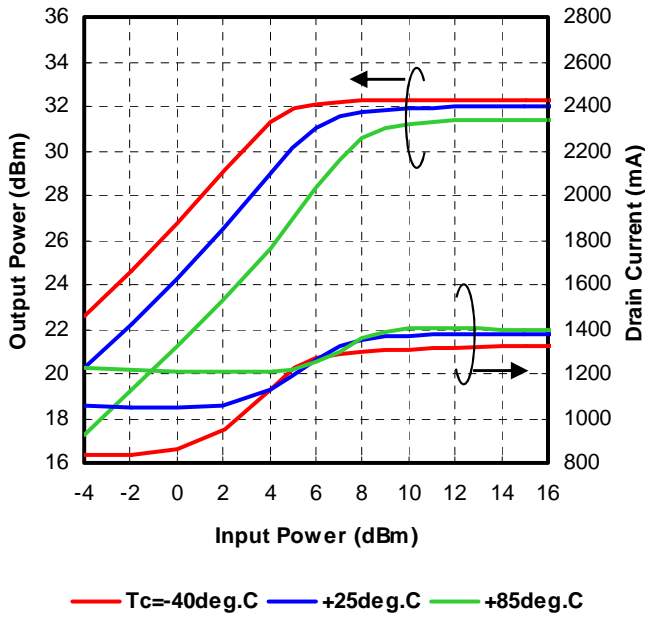

Output Power, Drain Current vs. Input Power by Case Temperature

@VDD=6V, IDD=1100mA(@Tc=+25deg.C), Freq=28.5GHz

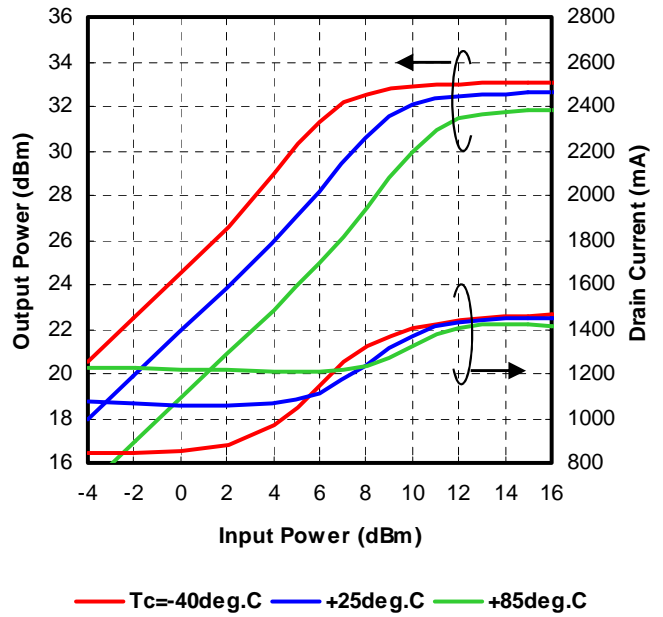

Output Power, Drain Current vs. Input Power by Case Temperature

@VDD=6V, IDD=1100mA(@Tc=+25deg.C), Freq=29.5GHz

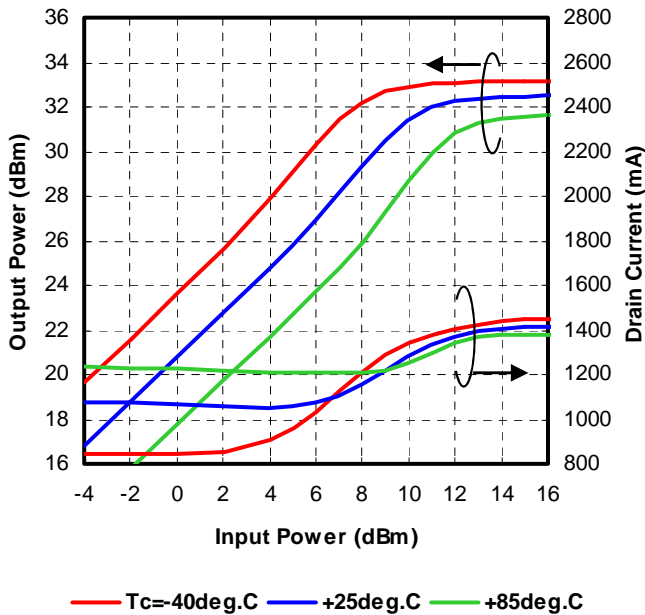

P1dB, G1dB vs. Frequency by Case Temperature

@VDD=6V, IDD=1100mA(@Tc=+25deg.C)

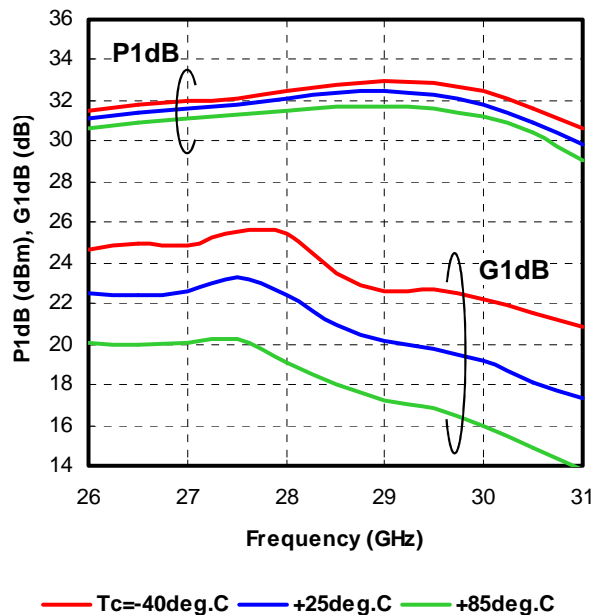

Inter-modulation Distortion vs. Output Power by Drain Voltage

@IDD(DC)=1100mA, Freq=27.5GHz

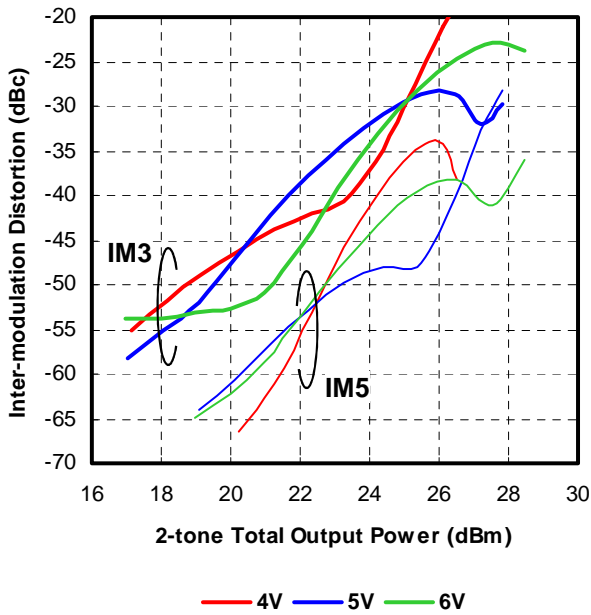

Inter-modulation Distortion vs. Output Power by Drain Voltage

@IDD(DC)=1100mA, Freq=28.5GHz

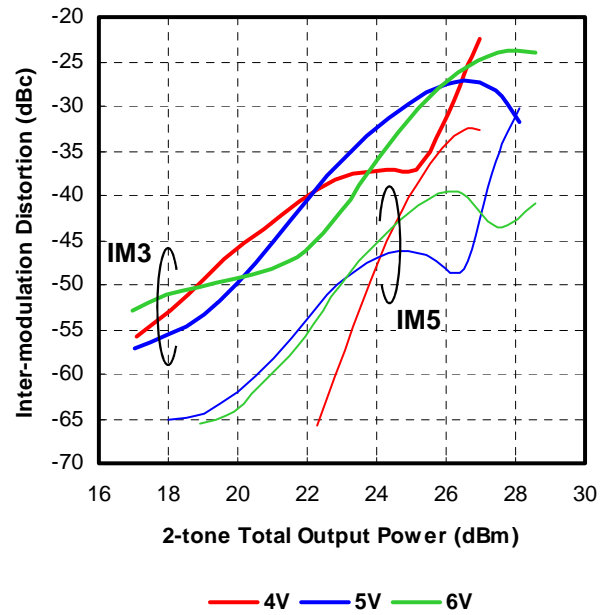

Inter-modulation Distortion vs. Output Power by Drain Voltage

@IDD(DC)=1100mA, Freq=29.5GHz

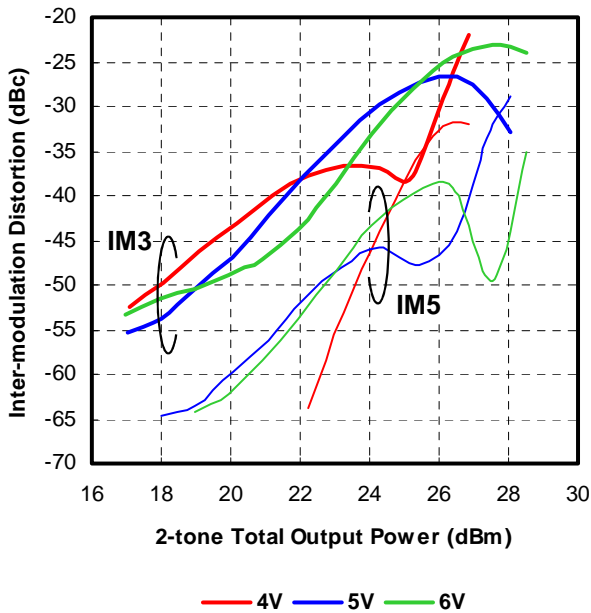

Inter-modulation Distortion vs. Frequency by Drain Voltage

@IDD(DC)=1100mA, Pout=18dBm/tone

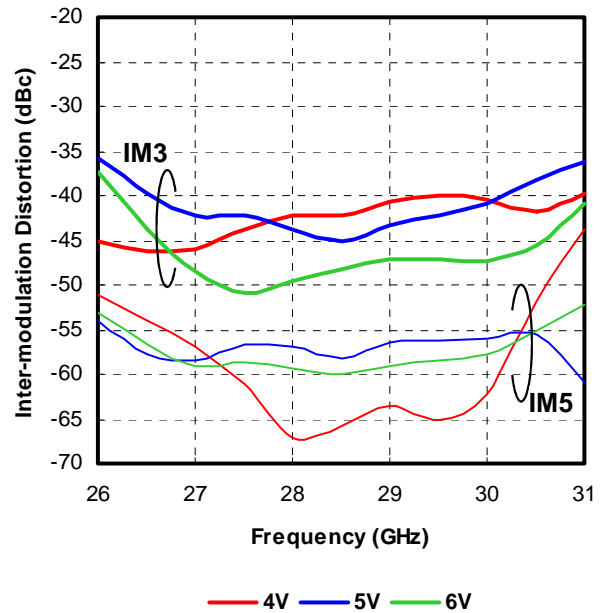

Inter-modulation Distortion vs. Output Power by Drain Current

@IDD(DC)=1100mA, Freq=27.5GHz

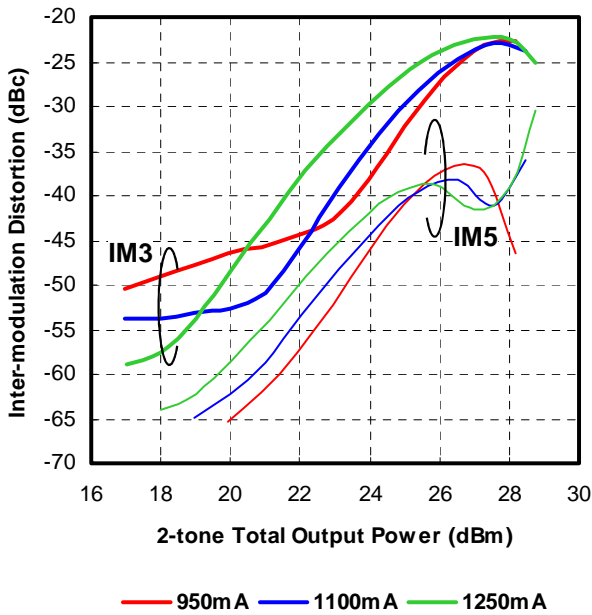

Inter-modulation Distortion vs. Output Power by Drain Current

@IDD(DC)=1100mA, Freq=28.5GHz

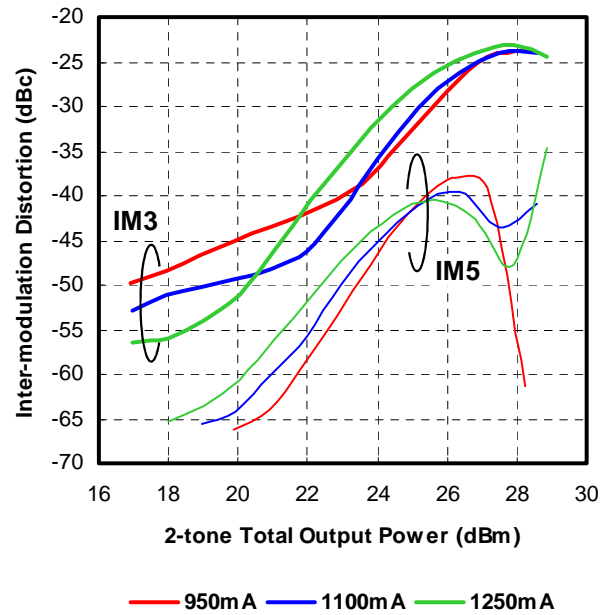

Inter-modulation Distortion vs. Output Power by Drain Current

@IDD(DC)=1100mA, Freq=29.5GHz

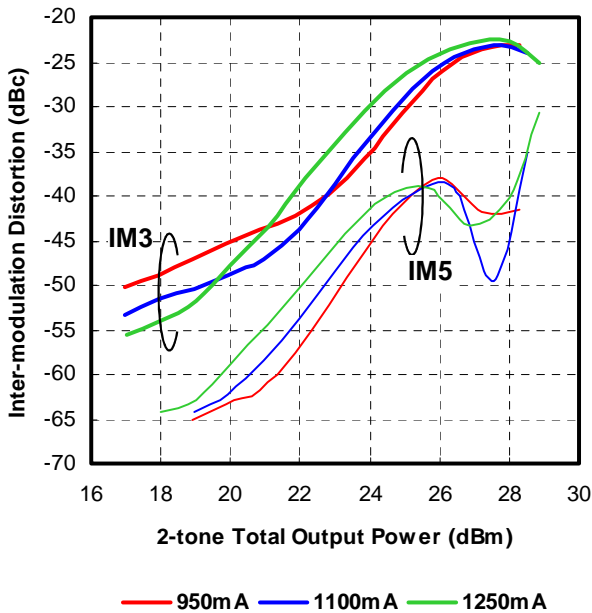

Inter-modulation Distortion vs. Frequency by Drain Current

@VDD=6V, Pout=18dBm/tone

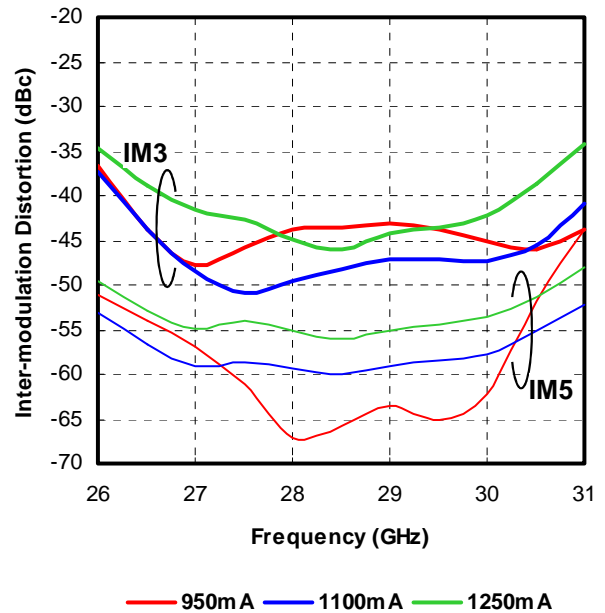

Inter-modulation Distortion vs. Output Power by Case Temperature

@VDD=6V, IDD=1100mA(@Tc=+25deg.C), Freq=27.5GHz

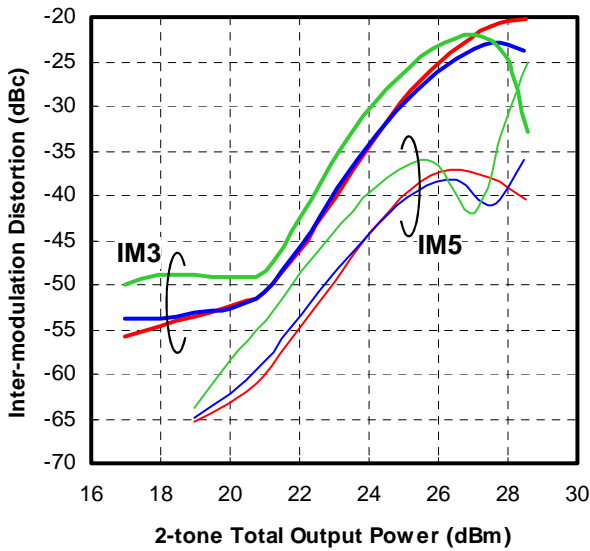

— Tc=-40deg.C — +25deg.C — +85deg.C

Inter-modulation Distortion vs. Output Power by Case Temperature

@VDD=6V, IDD=1100mA(@Tc=+25deg.C), Freq=28.5GHz

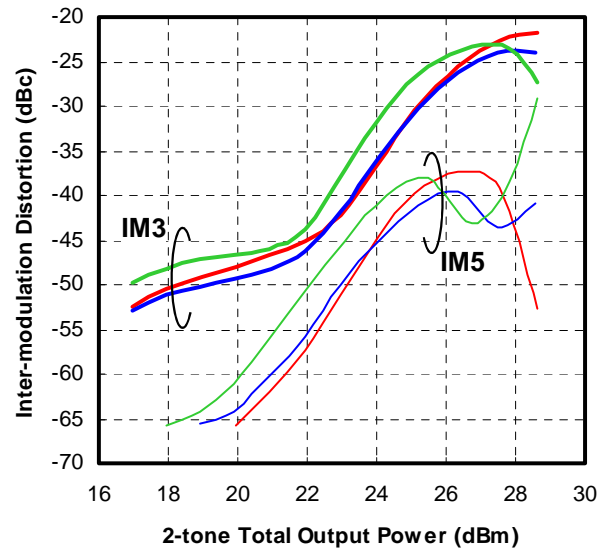

— Tc=-40deg.C — +25deg.C — +85deg.C

Inter-modulation Distortion vs. Output Power by Case Temperature

@VDD=6V, IDD=1100mA(@Tc=+25deg.C), Freq=29.5GHz

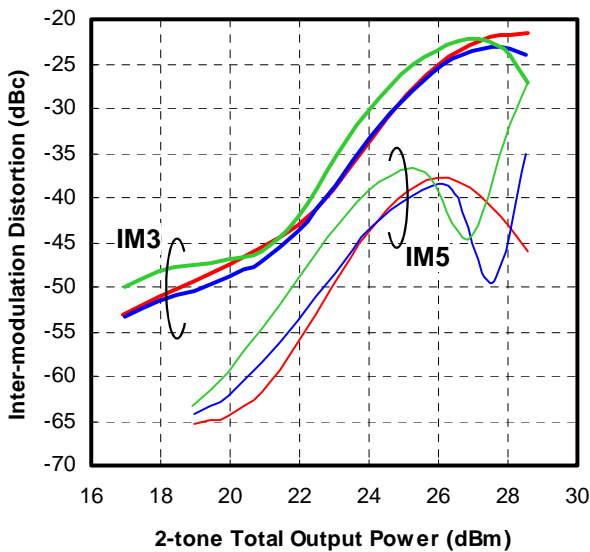

— Tc=-40deg.C — +25deg.C — +85deg.C

Inter-modulation Distortion vs. Frequency by Case Temperature

@VDD=6V, IDD=1100mA(@Tc=+25deg.C), Pout=18dBm/tone

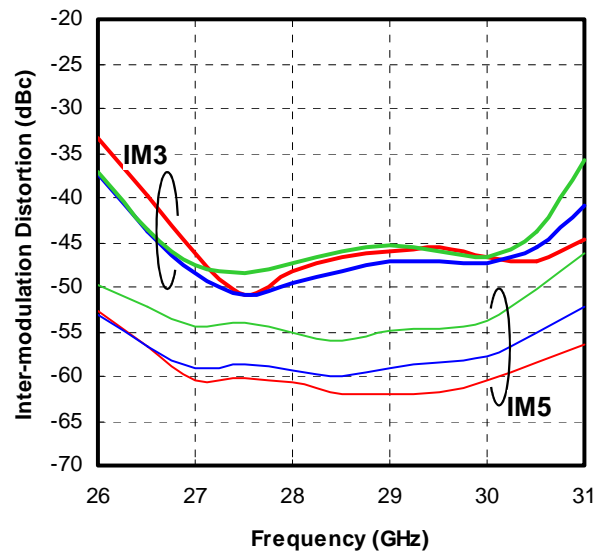

— Tc=-40deg.C — +25deg.C — +85deg.C

■ S-PARAMETERS

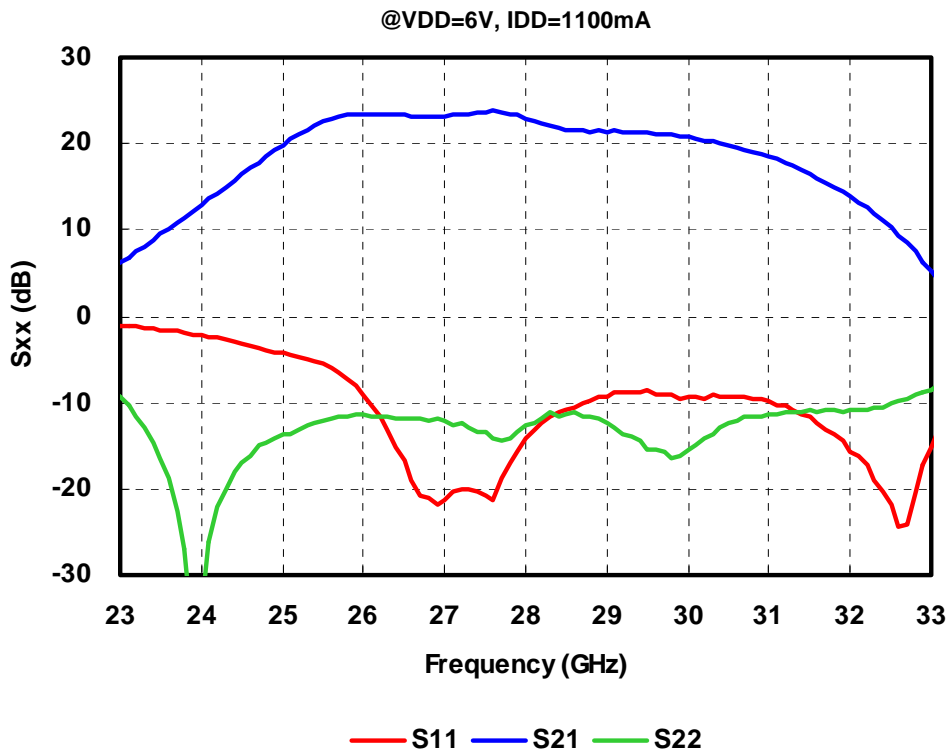
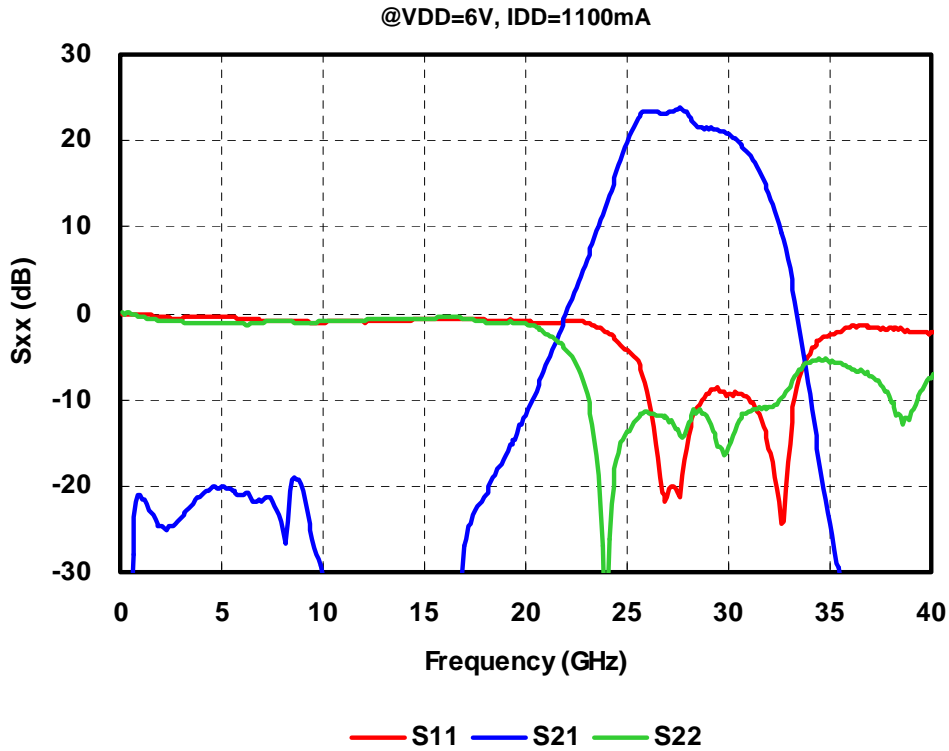

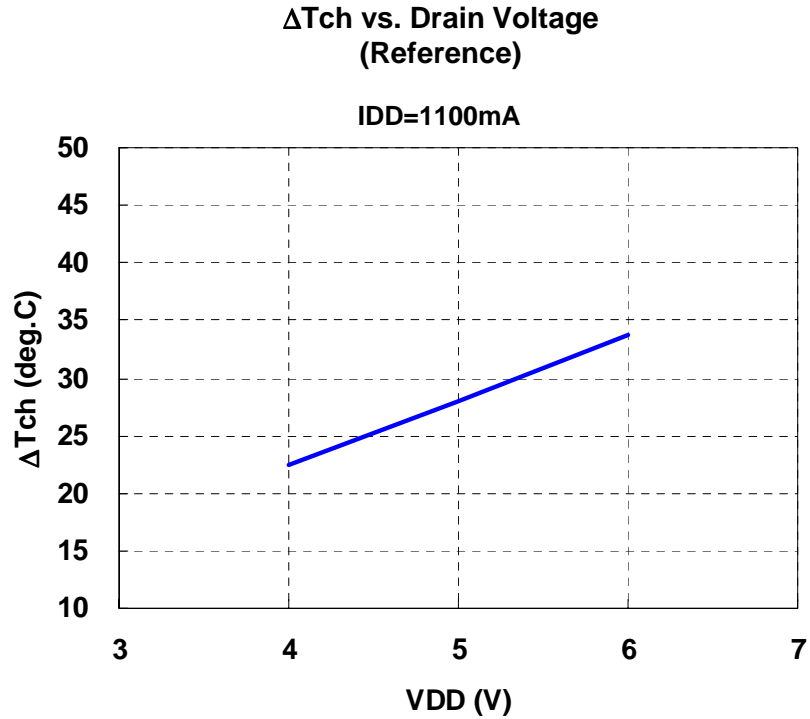

Note: ΔTch : Temperature Rise from Backside of the Package to Channel.

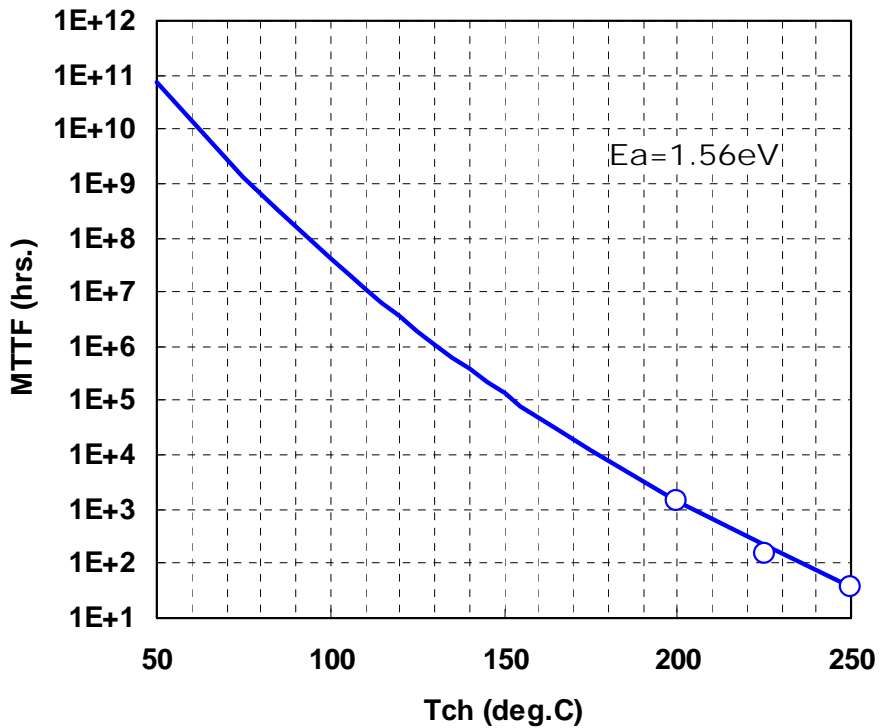

Package Outline and Pin Assignment

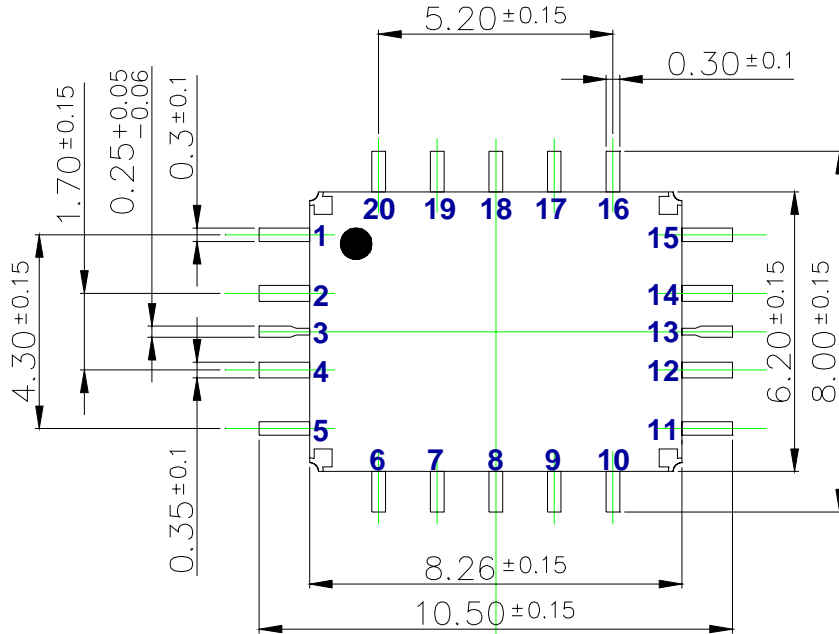

PIN Assignment

- VGG : 1, 5
- VDD : 7, 8, 9, 17, 18, 19
- RF IN : 3
- RF OUT : 13
- GND : 2, 4, 6, 10, 12, 14, 16, 20
- N.C. : 11, 15

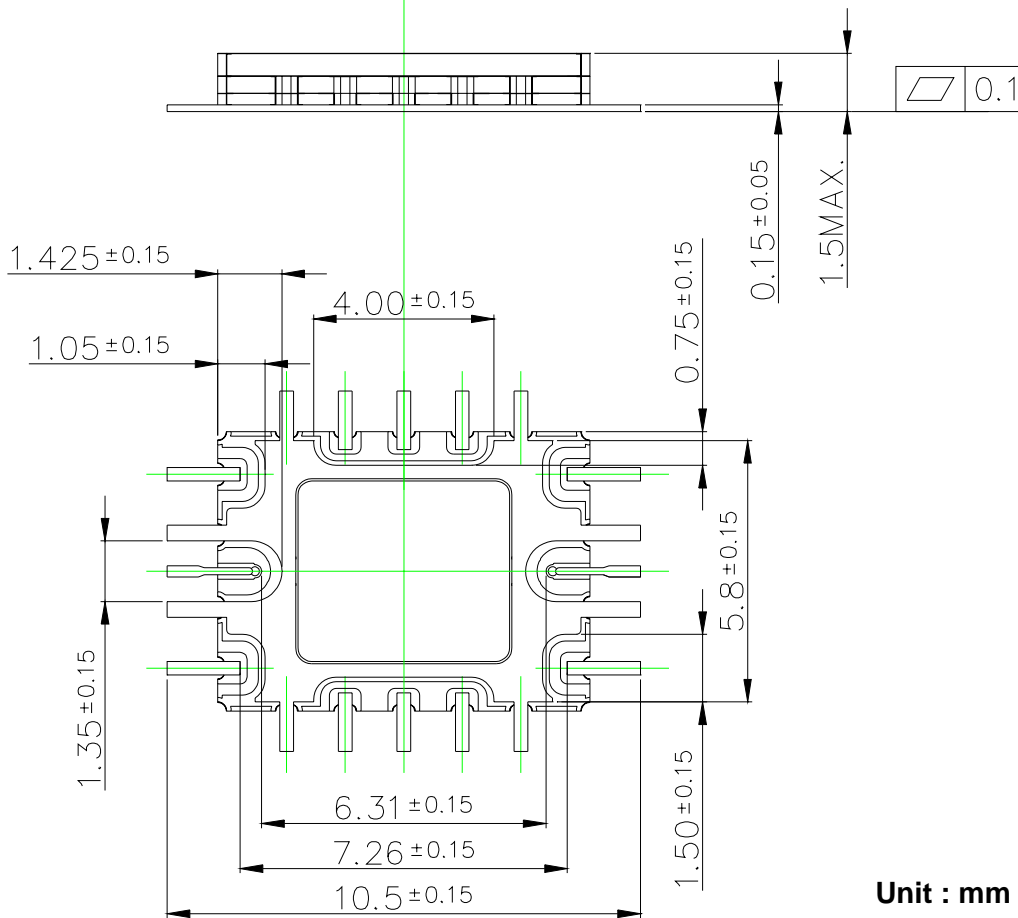

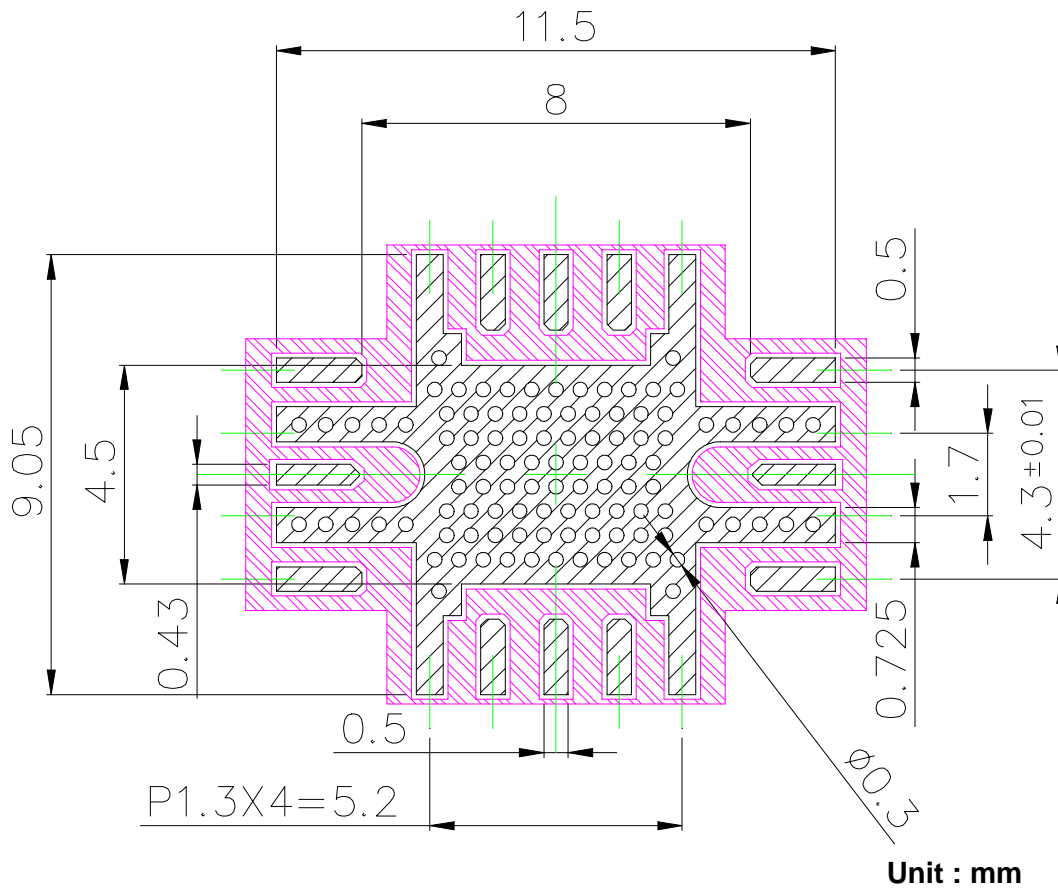

Unit : mm

■PCB Pads and Solder-resist Pattern



NOTES.

1. CORE MATERIAL: Rogers CORP. R04003
 THICKNESS 0.2mm typ., Er=3.38 typ.
2. COPPER FOIL THICKNESS 18um typ.
3.  : FINISH COPPER FOIL: Ni 1um Min./Au 0.1um max.
4.  : RESIST

Block Diagram

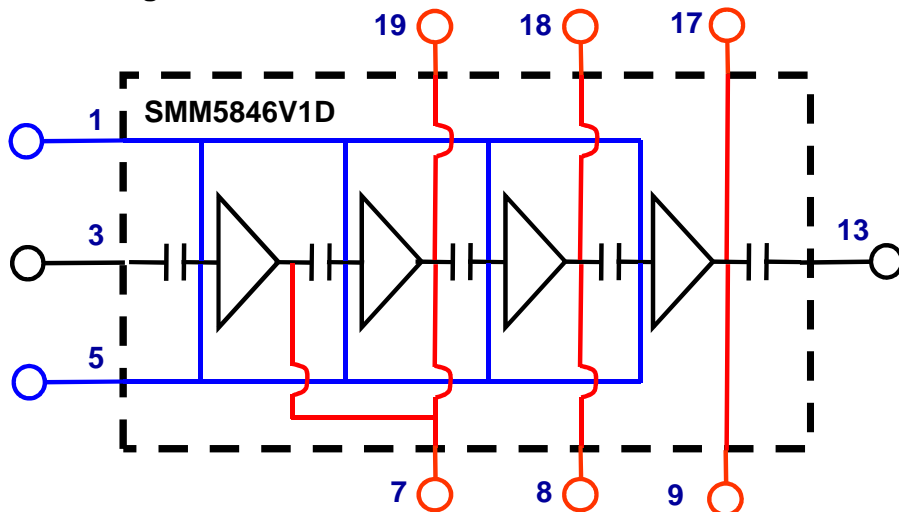

PIN Assignment

- VGG : 1, 5
- VDD : 7, 8, 9, 17, 18, 19
- RF IN : 3
- RF OUT : 13
- GND : 2, 4, 6, 10, 12, 14, 16, 20
- N.C. : 11, 15

Recommended Bias Network

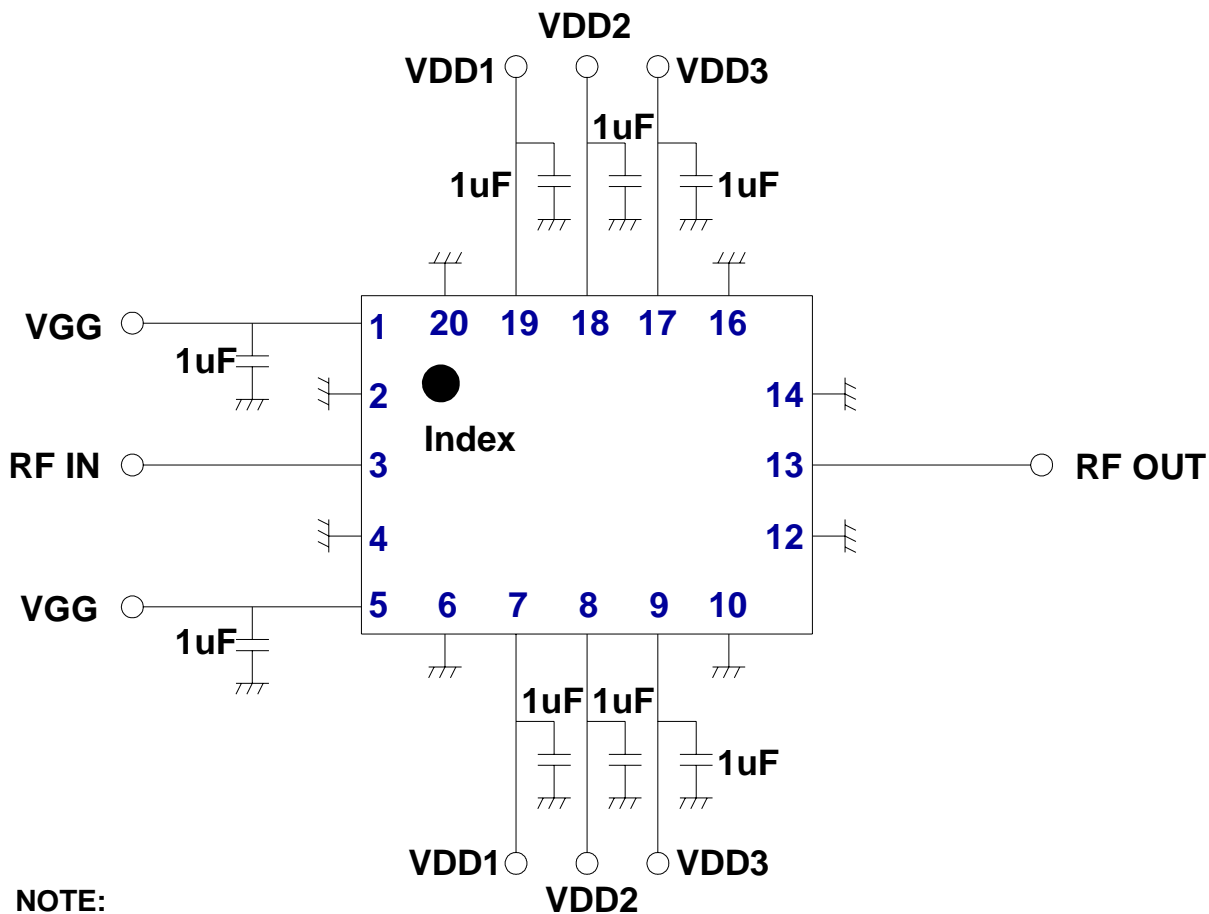

NOTE:

1. The capacitors are recommended on each bias supply lines, close to the package, in order to prevent video oscillations which could damage the module.
2. Two pins named VGG are internally connected.
3. The same pins named VDD are also internally connected.

■4-inch Tray Packing (Part No. : SMM5846V1D)

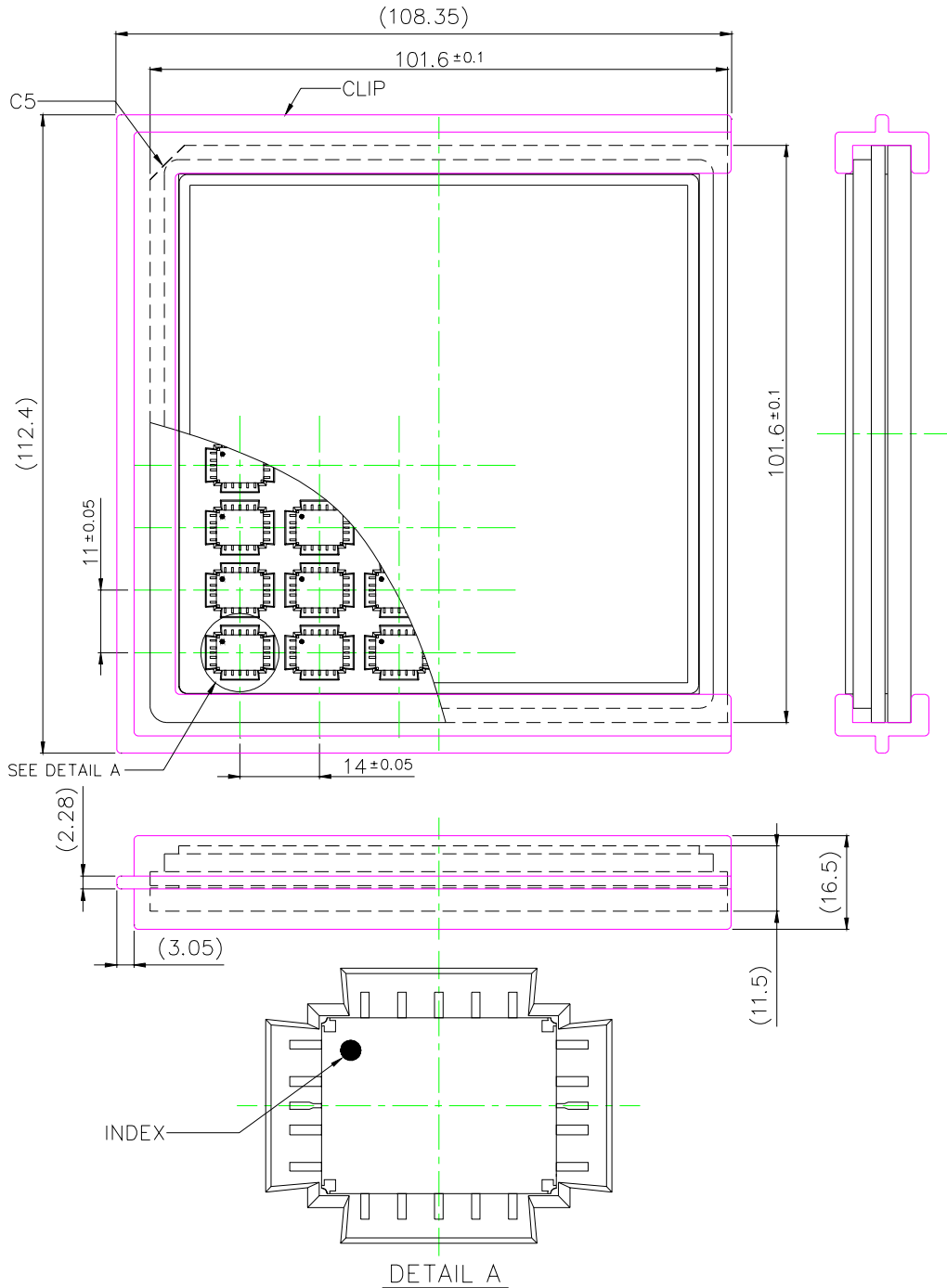

- (1) Maximum Quantity : 48 pcs. / Tray
- (2) Tray Material : Conductive PS

■ Mounting Method of SMD(Surface Mount Devices) for Lead-free solder

Mounting Condition

- (1) For soldering, Lead-free solder (Sn-3.0Ag-0.5Cu)*1 or equivalent shall be used.
(*1: The figure displays with weight %. A predominantly tin-rich alloy with 3.0% silver and 0.5% copper.)
- (2) A rosin type flux with a chlorine content of 0.2% or less shall be used. The rosin flux with low halogen content is recommended.
- (3) When soldering, use one of the following time / temperature methods for acceptable solder joints. Make sure the devices have been properly prepared with flux prior soldering.

* Reflow soldering method (Infrared reflow / Heat circulation reflow / Hot plate reflow):

Limit solder to 3 reflow cycles because resin is used in the modules manufacturing process. Excessive reflow cycles will effect the resin resulting in a potential failure or latent defect. The recommended reflow temperature profile is shown below. The temperature of the reflow profile must be measured at the device body surface.

Reflow temperature profile and condition:

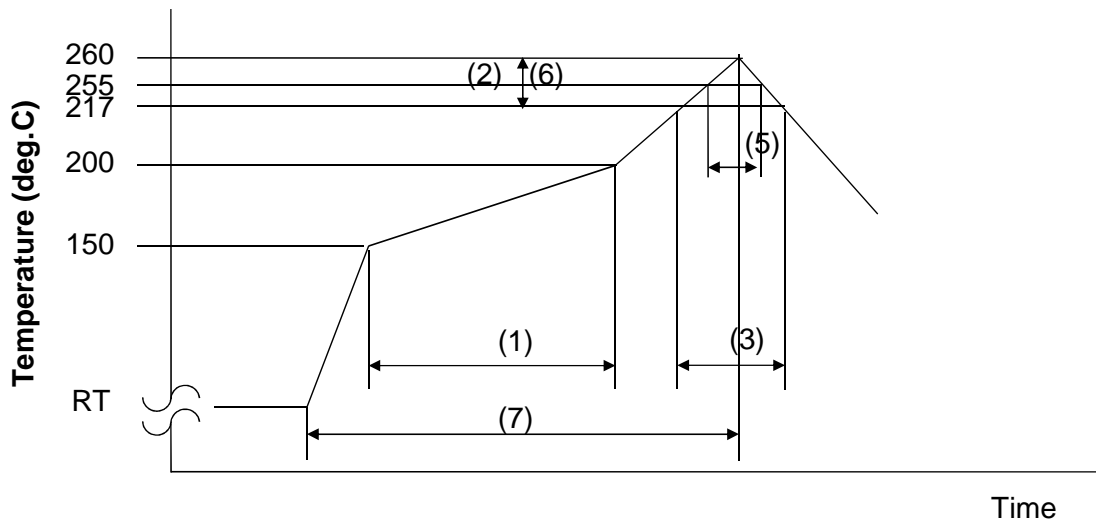

- | | |
|---|-------------------------------------|
| (1) Preheating: | 150 to 200 deg.C, 60 to 120 seconds |
| (2) Ramp-up Rate: | 3 deg.C /seconds max |
| (3) Liquidous temperature and time: | 217 deg.C, 60 to 150 seconds |
| (4) Peak Temperature: | 260 deg.C |
| (5) Time Peak Temperature within 5 deg.C: | under 30seconds |
| (6) Ramp-down Rate: | 6 deg.C /seconds max |
| (7) Time RT to peak temperature: | 8 minutes max |

* Measurement point: Center of the package body surface

- (4) The above-recommended conditions were confirmed using the manufacture's equipment and materials. However, when soldering these products, the soldering condition should be verified by customer using their equipment and materials.

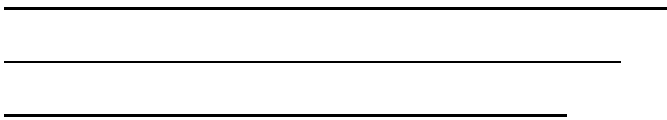

SMM5846V1D

Ka-Band Power Amplifier MMIC

For further information please contact:

<http://global-sei.com/Electro-optic/about/office.html>

CAUTION

This product contains **gallium arsenide (GaAs)** which can be hazardous to the human body and the environment. For safety, observe the following procedures:

- Do not put these products into the mouth.
- Do not alter the form of this product into a gas, powder, or liquid through burning, crushing, or chemical processing as these by-products are dangerous to the human body if inhaled, ingested, or swallowed.
- Observe government laws and company regulations when discarding this product. This product must be discarded in accordance with methods specified by applicable hazardous waste procedures.