



SMM5722XZ

12 – 16GHz Low Noise/ Driver Amplifier MMIC

FEATURES

- Wafer Level Chip Size Package with Solder Ball
- Low Noise Figure : NF=2.3dB (typ.)
- High Associated Gain : Gas=20dB (typ.)
- +5dBm Input Third Order Intercept Point (IIP3)
- Low Current Consumption : I_{DD_LNA}=30mA
- Impedance Matched Z_{in}/ Z_{out} = 50ohm

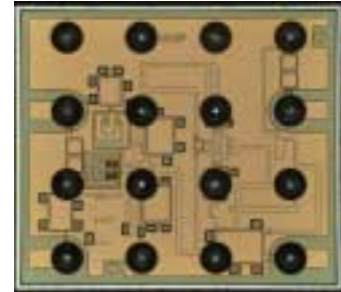

DESCRIPTION

The SMM5722XZ is a Low Noise/ Driver Amp MMIC for applications in the 12 to 16GHz frequency range. This product is well suited for satellite communications, radio link and wireless communications where low noise characteristics is required. The flip chip die can be used in solder reflow process.

Sumitomo Electric Device Innovations's stringent Quality Assurance Program assures the highest reliability and consistent performance.

ABSOLUTE MAXIMUM RATING

Item	Symbol	Rating	Unit
Drain Voltage	V _{DD}	6	V
Gate Voltage (for Gain Control)	V _{GC}	-1	V
Input RF Power	P _{in}	0	dBm
Storage Temperature	T _{stg}	-40 to +125	deg.C

RECOMMENDED OPERATING CONDITIONS

Item	Symbol	Conditions	Unit
Drain Voltage	V _{DD}	5	V
Gate Voltage (for Gain Control)	V _{GC}	-0.5 to 0	V
Input RF Power	P _{in}	<= 0	dBm
Operating Case Temperature	T _c	-40 to +85	deg.C

ELECTRICAL CHARACTERISTICS (Case Temperature T_c=25deg.C)

Item	Symbol	Test Conditions	Limits			Unit
			Min.	Typ.	Max.	
RF Frequency Range	f _{RF}	V _{DD} =5V	12		16	GHz
Associated Gain	Gas	I _{DD_LNA} =30mA *1	17	20	23	dB
Gain Control Range	ΔGain		---	8	---	dB
Noise Figure	NF		---	2.3	3.0	dB
Input 3rd.Order Intercept Point	IIP3		---	5	---	dBm
Output Power at 1dB G.C.P.	P1dB		---	11	---	dBm
Input Return Loss	RLin		---	8	---	dB
Output Return Loss	RLout		---	10	---	dB
V _{GC} Volatge	V _{GC}		-0.5	---	0.0	V

*1. Adjust V_{GC} voltage between 0 to -0.5V to set to I_{DD_LNA}=30mA

ESD	Class 0	up to 250V
------------	---------	------------

Note: Based on JEDEC JESD22-A114-C

RoHS Compliance	Yes
------------------------	-----

ORDERING INFORMATION

Part Number	Order Unit	Packing
SMM5139XZ	100 pcs.	100pcs. / Tray = 100pcs. / Packing
SMM5139ZXT	500 pcs.	500pcs. / Reel = 500pcs. / Packing



SMM5722XZ

12 – 16GHz Low Noise/ Driver Amplifier MMIC

CONVERSION GAIN vs. RF FREQUENCY

@ $V_{DD}=5V$, $I_{DD}=30mA$, $T_c=+25deg.c$, $P_{in}=-20dBm$

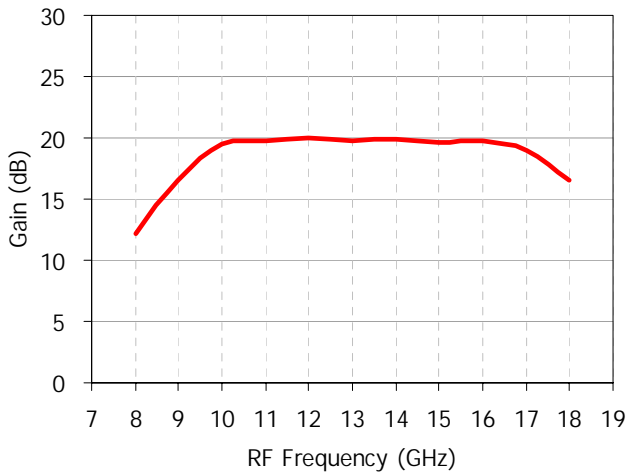

INPUT IP3 vs. RF FREQUENCY

@ $V_{DD}=5V$, $I_{DD}=30mA$, $T_c=+25deg.c$, $P_{in}=-17dBm$ (2-tone)

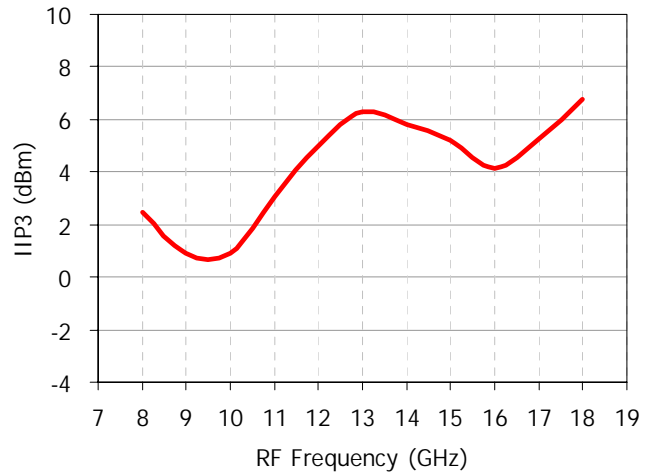

NOISE FIGURE vs. RF FREQUENCY

@ $V_{DD}=5V$, $I_{DD}=30mA$, $T_c=+25deg.c$

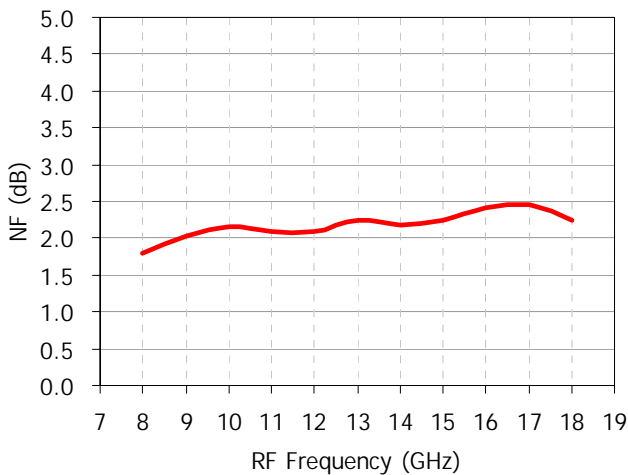

OUTPUT IP3 vs. RF FREQUENCY

@ $V_{DD}=5V$, $I_{DD}=30mA$, $T_c=+25deg.c$, $P_{in}=-17dBm$ (2-tone)

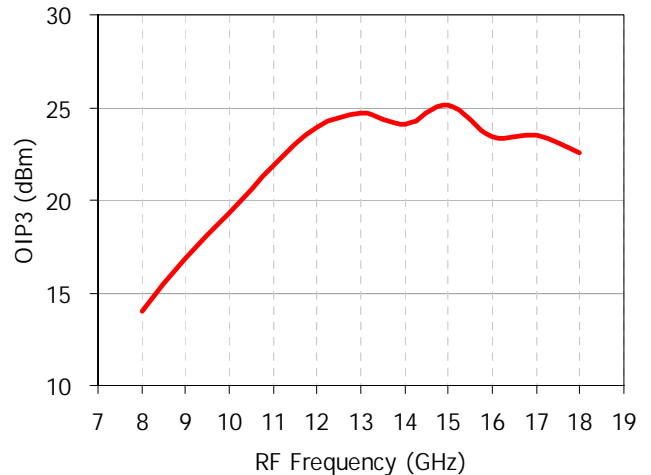



SMM5722XZ

12 – 16GHz Low Noise/ Driver Amplifier MMIC

INPUT RETURN LOSS

@ $V_{DD}=5V$, $I_{DD}=30mA$, $T_C=+25deg.c$

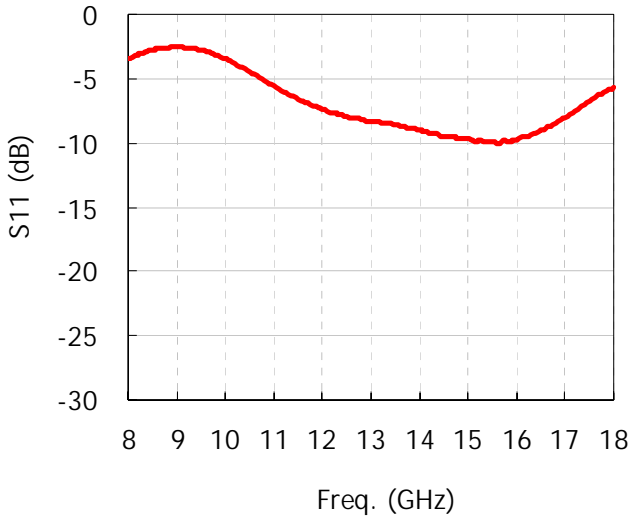

OUTPUT RETURN LOSS

@ $V_{DD}=5V$, $I_{DD}=30mA$, $T_C=+25deg.c$

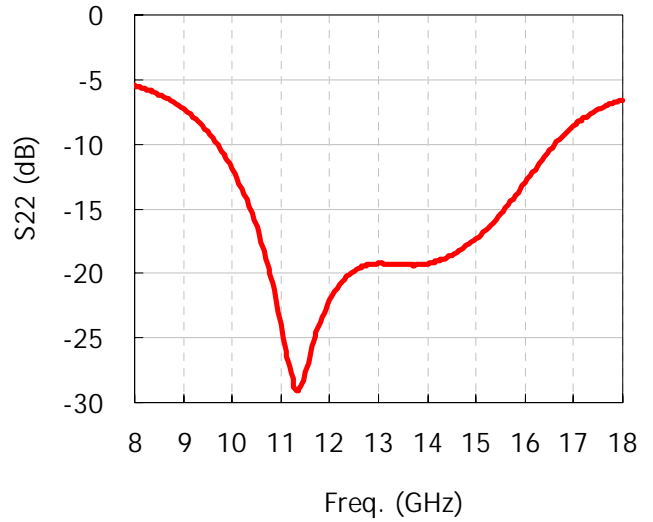

FORWARD TRANSMISSION

@ $V_{DD}=5V$, $I_{DD}=30mA$, $T_C=+25deg.c$

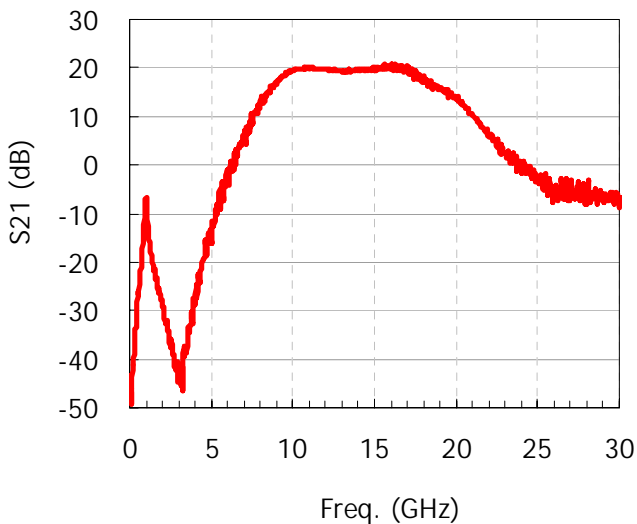



SMM5722XZ

12 – 16GHz Low Noise/ Driver Amplifier MMIC

CONVERSION GAIN vs. IDD

@ $V_{DD}=5V$, $T_c=+25^{\circ}C$, $P_{in}=-20dBm$

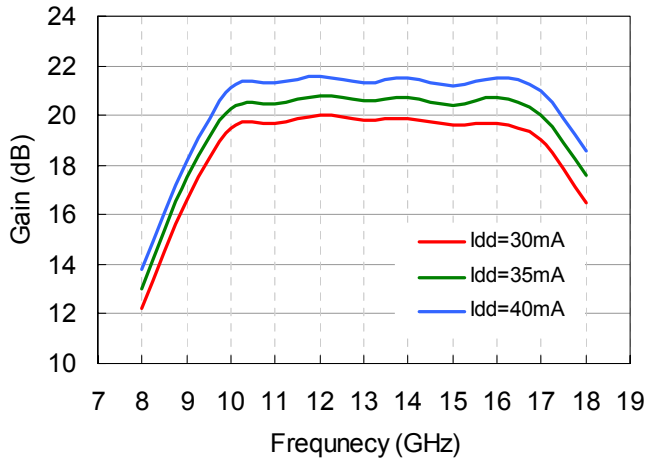

INPUT IP3 vs. IDD

@ $V_{DD}=5V$, $T_c=+25^{\circ}C$, $P_{in}=-17dBm$ (2-tone)

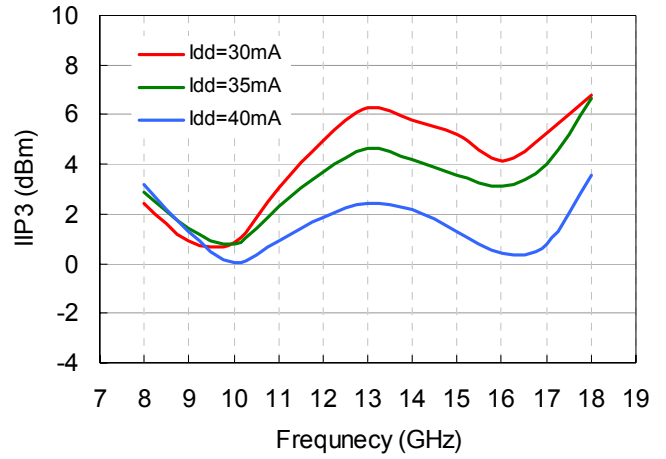

NOISE FIGURE vs. IDD

@ $V_{DD}=5V$, $T_c=+25^{\circ}C$

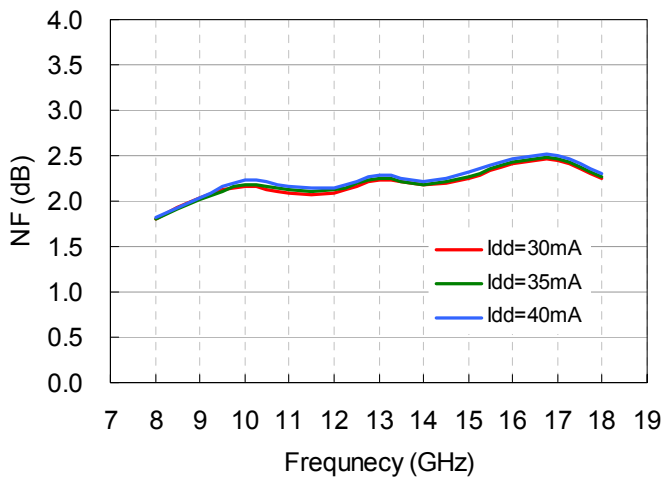



SMM5722XZ

12 – 16GHz Low Noise/ Driver Amplifier MMIC

Pout vs. RF FREQUENCY

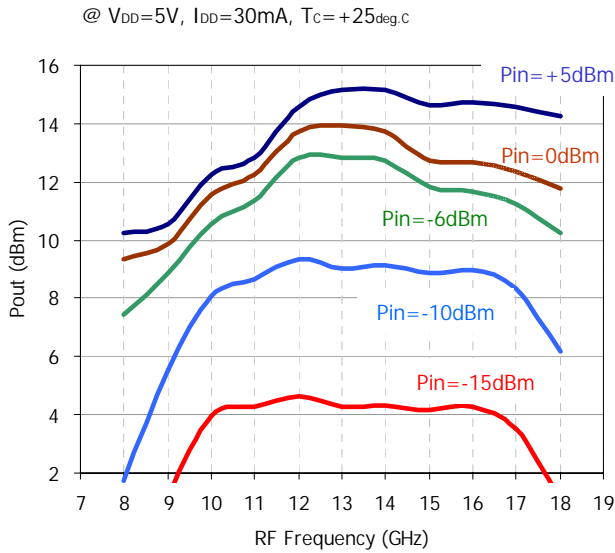

INPUT IP3 vs. PIN

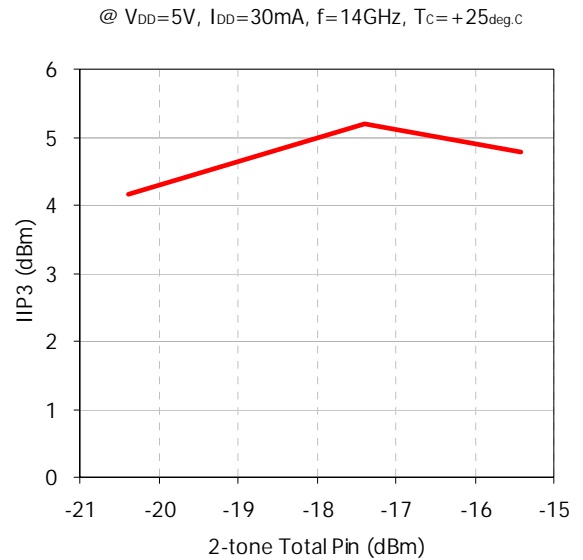

POUT, IDD vs. PIN

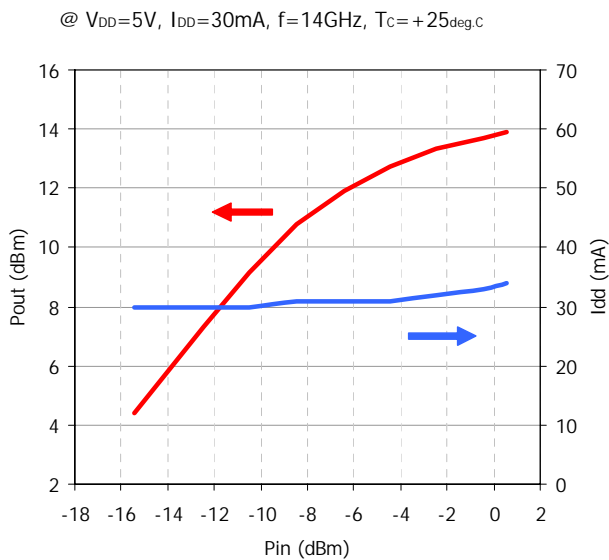

OUTPUT IP3 vs. PIN

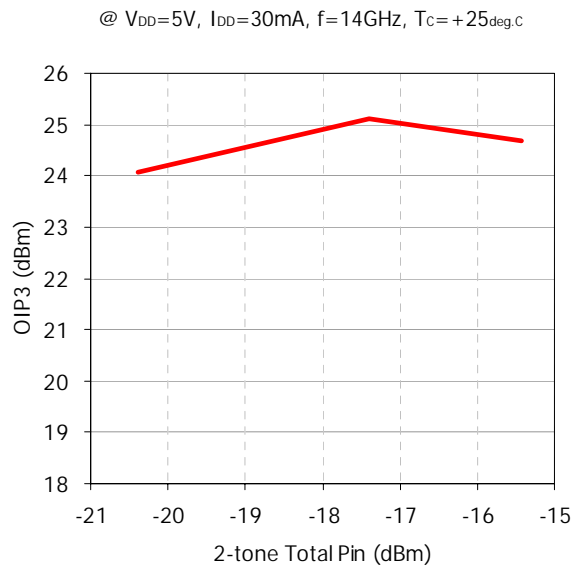



SMM5722XZ

12 – 16GHz Low Noise/ Driver Amplifier MMIC

CONVERSION GAIN vs. VGC

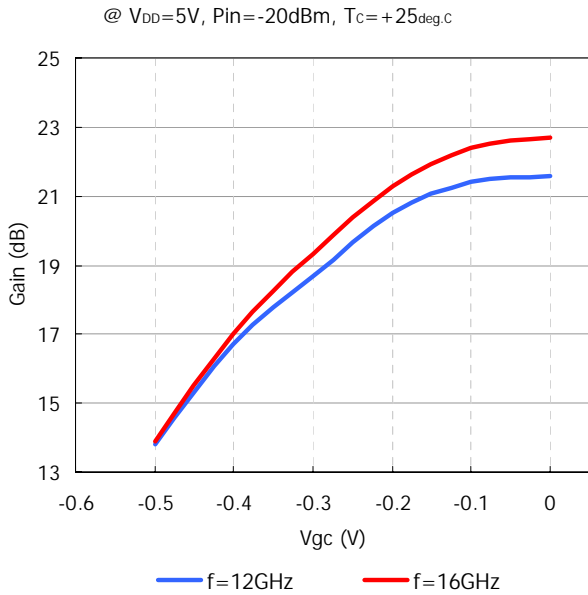

Current consumption vs. VGC

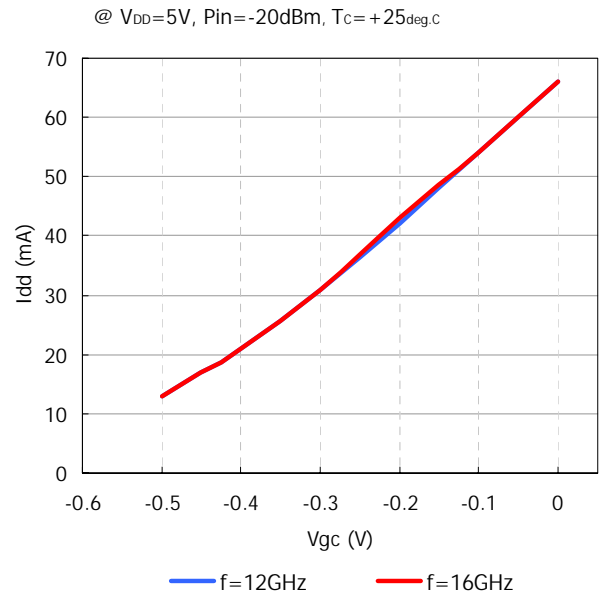

INPUT IP3 vs. VGC

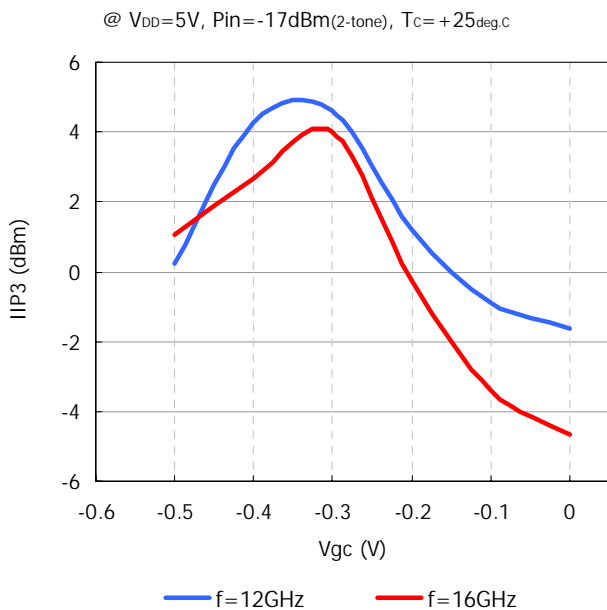

OUTPUT IP3 vs. VGC

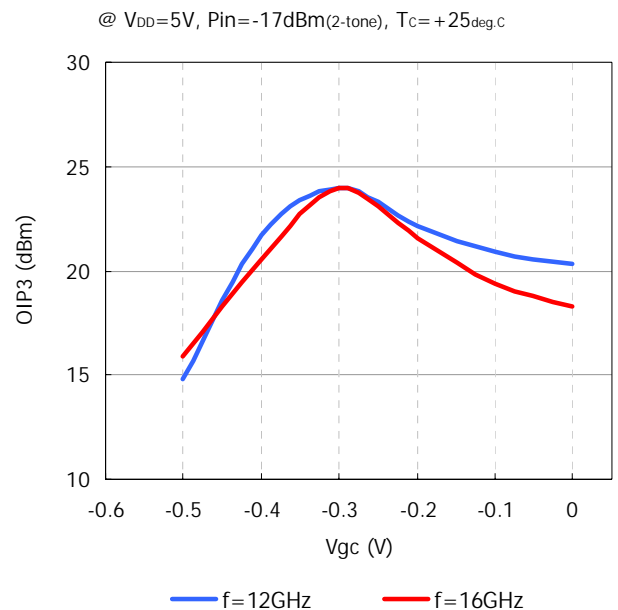



SMM5722XZ

12 – 16GHz Low Noise/ Driver Amplifier MMIC

CONVERSION GAIN vs. TEMPERATURE

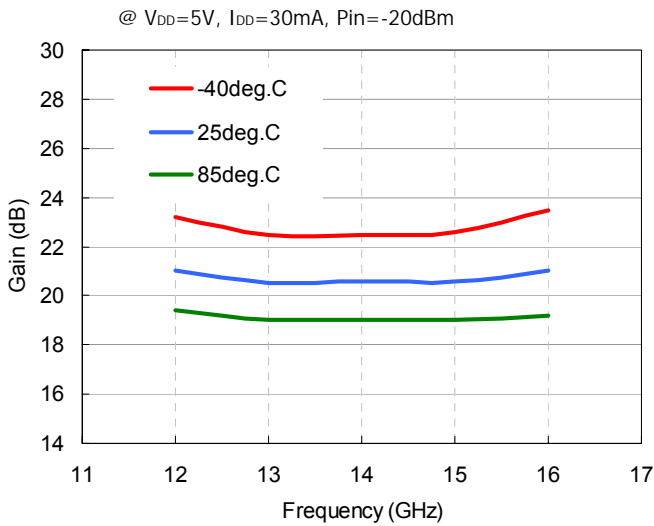

INPUT IP3 vs. TEMPERATURE

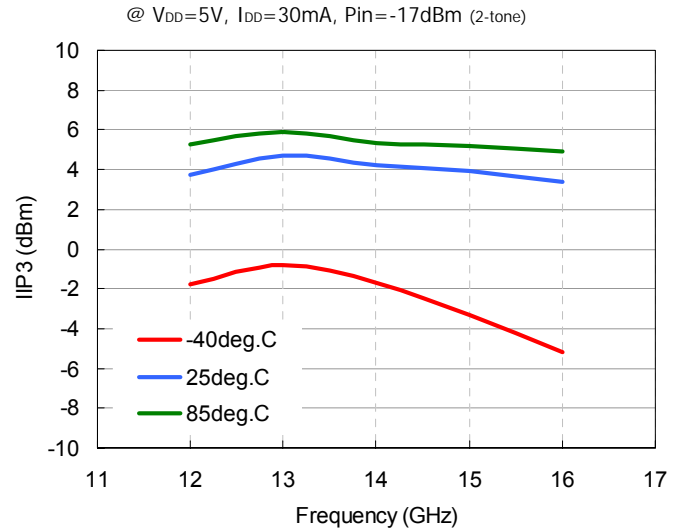

OUTPUT IP3 vs. TEMPERATURE

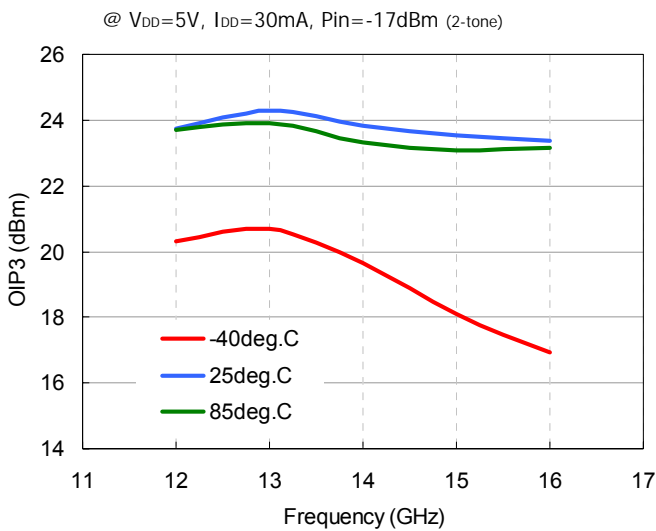



SMM5722XZ

12 – 16GHz Low Noise/ Driver Amplifier MMIC

■ Chip outline and Functional Diagram

Die Size : 1.77mm x 1.57mm
Die Thickness : 275um
Solder ball diameter : 168um
Solder ball thickness : 121um
Pad Pitch : 400um
Alloy of solder ball : Sn-3.0Ag-0.5Cu

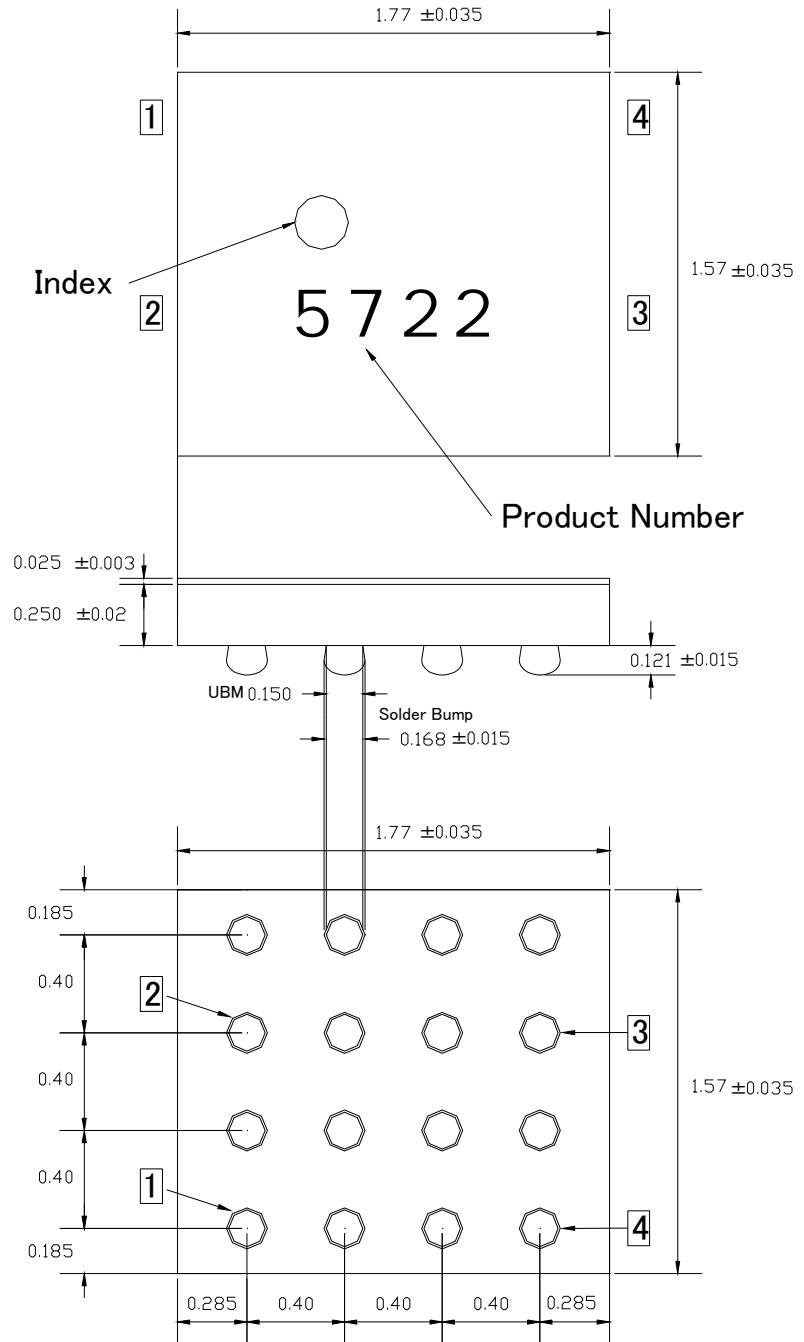

■ Typical Application

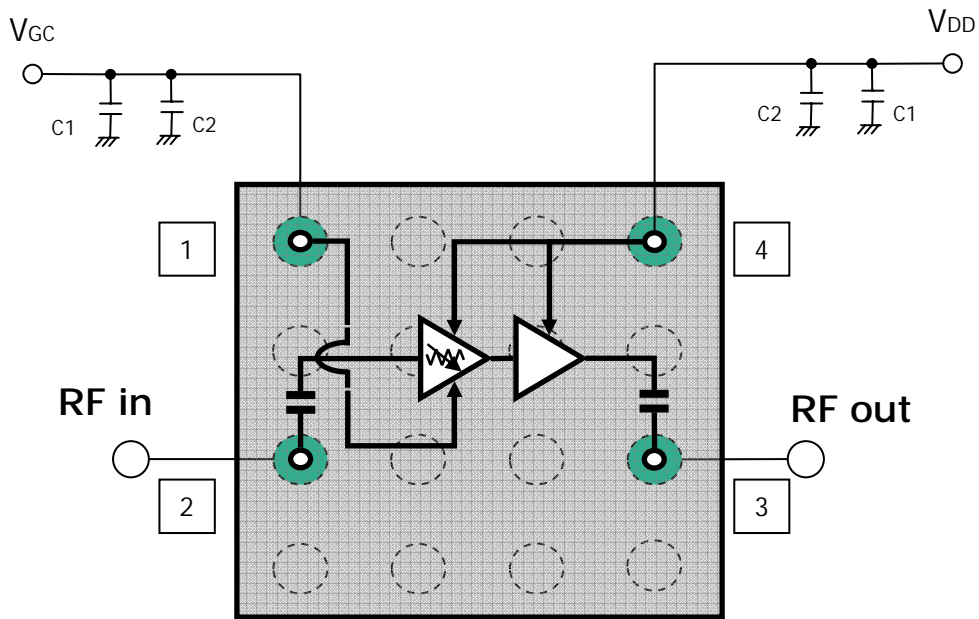

Pin Assignment

Pin	Name
1	VGC
2	RF input
3	RF output
4	VDD

Component List

Name	Description	Value
C1	Capacitor	0.1uF
C2	Capacitor	100pF

*All bumps except Pin 1 to 4 are GND

■ PCB and Solder-resist Pattern

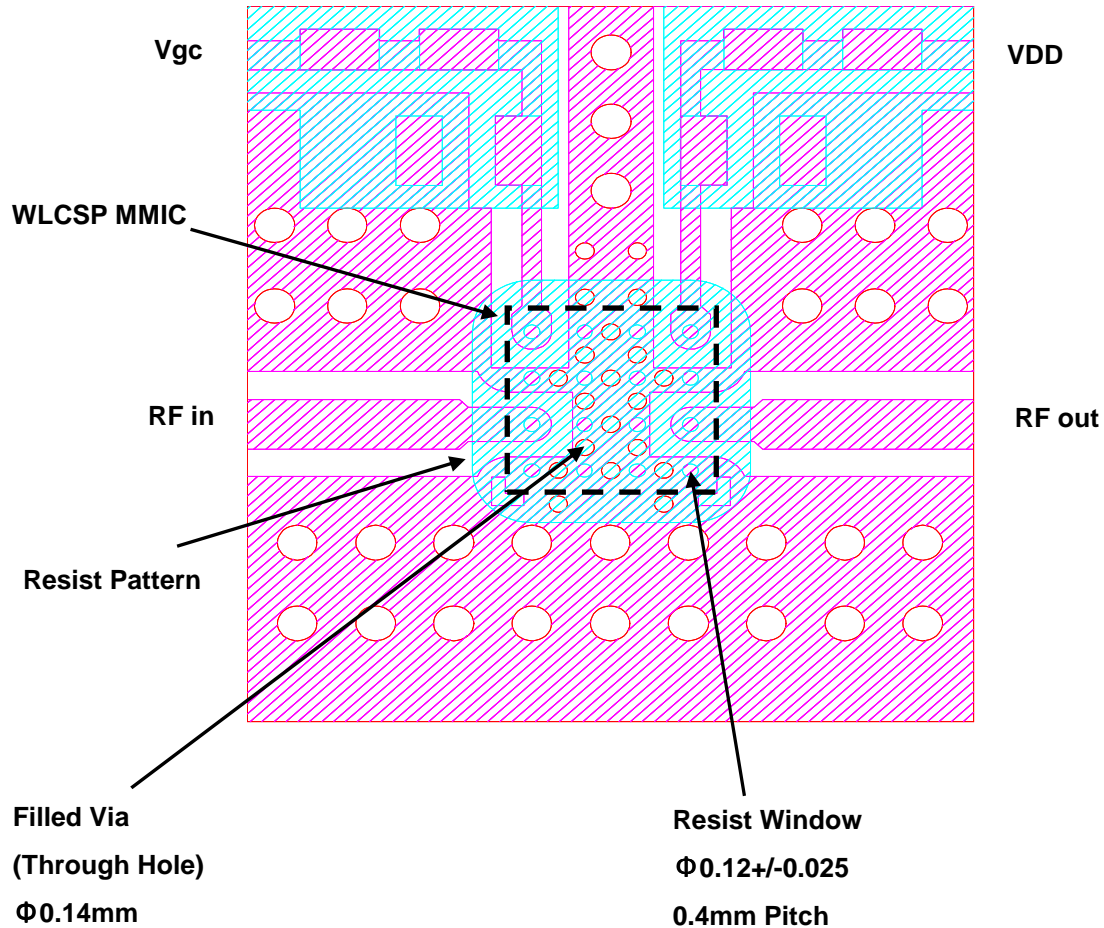

NOTES.

- 1) CORE MATERIAL ; ROGERS CORP. 4003
THICKNESS 0.2MM TYP. , ER=3.38 TYP.
- 2) COPPER FOIL THICKNESS ; 18UM TYP.
- 3) FINISH COPPER FOIL ; NI 1UM MIN. / AU 0.1UM MAX.
- 4) RESIST ; +/- 25UM.
- 5) ALL DIMENSIONS ARE IN MM.



SMM5722XZ

12 – 16GHz Low Noise/ Driver Amplifier MMIC

■ 2-inch Tray Packing (Part No. : SMM5722XZ)

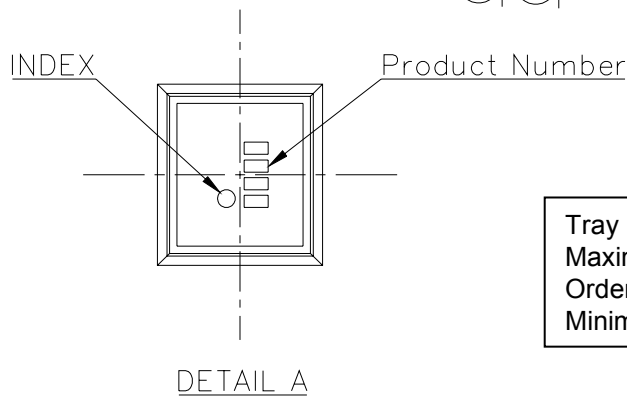
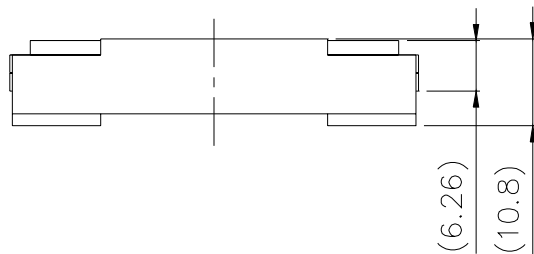
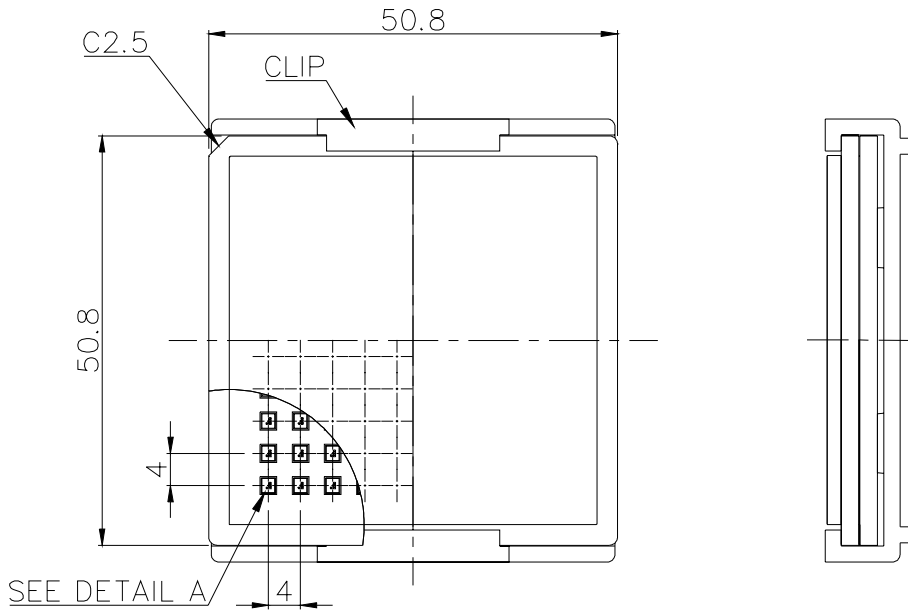

Tray Material : ABS – TP10
Maximum Quantity : 100 pcs. / Tray
Ordering Unit : 100 pcs. / order
Minimum Order ing Unit : 100 pcs. (1 Tray)



SMM5722XZ

12 – 16GHz Low Noise/ Driver Amplifier MMIC

■ Tape and Reel Packing (Part No. : SMM5722XZT)

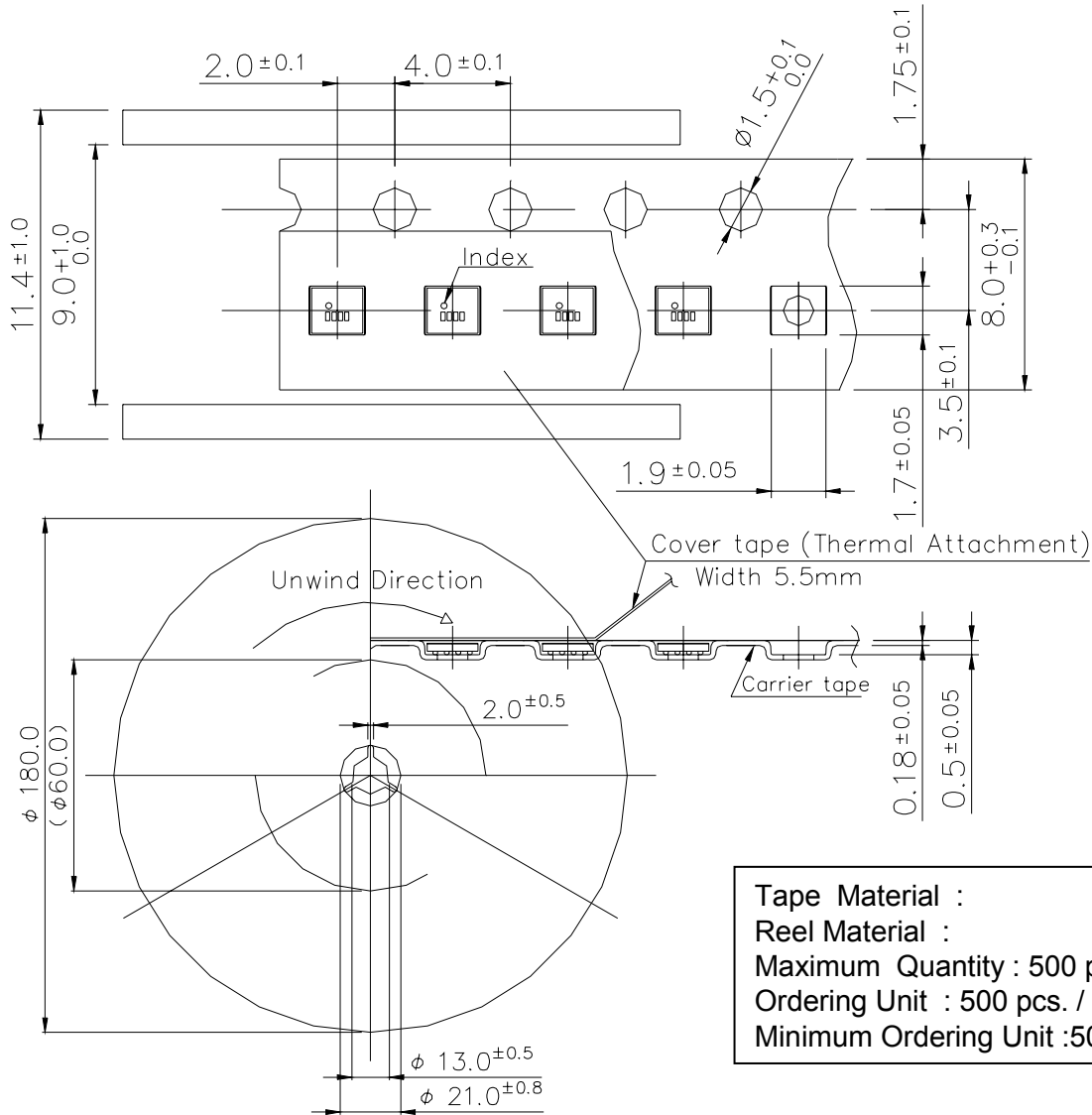

- (1) Quantity 500pcs.
- (2) Tape material Conductive Polycarbonate
- (3) Reel material Conductive Polystyrene



SMM5722XZ

12 – 16GHz Low Noise/ Driver Amplifier MMIC

For further information please contact:

<http://global-sei.com/Electro-optic/about/office.html>

CAUTION

This product contains **gallium arsenide (GaAs)** which can be hazardous to the human body and the environment. For safety, observe the following procedures:

- Do not put these products into the mouth.
- Do not alter the form of this product into a gas, powder, or liquid through burning, crushing, or chemical processing as these by-products are dangerous to the human body if inhaled, ingested, or swallowed.
- Observe government laws and company regulations when discarding this product. This product must be discarded in accordance with methods specified by applicable hazardous waste procedures.