

FEATURES

- High Output Power: Pout=33.0dBm (typ.)
- Linear Gain: GL=25.0dB (typ.)
- Frequency Band: 12.7 to 15.4GHz
- Impedance Matched Zin/Zout=50ohm
- Integrated Power Detector
- Small Hermetic Metal-Ceramic SMT Package(V1B)

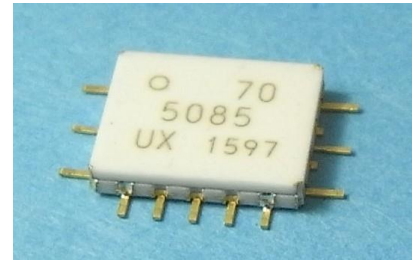

DESCRIPTION

The SMM5085V1B is a MMIC amplifier that contains a three-stages amplifier, internally matched, for standard communications band in the 12.7 to 15.4GHz frequency range.

SEI's stringent Quality Assurance Program assures the highest reliability and consistent performance.

ABSOLUTE MAXIMUM RATING

Item	Symbol	Rating	Unit
DC Positive Supply Voltage	V _{DD}	10	V
DC Negative Supply Voltage	V _{GG}	-3	V
Input Power	P _{in}	+23	dBm
Storage Temperature	T _{stg}	-55 to +125	deg.C

RECOMMENDED OPERATING CONDITIONS

Item	Symbol	Recommend	Unit
DC Positive Supply Voltage	V _{DD}	Up to +6	V
Input Power	P _{in}	Up to +16	dBm
Operating Case Temperature	T _c	-40 to +85	deg.C

ELECTRICAL CHARACTERISTICS (Case Temperature T_c=25deg.C)

Item	Symbol	Test Conditions	Limits			Unit
			Min.	Typ.	Max.	
RF Frequency Range	f	V _{DD} =6.0V	12.7	-	15.4	GHz
Gate Bias Voltage	V _{GG}	I _{DD} (DC)=1200mA typ.	-0.50	-0.1	-0.04	V
Output Power at Pin=13dBm	P _{OUT}	V _{GG} -constant Z _s =Z _i =50ohm	31.5	33.0	-	dBm
Output Power at 1dB G.C.P.	P _{1dB}		-	32.5	-	dBm
Power Gain at 1dB G.C.P.	G _{1dB}		20	24	-	dB
Power-added Efficiency at 1dB G.C.P.	η _{add}		-	20	-	%
Third Order Intermodulation Distortion *	IM3	*:Δf=+10MHz Pout=20.0dBm (S.C.L.)	-38	-44	-	dBc
Drain Current at 1dB G.C.P.	I _{DDRF}		-	1500	1800	mA
Input Return Loss (at Pin=-20dBm)	RL _{IN}		-	8	-	dB
Output Return Loss (at Pin=-20dBm)	RL _{OUT}		-	8	-	dB

G.C.P. : Gain Compression Point
S.C.L. : Single Carrier Level

ESD	Class 0	up to 250V
------------	----------------	-------------------

Note: Based on JEDEC JESD22-A114-C (C=100pF, R=1.5kohm)

CASE STYLE	V1B
RoHS COMPLIANCE	Yes

Ordering Information

Part Number	Order Unit	Packing
SMM5085V1B	No Limitation	48 pcs. / Tray x 4 Trays = 192 pcs. / Packing
SMM5085V1BT	500pcs.	500 pcs. / Reel x 1 Reel = 500 pcs. / Packing

Output Power, Drain Current vs. Input Power

VDD=6V, IDD(DC)=1200mA

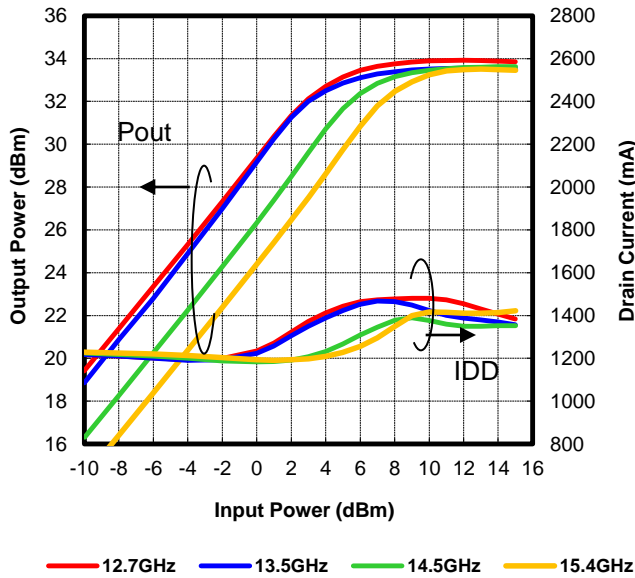

Output Power vs. Frequency

VDD=6V, IDD(DC)=1200mA

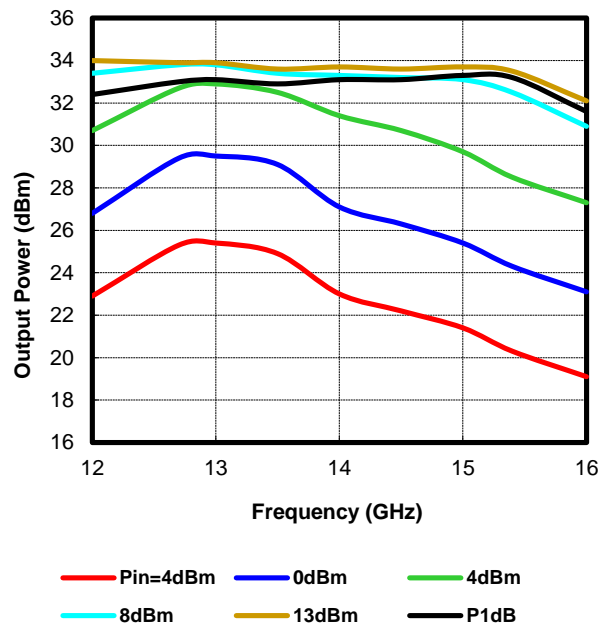

IMD Performance vs. Output Power

VDD=6V, IDD(DC)=1200mA

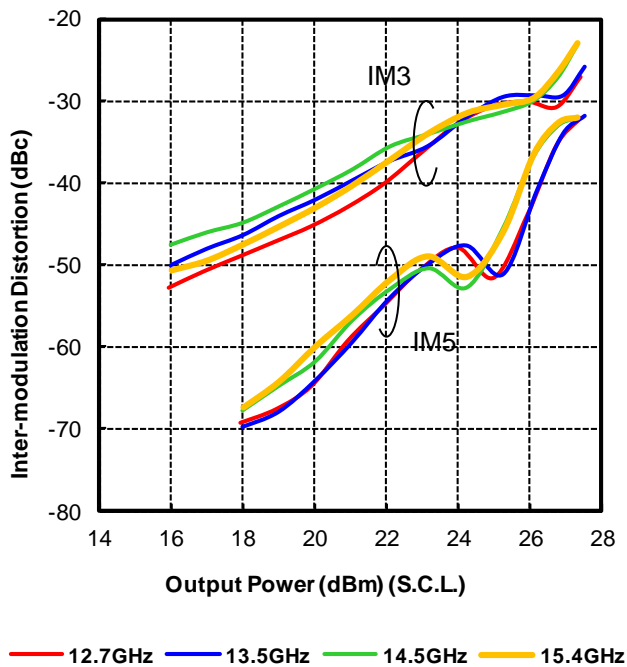

Output Power, Drain Current vs. Input Power by Drain Voltage

IDD(DC)=1200mA, Freq.=12.7GHz

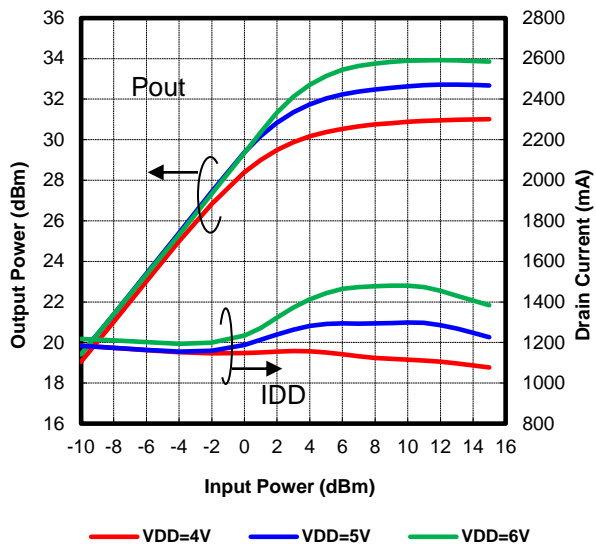

IDD(DC)=1200mA, Freq.=13.5GHz

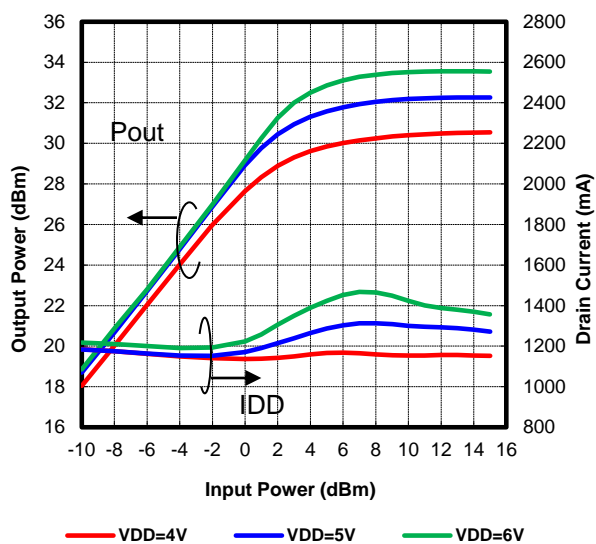

IDD(DC)=1200mA, Freq.=14.5GHz

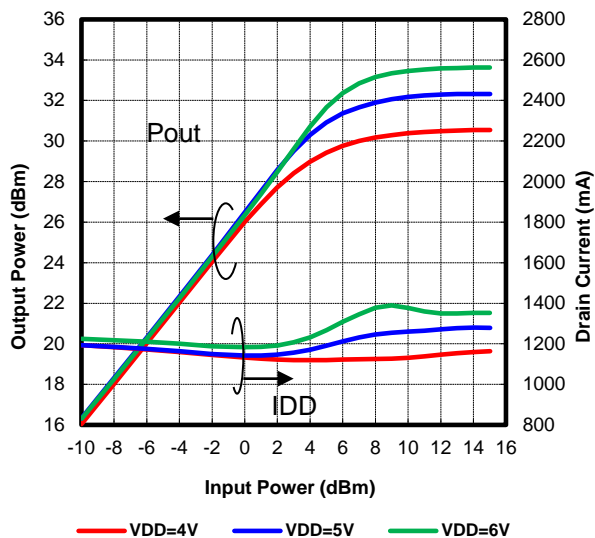

IDD(DC)=1200mA, Freq.=15.4GHz

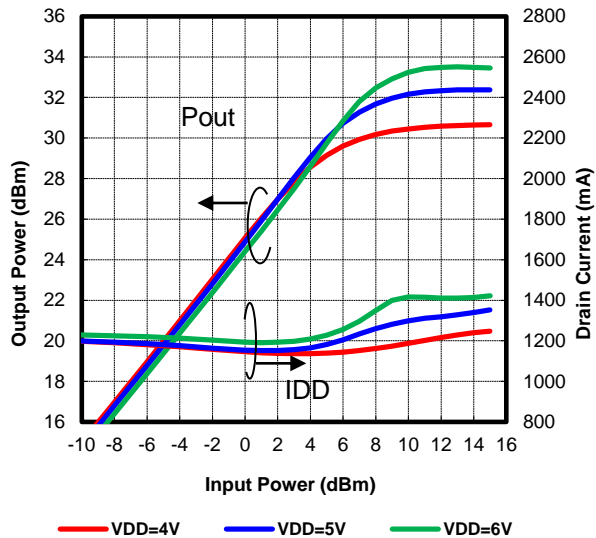

Output Power, Drain Current vs. Input Power by Drain Current

VDD=6V, Freq.=12.7GHz

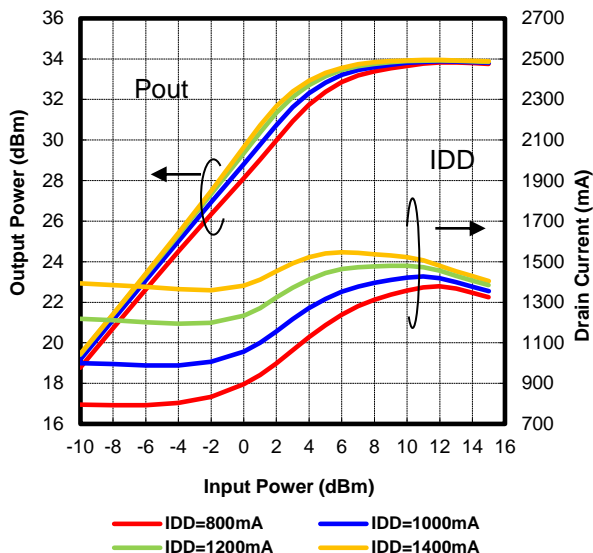

VDD=6V, Freq.=13.5GHz

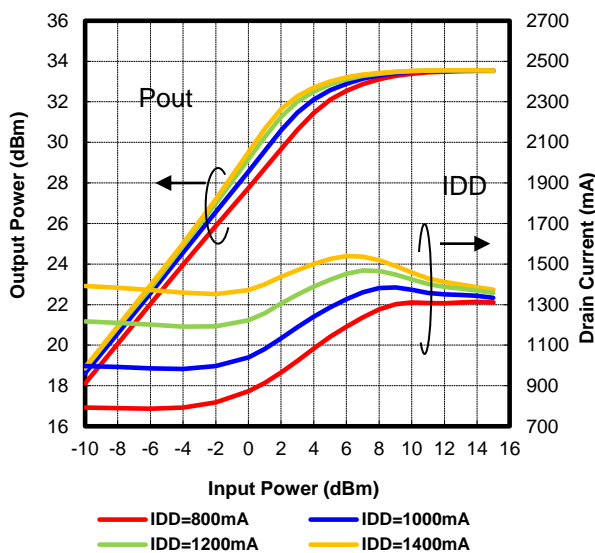

VDD=6V, Freq.=14.5GHz

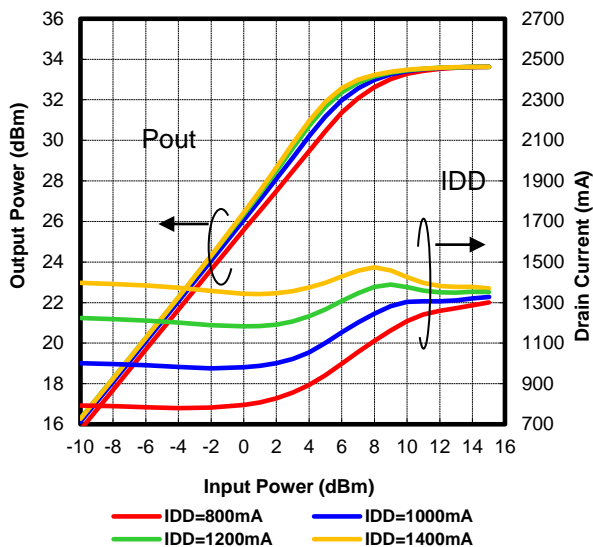

VDD=6V, Freq.=15.4GHz

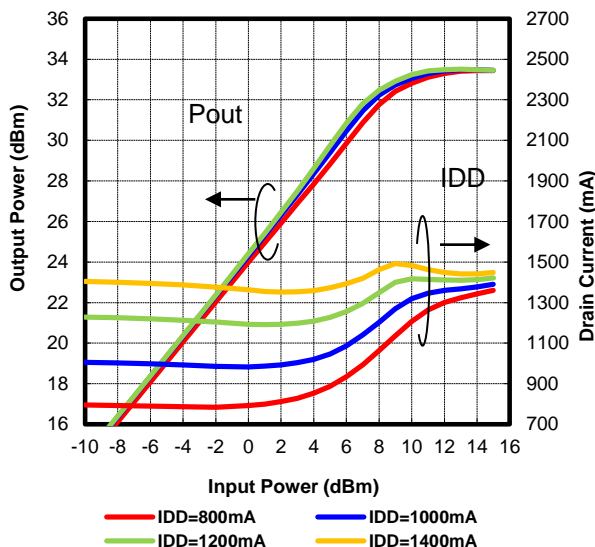

Inter-modulation Distortion vs. Output Power by Drain Voltage

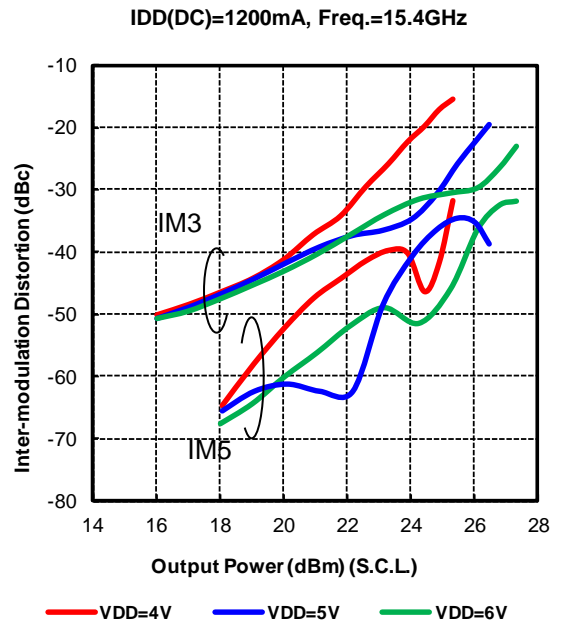
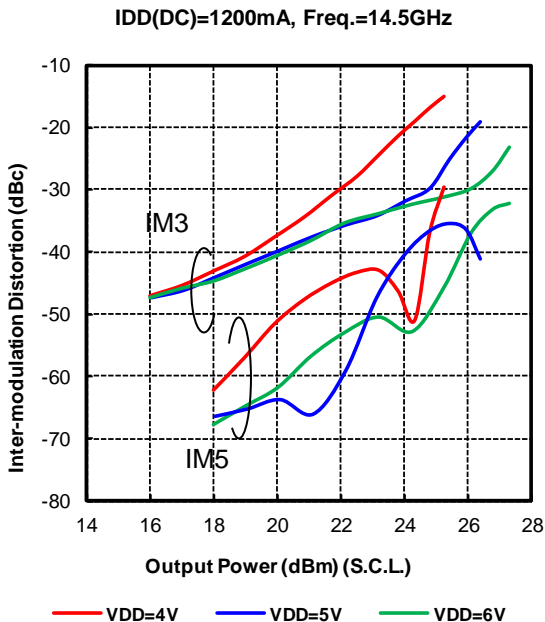
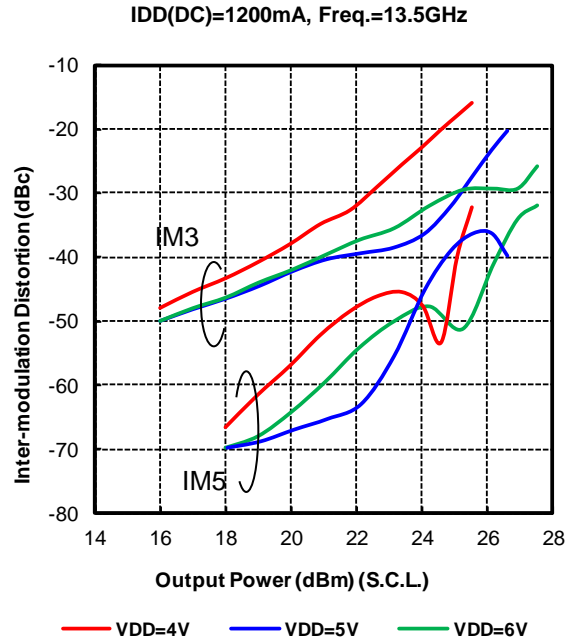
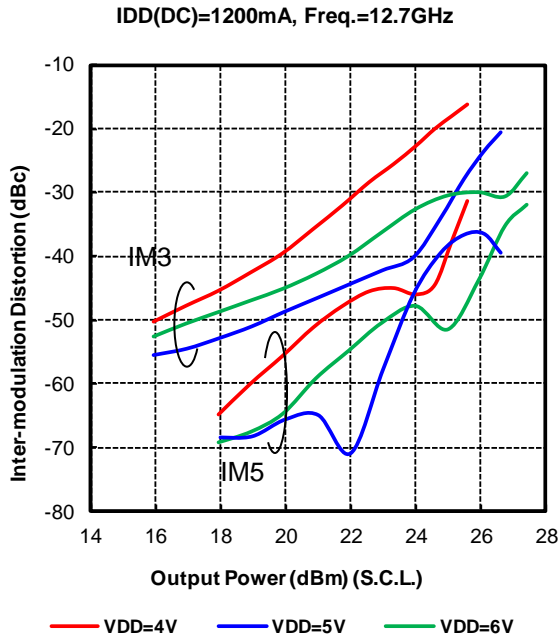

Inter-modulation Distortion vs. Output Power by Drain Current

VDD=6V, Freq.=12.7GHz

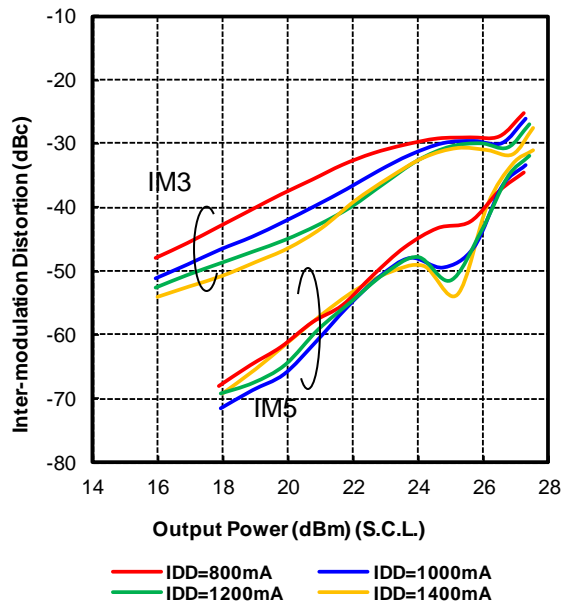

VDD=6V, Freq.=13.5GHz

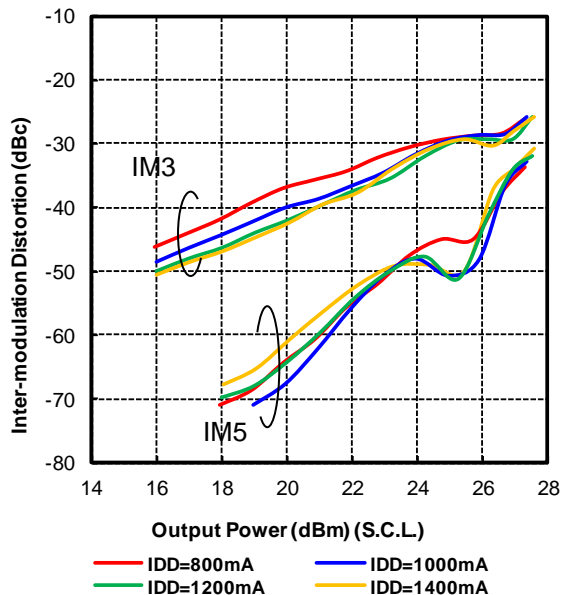

VDD=6V, Freq.=14.5GHz

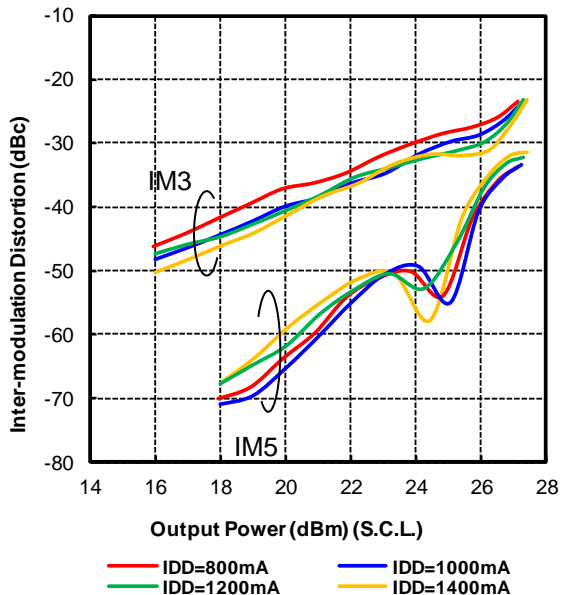

VDD=6V, Freq.=15.4GHz

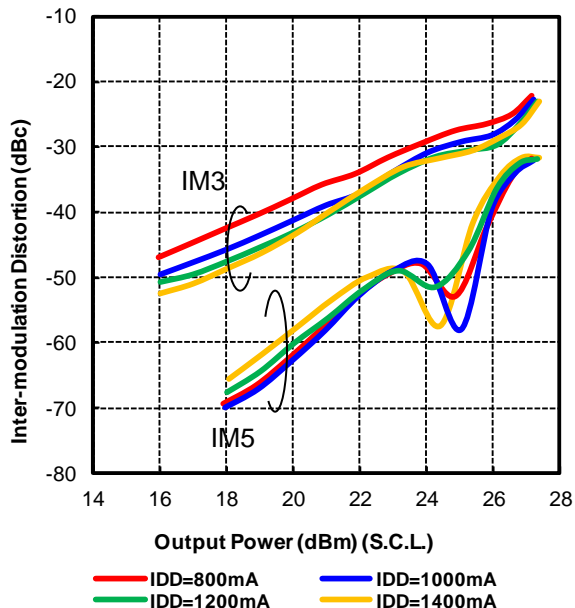

Output Power, Drain Current vs. Input Power by Case Temperature

VDD=6V,IDD(DC)=1200mA(at Tc=25deg.C) , Freq.=12.7GHz

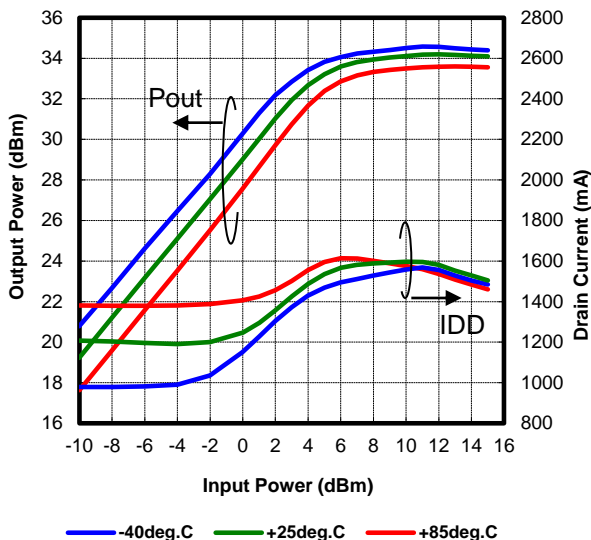

VDD=6V,IDD(DC)=1200mA(at Tc=25deg.C) , Freq.=13.5GHz

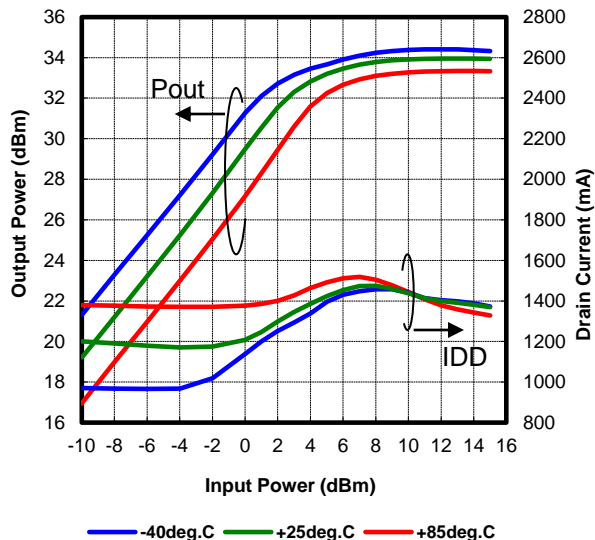

VDD=6V,IDD(DC)=1200mA(at Tc=25deg.C) , Freq.=14.5GHz

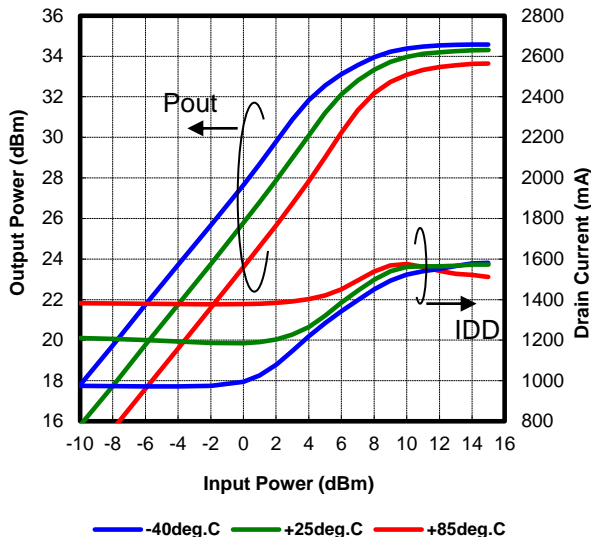

VDD=6V,IDD(DC)=1200mA(at Tc=25deg.C) , Freq.=15.4GHz

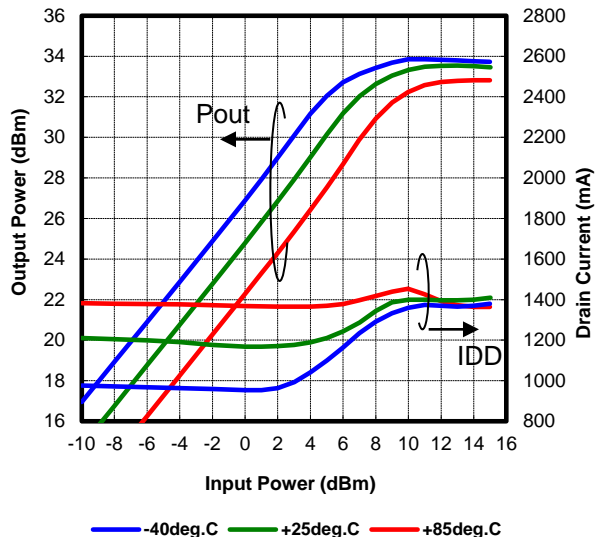

Inter-modulation Distortion vs. Input Power by Case Temperature

VDD=6V,IDD(DC)=1200mA(at Tc=25deg.C) , Freq.=12.7GHz

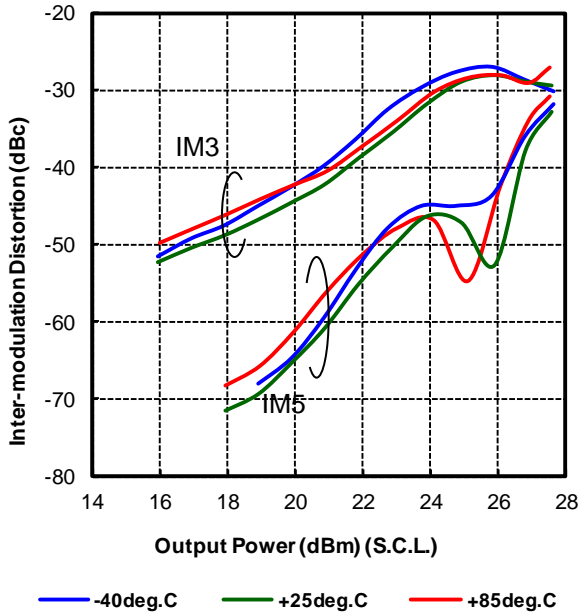

VDD=6V,IDD(DC)=1200mA(at Tc=25deg.C) , Freq.=13.5GHz

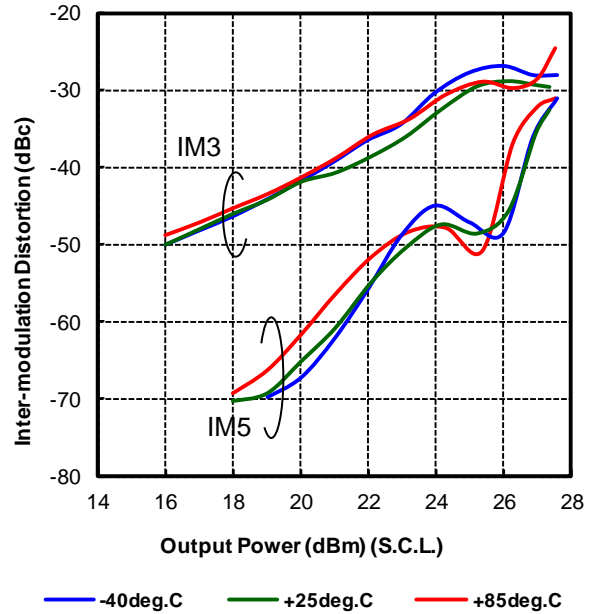

VDD=6V,IDD(DC)=1200mA(at Tc=25deg.C) , Freq.=14.5GHz

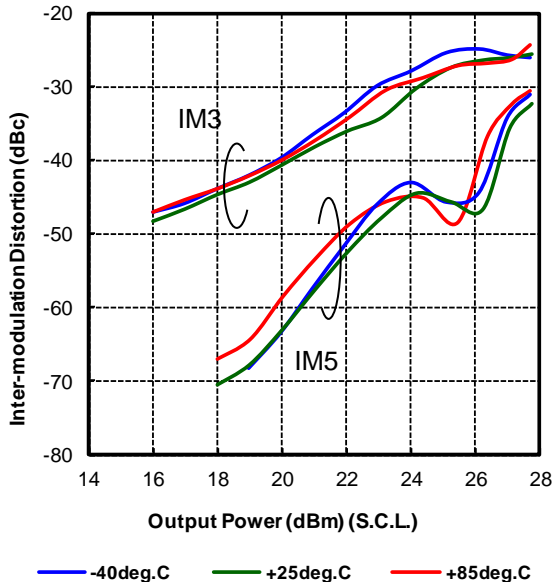

VDD=6V,IDD(DC)=1200mA(at Tc=25deg.C) , Freq.=15.4GHz

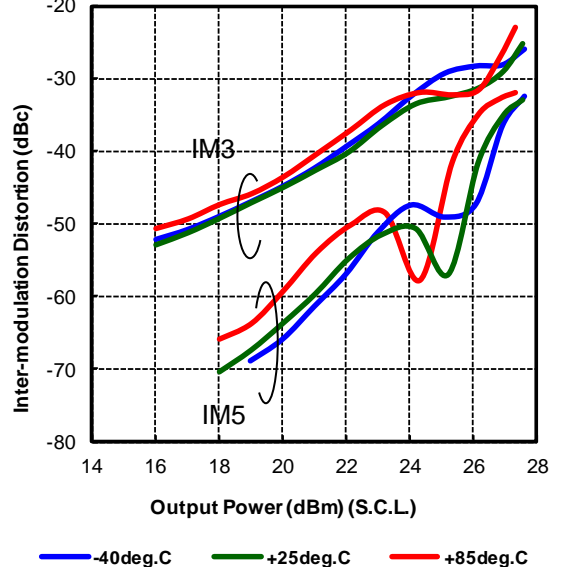

Power Detector vs. Output Power vs. frequency

VDD/IDD(DC)=6V/1200mA, Vdet.Bias=Vref.Bias=5V, Tc=25deg.C

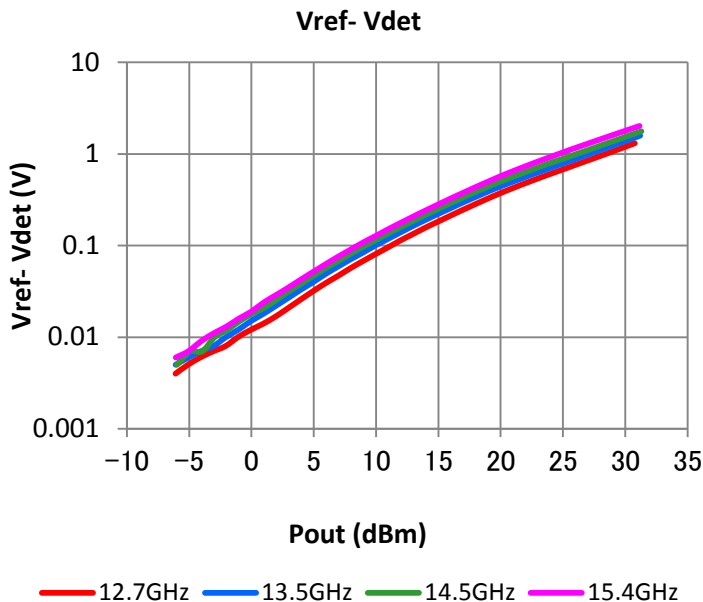
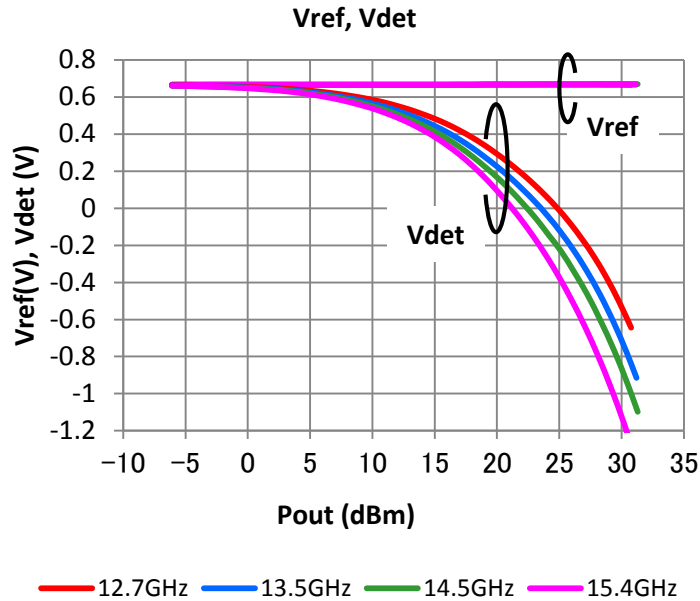

Power Detector vs. Output Power vs. Case Temperature

VDD/IDD(DC)=6V/1200mA, Vdet.Bias=Vref.Bias=5V (at Tc=25deg.C)

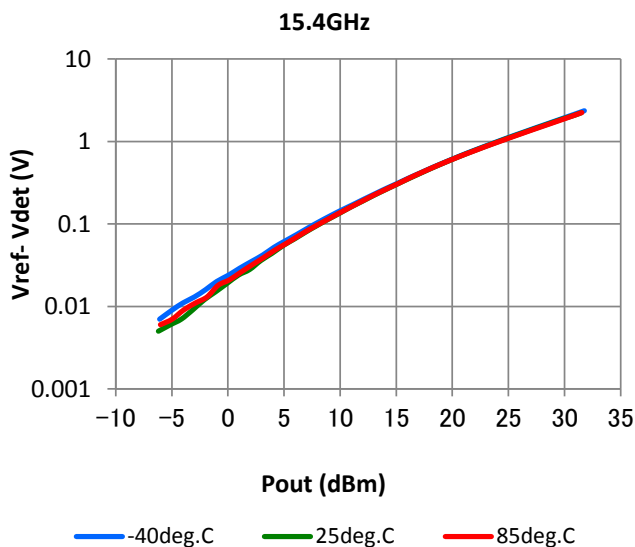
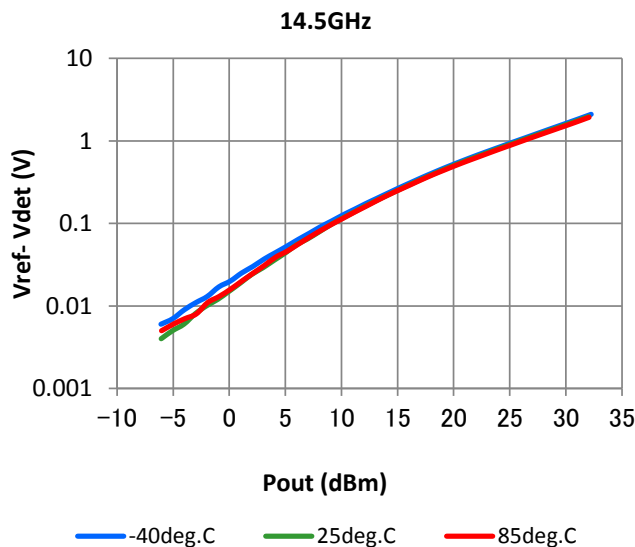
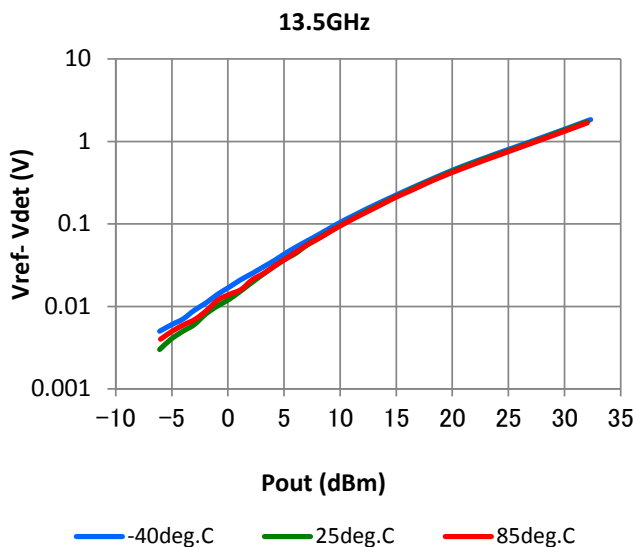
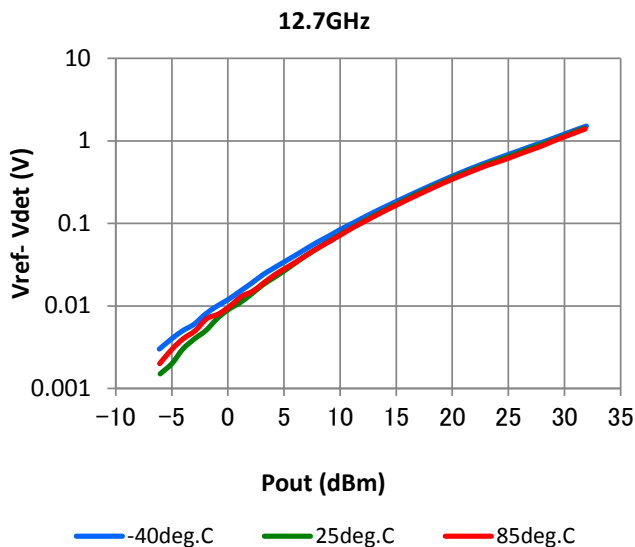

■ S-PARAMETERS

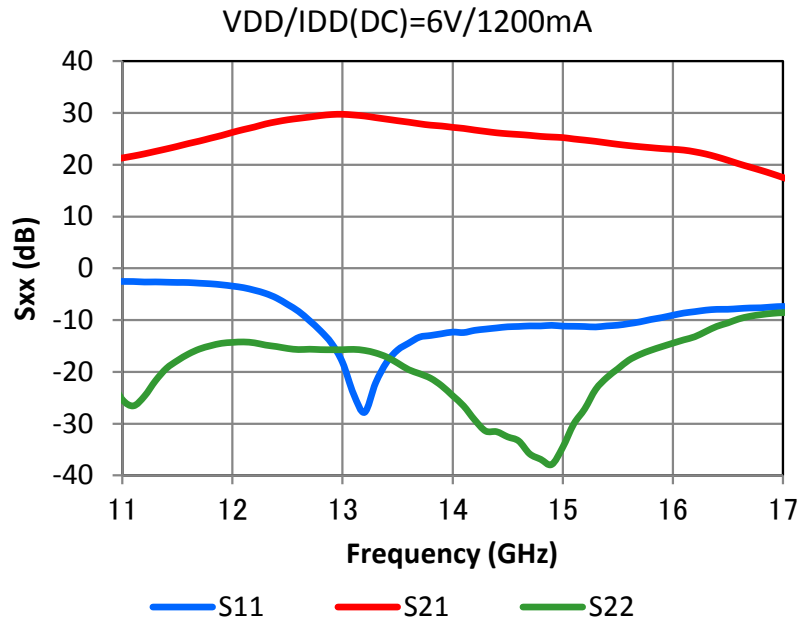
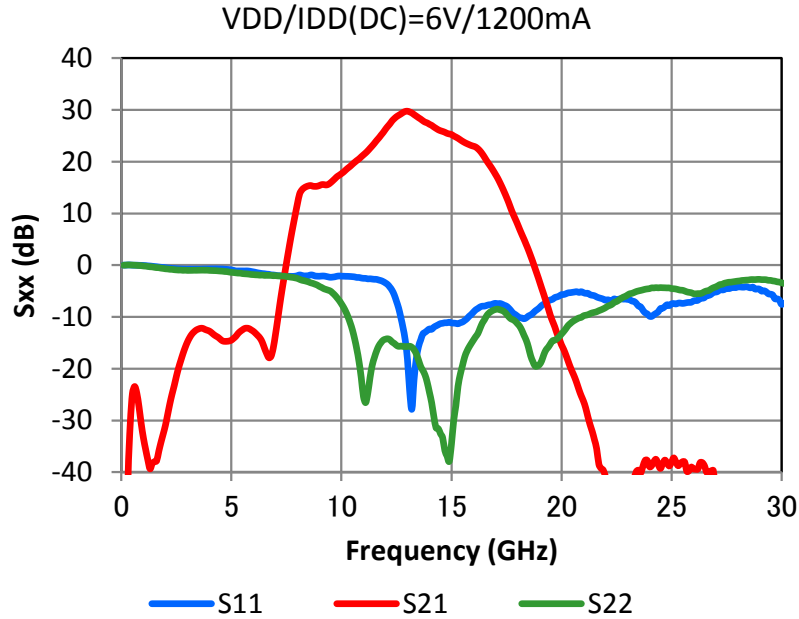

**ΔT_{ch} vs. Drain Voltage
(Reference)**

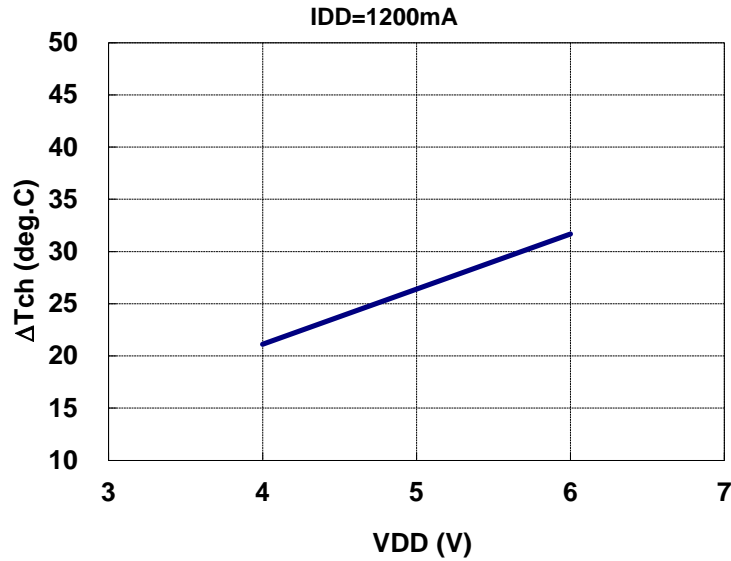

Note: ΔT_{ch} : Temperature Rise from Backside of the Package to Channel.

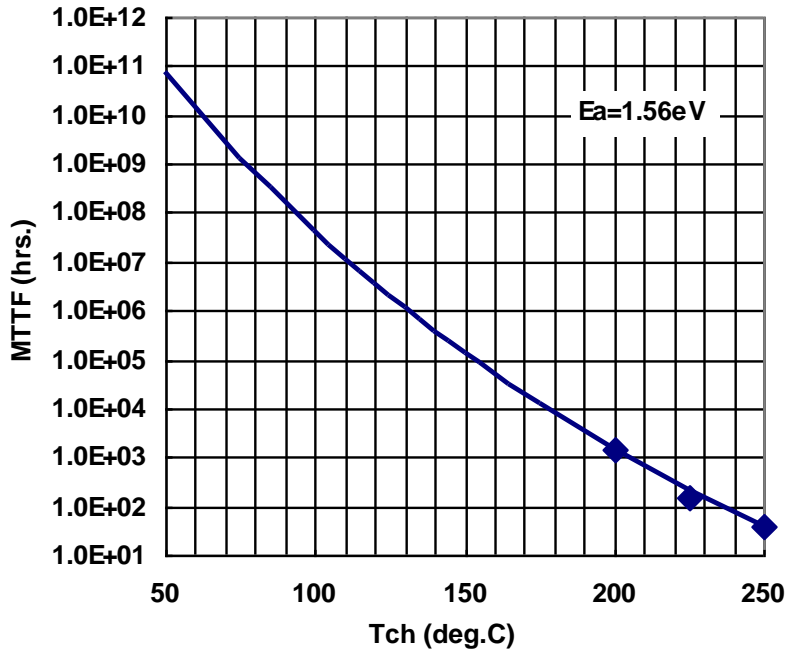

Package Outline and Pin Assignment

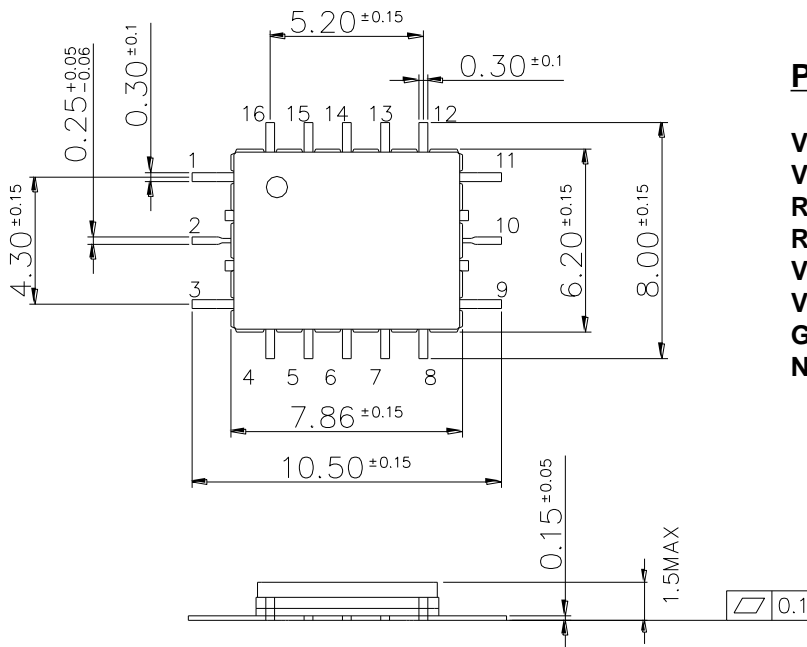

PIN Assignment

- VGG : 1, 3
- VDD : 5, 6, 7, 14, 15
- RF IN : 2
- RF OUT : 10
- Vref : 11
- Vdet : 13
- GND : 4, 8, 12, 16
- N.C. : 9

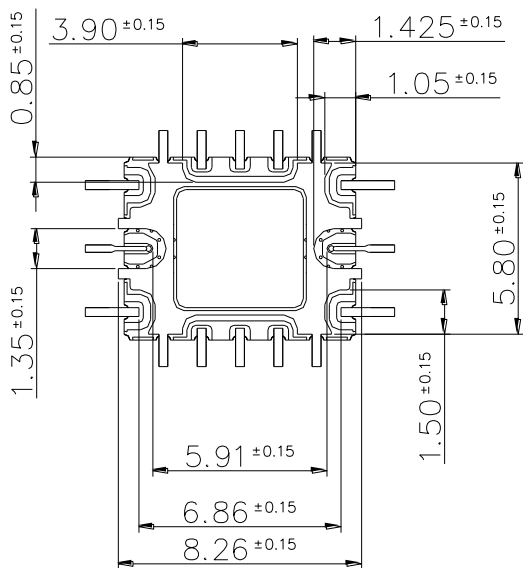

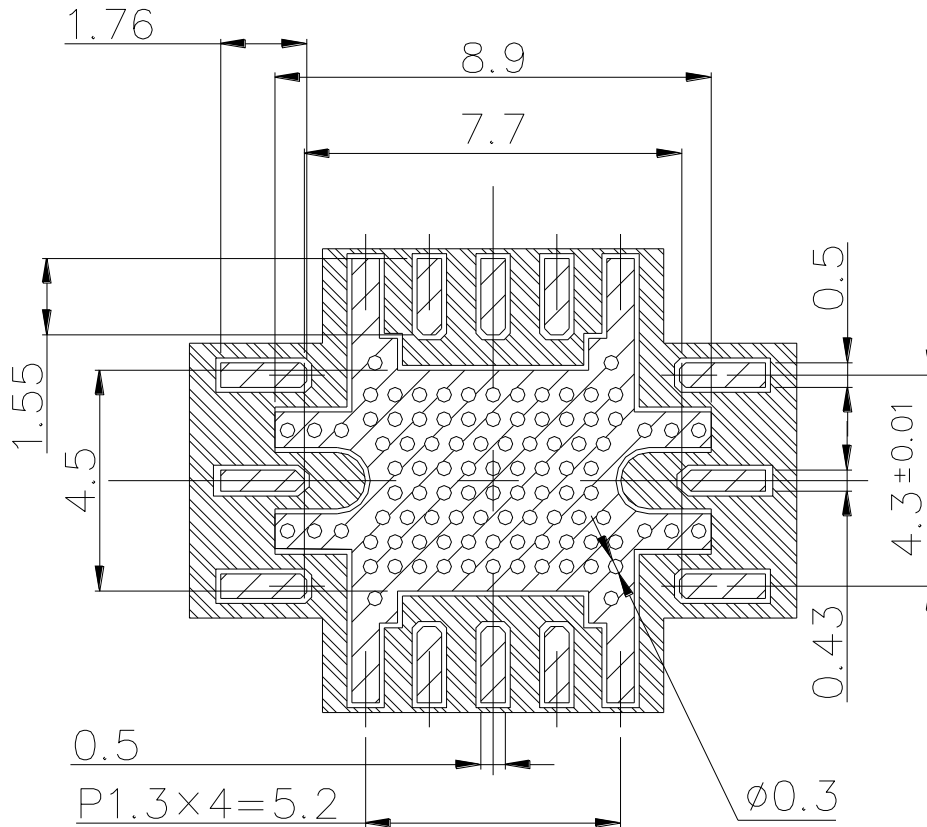

Unit : mm

■PCB Pads and Solder-resist Pattern



NOTES.

- 1). CORE MATERIAL; Rogers CORP. R04003
THICKNESS 0.2mm typ., Er=3.38 typ.
- 2). COPPER FOIL THICKNESS 18µm typ.
- 3). ; FINISH COPPER FOIL; Ni 1µm min./Au 0.1µm max.
- 4). ; RESIST.

Unit : mm

■Block Diagram

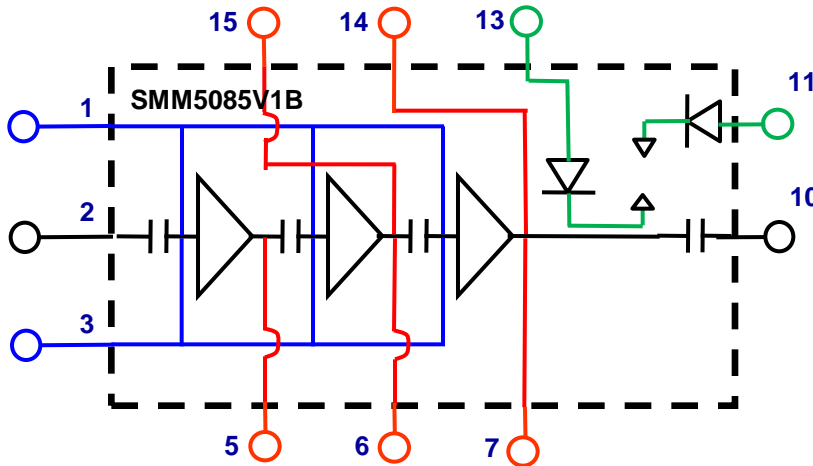

PIN Assignment

VGG : 1, 3
 VDD : 5, 6, 7, 14, 15
 RF IN : 2
 RF OUT : 10
 Vref : 11
 Vdet : 13
 GND : 4, 8, 12, 16
 N.C. : 9

■Recommended Bias Network

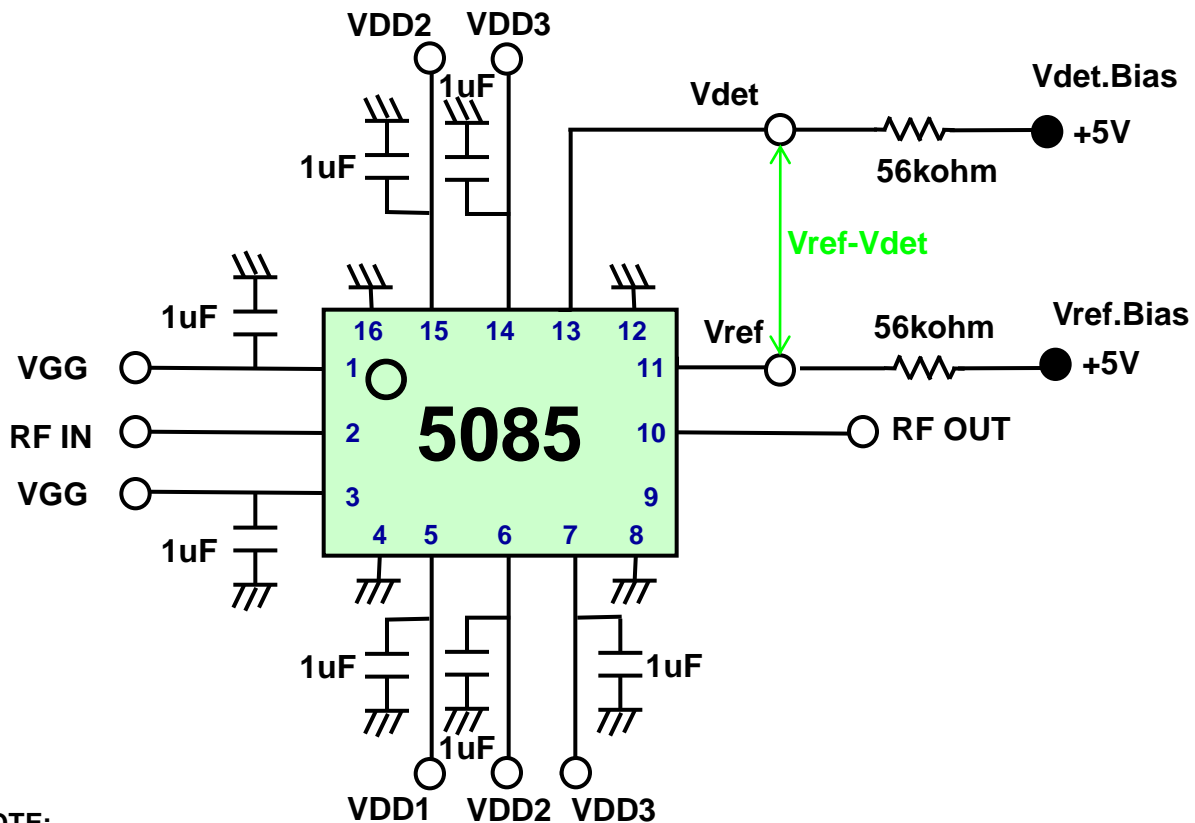

NOTE:

1. The capacitors are recommended on each bias supply lines, close to the package, in order to prevent video oscillations which could damage the module.
2. Two pins named VGG are internally connected.
3. The same pins named VDD are also internally connected.

■ **Marking Information**

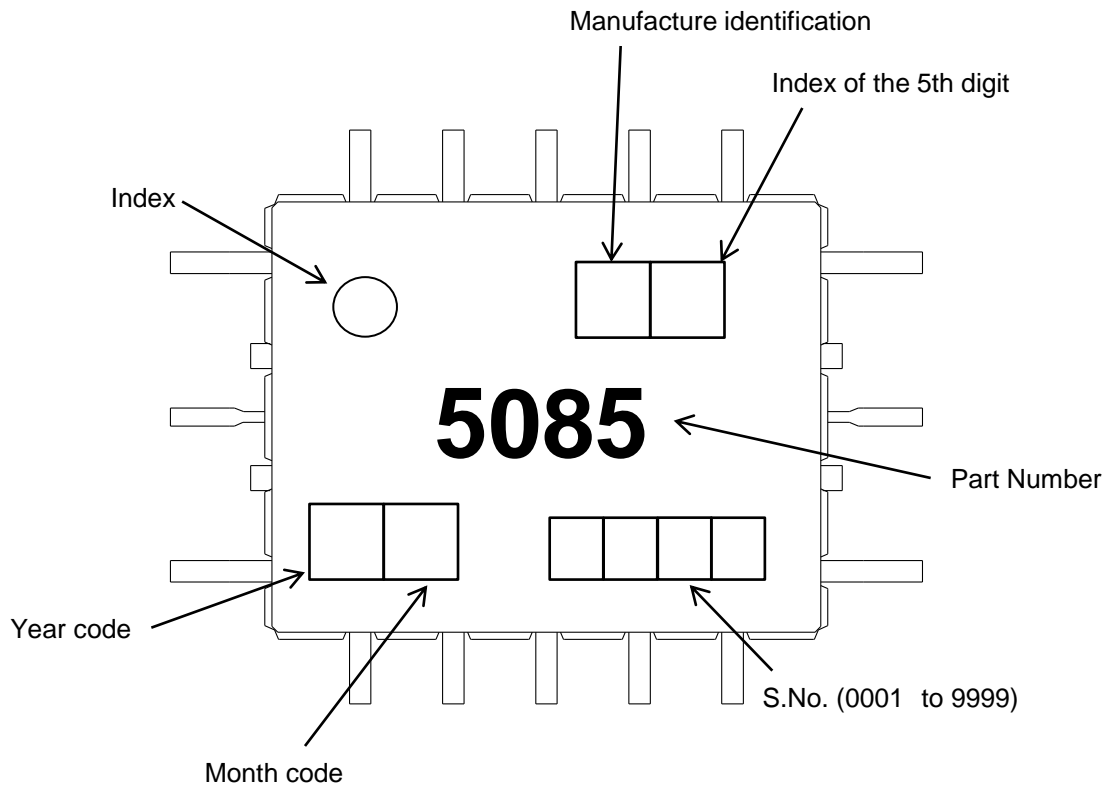

<Year code>

Code	T	U	V	W	X	Y	Z	A	B
Year	2011	2012	2013	2014	2015	2016	2017	2018	2019

<Month code>

Code	H	M	N	P	R	S	T	U	W	X	Y	Z
Month	1	2	3	4	5	6	7	8	9	10	11	12

■ 4-inch Tray Packing (Part No. : SMM5085V1B)

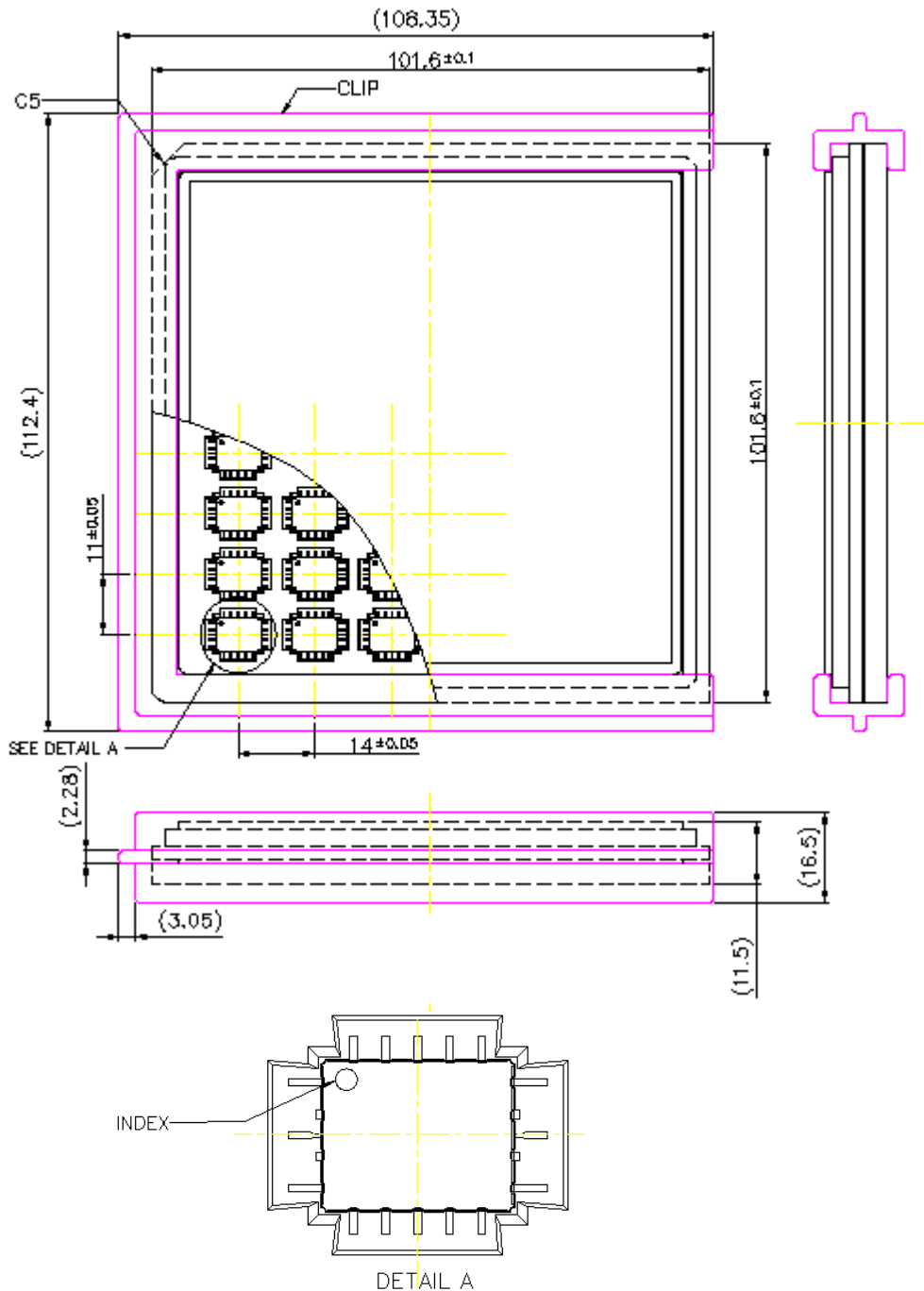

- (1) Maximum Quantity : 48pcs. / Tray
- (2) Tray Material : Conductive PS

■ Tape and Reel Packing (Part No. : SMM5085V1BT)

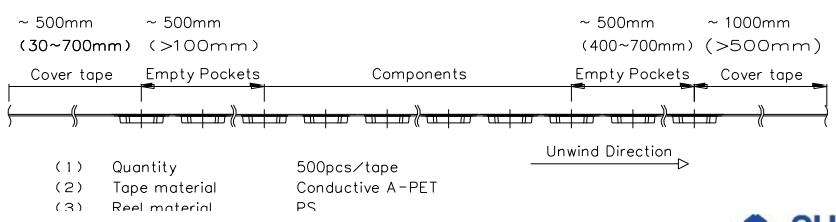
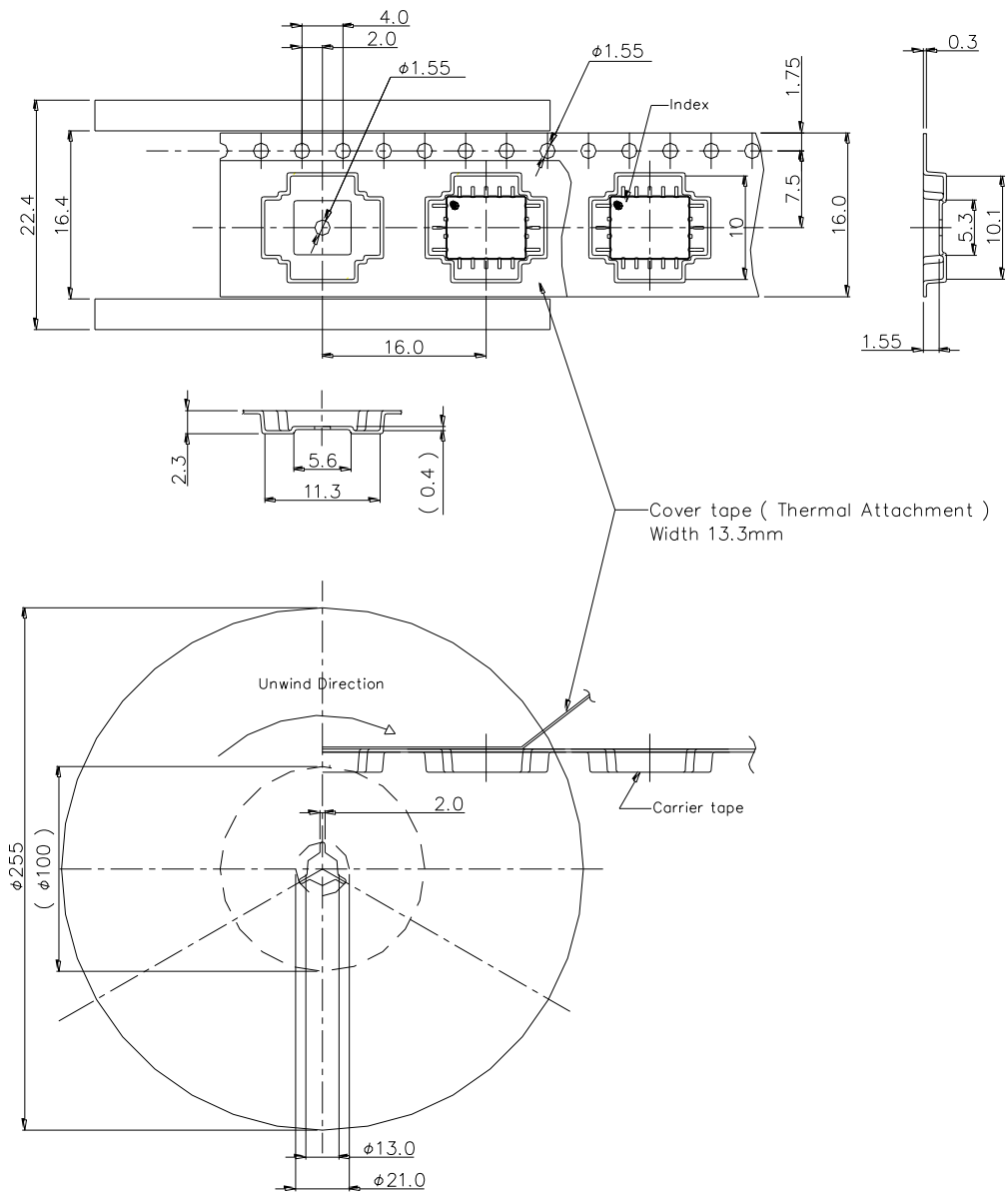

■ **Mounting Method of SMD(Surface Mount Devices) for Lead-free solder**

Mounting Condition

- (1) For soldering, Lead-free solder (Sn-3.0Ag-0.5Cu)*1 or equivalent shall be used.
(*1: The figure displays with weight %. A predominantly tin-rich alloy with 3.0% silver and 0.5% copper.)
- (2) A rosin type flux with a chlorine content of 0.2% or less shall be used. The rosin flux with low halogen content is recommended.
- (3) When soldering, use one of the following time / temperature methods for acceptable solder joints. Make sure the devices have been properly prepared with flux prior soldering.

*** Reflow soldering method (Infrared reflow / Heat circulation reflow / Hot plate reflow):**

Limit solder to 3 reflow cycles because resin is used in the modules manufacturing process. Excessive reflow cycles will effect the resin resulting in a potential failure or latent defect. The recommended reflow temperature profile is shown below. The temperature of the reflow profile must be measured at the device body surface.

Reflow temperature profile and condition:

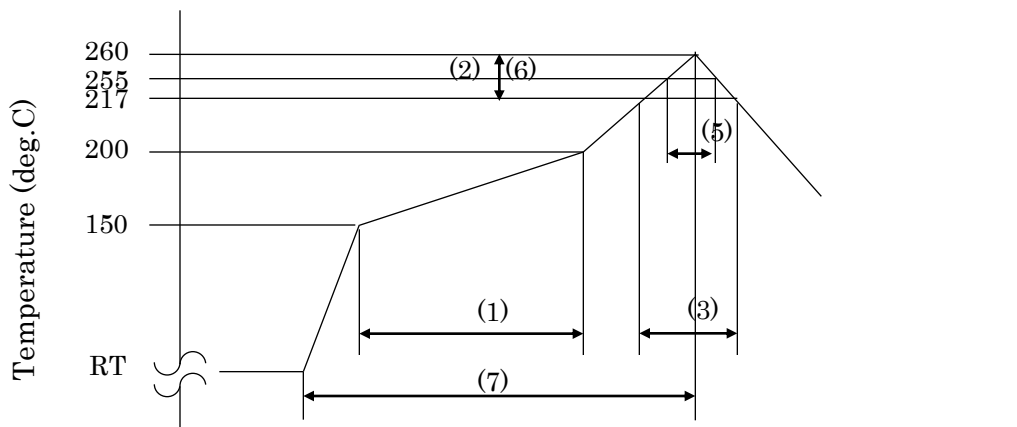

- | | |
|---|-------------------------------------|
| (1) Preheating: | 150 to 200 deg.C, 60 to 120 seconds |
| (2) Ramp-up Rate: | 3 deg.C /seconds max |
| (3) Liquidous temperature and time: | 217 deg.C, 60 to 150 seconds |
| (4) Peak Temperature: | 260 deg.C |
| (5) Time Peak Temperature within 5 deg.C: | under 30seconds |
| (6) Ramp-down Rate: | 6 deg.C /seconds max |
| (7) Time RT to peak temperature: | 8 minutes max |

* Measurement point: Center of the package body surface

- (4) The above-recommended conditions were confirmed using the manufacture's equipment and materials. However, when soldering these products, the soldering condition should be verified by customer using their equipment and materials.



SMM5085V1B

Ku-Band Power Amplifier MMIC

For further information please contact:

<http://global-sei.com/Electro-optic/about/office.html>

CAUTION

This product contains **gallium arsenide (GaAs)** which can be hazardous to the human body and the environment. For safety, observe the following procedures:

- Do not put these products into the mouth.
- Do not alter the form of this product into a gas, powder, or liquid through burning, crushing, or chemical processing as these by-products are dangerous to the human body if inhaled, ingested, or swallowed.
- Observe government laws and company regulations when discarding this product. This product must be discarded in accordance with methods specified by applicable hazardous waste procedures.