

FMM5822VU

K-Band Power Amplifier MMIC

FEATURES

- High Output Power: Pout=32.0dBm (typ.)
- High Linear Gain: GL=22.0dB (typ.)
- Broad Band: 17.7~19.7GHz
- Impedance Matched Zin/Zout=50Ω
- Small Hermetic Metal-Ceramic SMT Package(VU)

DESCRIPTION

The FMM5822VU is a MMIC amplifier that contains a three-stage amplifier, internally matched, for standard communications band in the 17.7 to 19.7GHz frequency range.

Eudyna Devices's stringent Quality Assurance Program assures the highest reliability and consistent performance.

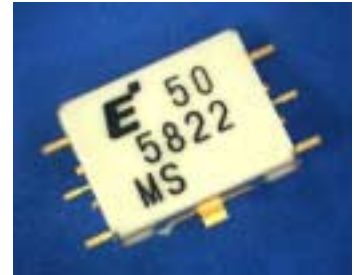

ABSOLUTE MAXIMUM RATING

Item	Symbol	Rating	Unit
Drain-Source Voltage	V _{DD}	10	V
Gate-Source Voltage	V _{GG}	-3	V
Input Power	P _{in}	+25	dBm
Storage Temperature	T _{stg}	-55 to +125	degC

RECOMMENDED OPERATING CONDITIONS

Item	Symbol	Condition	Unit
Drain-Source Voltage	V _{DD}	=< 7	V
Input Power	P _{in}	=< 15	dBm
Operating Case Temperature	T _C	-40 to +85	degC

ELECTRICAL CHARACTERISTICS (Case Temperature Ta=25°C)

Item	Symbol	Test Conditions	Limits			Unit
			Min.	Typ.	Max.	
RF Frequency Range	f	V _{DD} =+6V	17.7	-	19.7	GHz
Output Power at 1dB G.C.P.	P _{1dB}	I _{DD(DC)} =850mA typ.	29	32	-	dBm
Power Gain at 1dB G.C.P.	G _{1dB}	Z _S =Z _L =50ohm	17	21	25	dB
Power-added Efficiency at 1dB G.C.P.	N _{add}		-	24	-	%
Drain Current at 1dB G.C.P.	I _{DDRF}		-	1100	1600	mA
3rd. Order Intermodulation Distortion *	IM ₃	* : df=+10MHz	34	37	-	dBc
Input Return Loss (at Pin=-20dBm)	RL _{IN}	Po=20dBm S.C.L	-	-8	-	dB
Output Return Loss (at Pin=-20dBm)	RL _{OUT}		-	-8	-	dB

G.C.P. : Gain Compression Point
S.C.L. : Single Carrier Level

ESD	Class 0	~199V
-----	---------	-------

Note : Based on EIAJ ED4701 C-111A(C=100pF, R=1.5kohm)

CASE STYLE	VU
------------	----

FMM5822VU

K-Band Power Amplifier MMIC

OUTPUT POWER vs. FREQUENCY

@VDD=6V, IDD(DC)=850mA

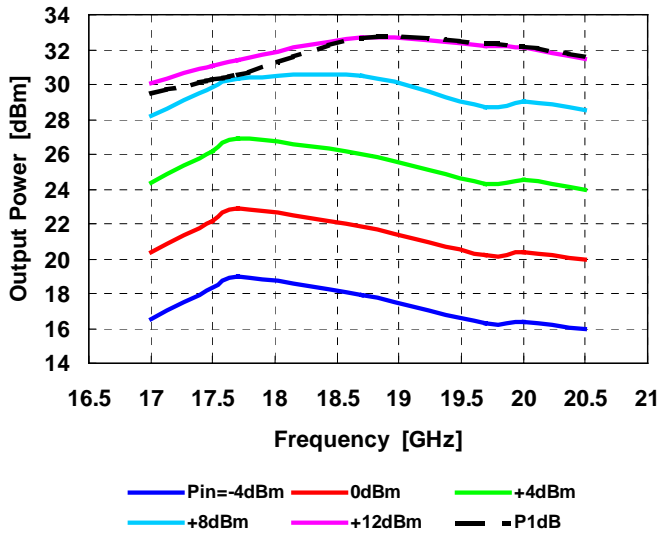

OUTPUT POWER, DRAIN CURRENT vs. INPUT POWER

@VDD=6V, IDD(DC)=850mA

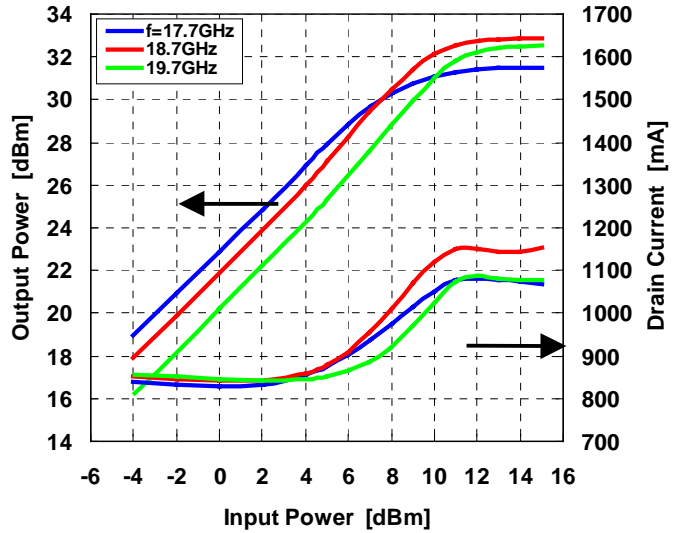

POWER-ADDED EFFICIENCY vs FREQUENCY

@VDD=6V, IDD(DC)=850mA

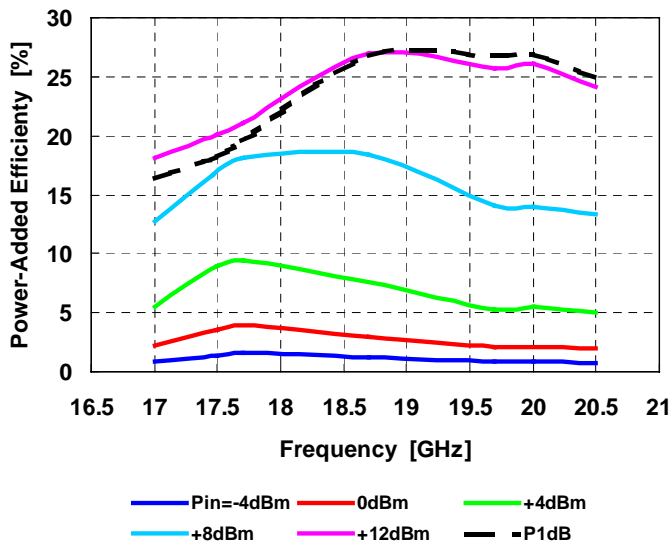

FMM5822VU

K-Band Power Amplifier MMIC

IMD vs. FREQUENCY

@VDD=6V, IDD(DC)=850mA, Po=20dBm S.C.L.

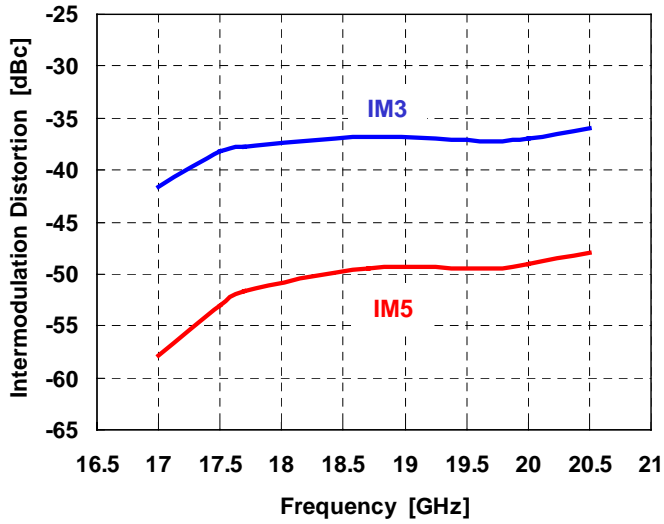

IMD vs. OUTPUT POWER

@VDD=6V, IDD(DC)=850mA

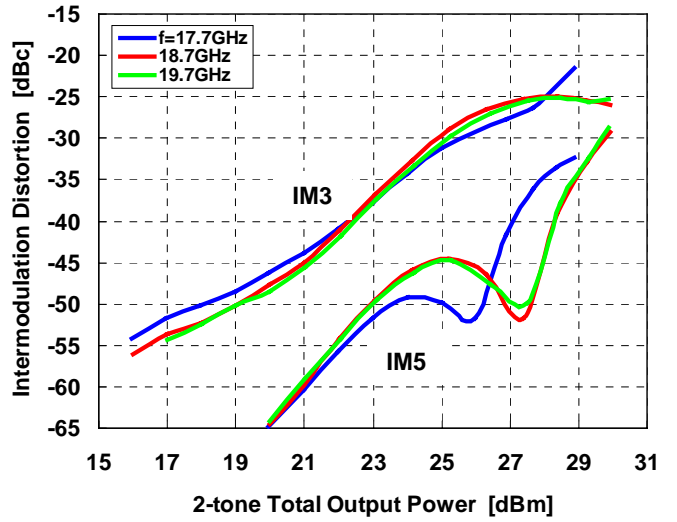

FMM5822VU

K-Band Power Amplifier MMIC

OUTPUT POWER, DRAIN CURRENT vs. INPUT POWER by Drain Voltage

@f=17.7GHz, IDD(DC)=850mA

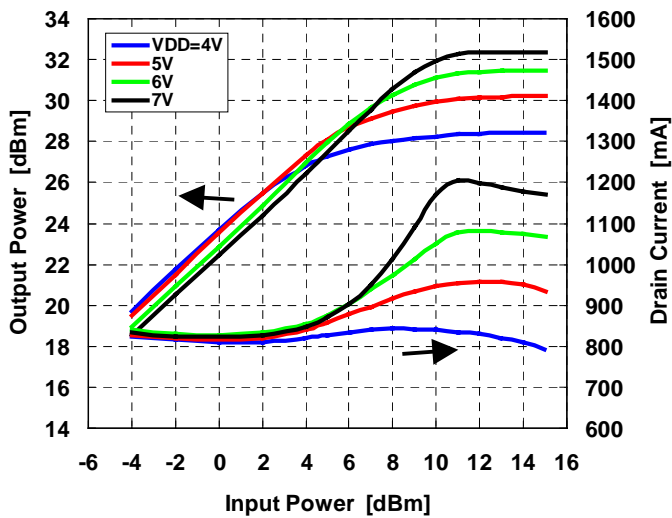

OUTPUT POWER, DRAIN CURRENT vs. INPUT POWER by Drain Voltage

@f=18.7GHz, IDD(DC)=850mA

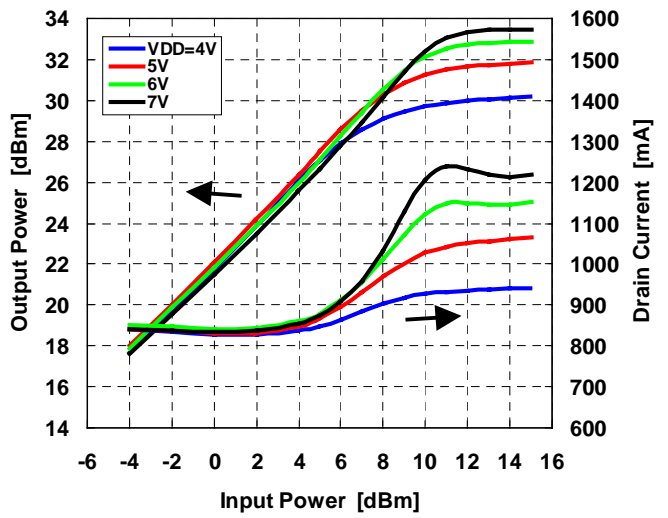

OUTPUT POWER, DRAIN CURRENT vs. INPUT POWER by Drain Voltage

@f=19.7GHz, IDD(DC)=850mA

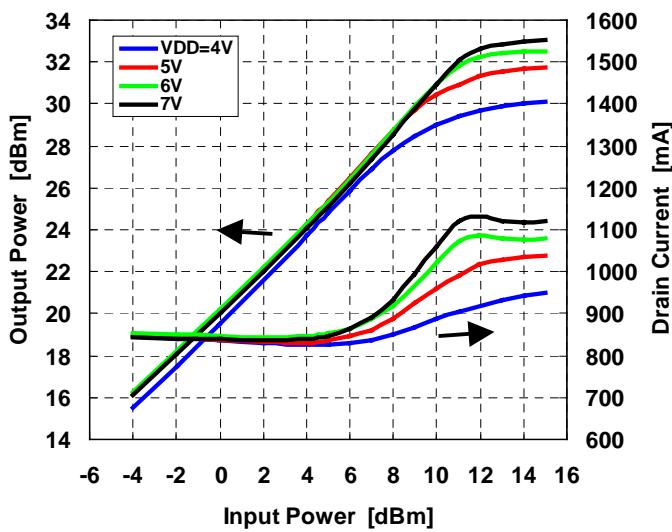

OUTPUT POWER, GAIN vs. DRAIN VOLTAGE

@IDD(DC)=850mA

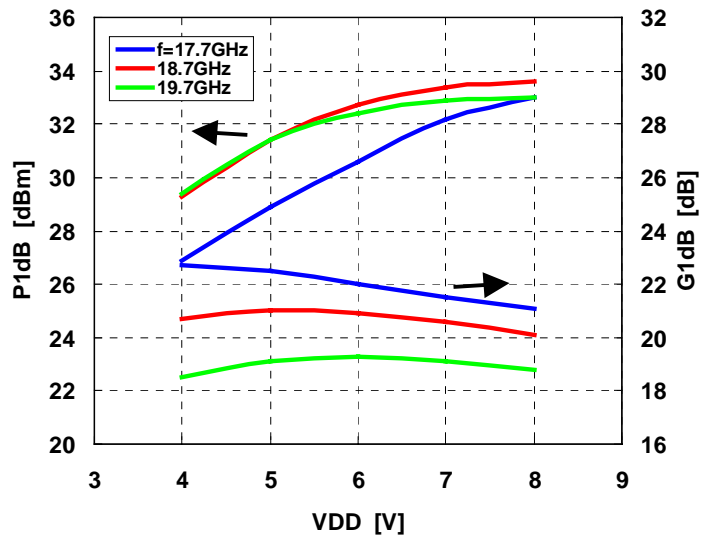

FMM5822VU

K-Band Power Amplifier MMIC

OUTPUT POWER, DRAIN CURRENT
vs. INPUT POWER by Drain Current

@f=17.7GHz, VDD=6V

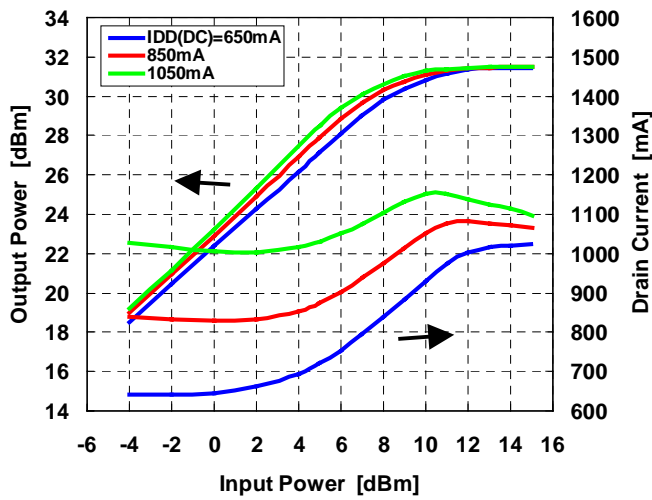

OUTPUT POWER, DRAIN CURRENT
vs. INPUT POWER by Drain Current

@f=18.7GHz, VDD=6V

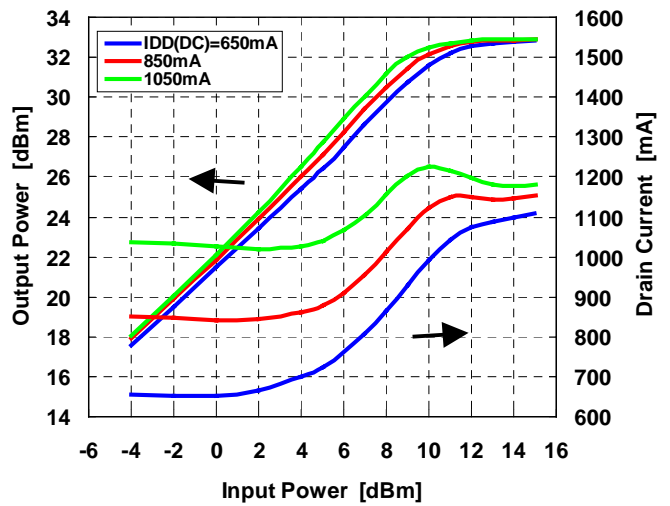

OUTPUT POWER, DRAIN CURRENT
vs. INPUT POWER by Drain Current

@f=19.7GHz, VDD=6V

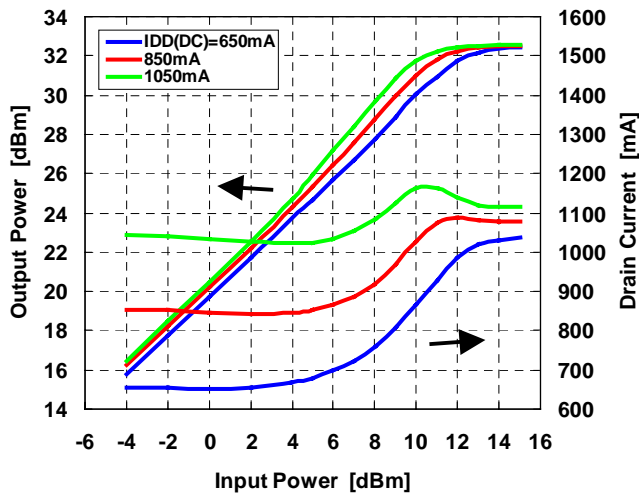

OUTPUT POWER, GAIN vs. DRAIN CURRENT

@VDD=6V

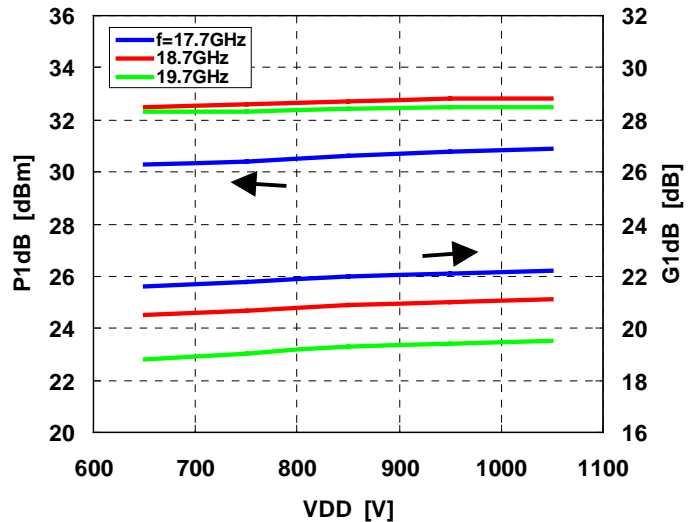

FMM5822 VU

K-Band Power Amplifier MMIC

IMD PERFORMANCE vs OUTPUT POWER
by Drain Voltage

@f=17.7GHz, IDD(DC)=850mA

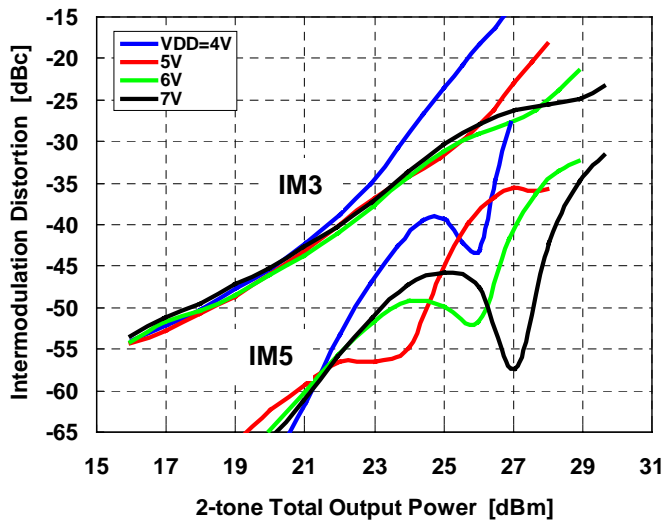

IMD PERFORMANCE vs OUTPUT POWER
by Drain Voltage

@f=18.7GHz, IDD(DC)=850mA

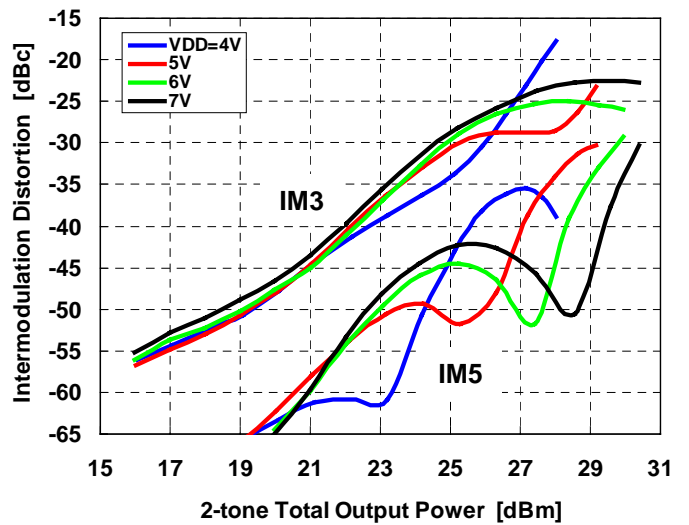

IMD PERFORMANCE vs OUTPUT POWER
by Drain Voltage

@f=19.7GHz, IDD(DC)=850mA

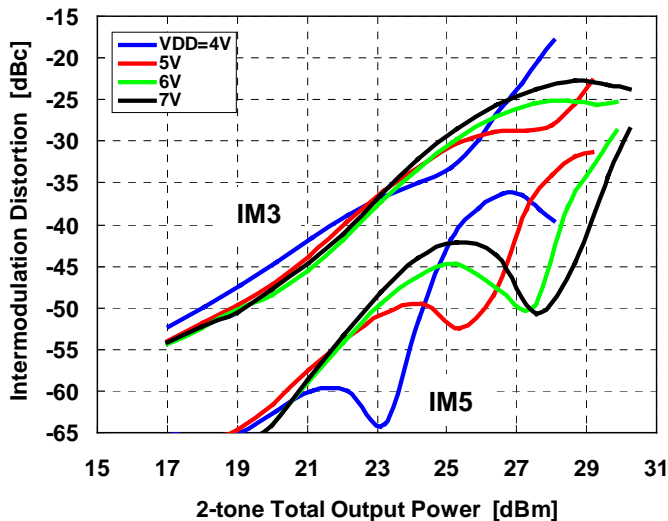

FMM5822VU

K-Band Power Amplifier MMIC

IMD PERFORMANCE vs OUTPUT POWER
by Drain Current

@f=17.7GHz, VDD=6V

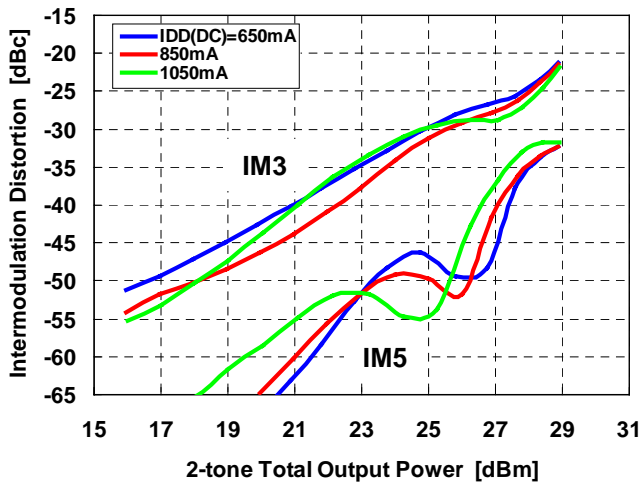

IMD PERFORMANCE vs OUTPUT POWER
by Drain Current

@f=18.7GHz, VDD=6V

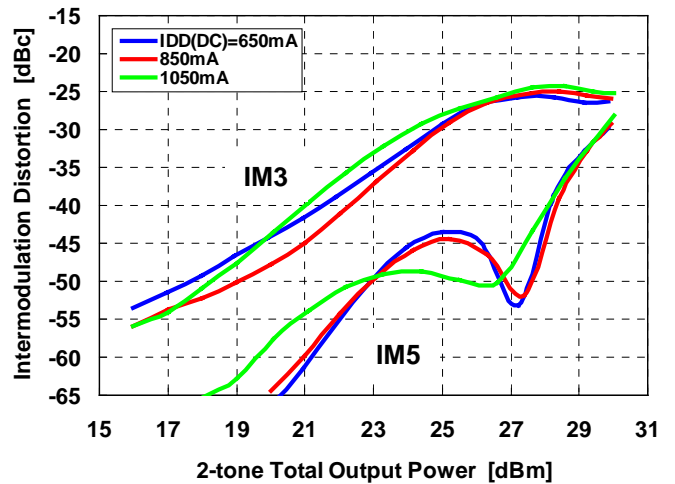

IMD PERFORMANCE vs OUTPUT POWER
by Drain Current

@f=19.7GHz, VDD=6V

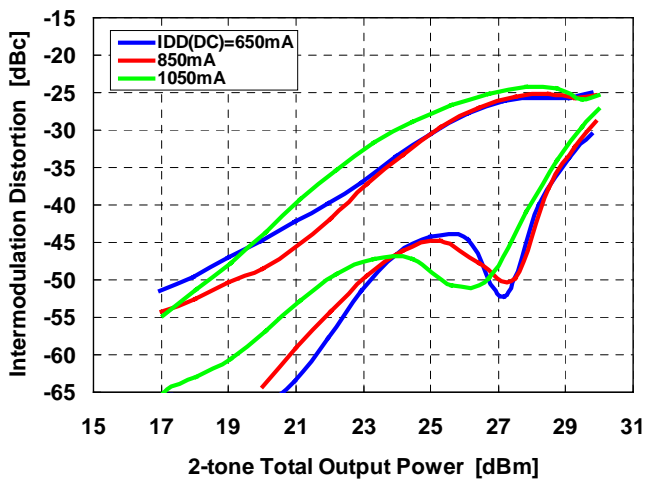

FMM5822VU

K-Band Power Amplifier MMIC

■ S-PARAMETER

VDD=6V, IDD=850mA

Frequency [GHz]	S11		S21		S12		S22	
	MAG	ANG	MAG	ANG	MAG	ANG	MAG	ANG
0.1	1.00	-4.5	0.01	-31.6	0.001	26.9	1.00	-6.0
1.0	0.97	-43.8	0.13	24.9	0.001	1.1	0.97	-58.4
2.0	0.92	-80.3	0.27	153.9	0.001	-166.0	0.90	-101.2
3.0	0.90	-109.6	0.07	94.9	0.001	124.1	0.90	-136.0
4.0	0.88	-141.0	0.19	90.1	0.001	72.2	0.91	-173.1
5.0	0.84	-178.0	0.16	81.0	0.001	52.7	0.90	149.0
6.0	0.84	141.4	0.66	-5.3	0.001	-9.5	0.89	114.1
7.0	0.84	103.6	0.52	-87.6	0.001	-25.2	0.90	82.0
8.0	0.81	67.3	0.66	-127.5	0.001	-85.5	0.89	51.5
9.0	0.71	30.8	0.88	168.2	0.001	-131.7	0.88	20.2
10.0	0.68	-6.8	0.93	106.5	0.001	-157.5	0.88	-8.9
11.0	0.72	-36.3	0.94	53.7	0.001	-152.8	0.88	-29.4
12.0	0.75	-53.0	1.07	9.7	0.003	-72.2	0.88	-43.2
13.0	0.74	-63.8	1.53	-35.1	0.008	-129.0	0.86	-57.5
14.0	0.66	-79.3	2.64	-88.7	0.005	159.6	0.77	-78.0
15.0	0.53	-110.3	4.80	-158.0	0.008	135.7	0.57	-107.2
16.0	0.52	-151.8	7.56	112.9	0.004	118.4	0.37	-134.5
17.0	0.50	168.6	10.68	28.7	0.004	130.1	0.21	-104.9
17.1	0.48	164.0	11.05	19.2	0.004	132.0	0.22	-98.4
17.2	0.46	159.1	11.49	9.7	0.005	128.0	0.25	-92.7
17.3	0.43	153.9	11.95	-0.2	0.005	121.5	0.27	-88.7
17.4	0.40	148.5	12.39	-10.3	0.005	117.2	0.31	-86.2
17.5	0.36	143.3	12.82	-20.8	0.005	112.3	0.34	-85.3
17.6	0.32	136.5	13.14	-31.3	0.005	107.8	0.38	-85.3
17.7	0.27	128.5	13.46	-42.1	0.005	104.2	0.42	-86.0
17.8	0.21	117.0	13.84	-53.0	0.005	96.5	0.46	-87.3
17.9	0.15	100.7	14.18	-64.4	0.005	90.6	0.49	-89.5
18.0	0.10	72.1	14.32	-76.1	0.004	83.2	0.53	-92.1
18.1	0.08	18.4	14.36	-88.1	0.004	76.4	0.55	-95.2
18.2	0.13	-24.4	14.27	-99.6	0.003	66.1	0.58	-98.1
18.3	0.20	-43.9	14.03	-111.4	0.003	61.4	0.59	-101.1
18.4	0.27	-56.5	13.81	-123.0	0.002	52.7	0.60	-104.0
18.5	0.33	-65.9	13.34	-134.4	0.002	53.8	0.60	-106.7
18.6	0.39	-74.4	12.74	-145.4	0.001	54.7	0.60	-109.1
18.7	0.45	-81.5	12.08	-155.7	0.001	65.8	0.60	-110.9
18.8	0.50	-87.4	11.56	-164.4	0.001	111.9	0.59	-112.7
18.9	0.53	-92.6	11.03	-172.9	0.001	142.2	0.59	-114.7
19.0	0.56	-97.2	10.85	178.8	0.001	152.9	0.58	-117.1
19.1	0.59	-102.2	10.64	170.7	0.002	162.0	0.57	-119.8
19.2	0.60	-106.5	10.58	162.0	0.002	160.8	0.55	-122.2
19.3	0.62	-110.3	10.59	153.4	0.002	156.6	0.53	-124.8
19.4	0.62	-114.0	10.62	143.7	0.003	148.8	0.49	-127.0
19.5	0.62	-117.6	10.58	133.9	0.004	141.1	0.46	-127.7
19.6	0.61	-121.2	10.50	123.4	0.004	131.6	0.43	-127.8
19.7	0.60	-124.7	10.30	113.6	0.004	121.6	0.40	-126.7
19.8	0.59	-128.3	10.15	103.8	0.004	114.9	0.38	-125.6
19.9	0.58	-131.9	10.02	94.4	0.004	108.2	0.36	-124.5
20.0	0.57	-136.0	9.99	84.8	0.004	102.9	0.35	-123.9
20.1	0.55	-140.6	10.01	74.5	0.004	99.2	0.34	-123.4
20.2	0.52	-146.8	10.05	64.4	0.005	95.8	0.33	-123.8
20.3	0.50	-153.8	10.06	53.2	0.005	87.8	0.32	-124.5
20.4	0.46	-162.5	10.07	42.0	0.005	78.1	0.31	-126.8
20.5	0.42	-173.6	10.02	30.0	0.005	66.4	0.30	-129.8
21.0	0.28	82.5	9.03	-34.2	0.005	19.0	0.19	-143.1
22.0	0.61	-38.5	3.51	-168.2	0.005	-94.2	0.13	53.7
23.0	0.64	-116.2	0.76	76.2	0.005	-157.8	0.32	-83.6
24.0	0.70	176.2	0.05	15.0	0.004	150.4	0.60	-142.9
25.0	0.69	149.9	0.02	69.9	0.003	149.6	0.70	-164.8
26.0	0.61	146.6	0.02	45.8	0.003	110.4	0.68	-179.8
27.0	0.69	143.8	0.01	18.7	0.001	71.3	0.69	157.3
28.0	0.76	118.3	0.01	-55.1	0.002	-82.9	0.75	130.7
29.0	0.73	89.3	0.01	-122.4	0.003	-179.0	0.66	115.3
30.0	0.69	63.9	0.00	133.0	0.003	112.1	0.62	120.9

FMM5822VU

K-Band Power Amplifier MMIC

■ S-PARAMETER

VDD=6V, IDD(DC)=850mA

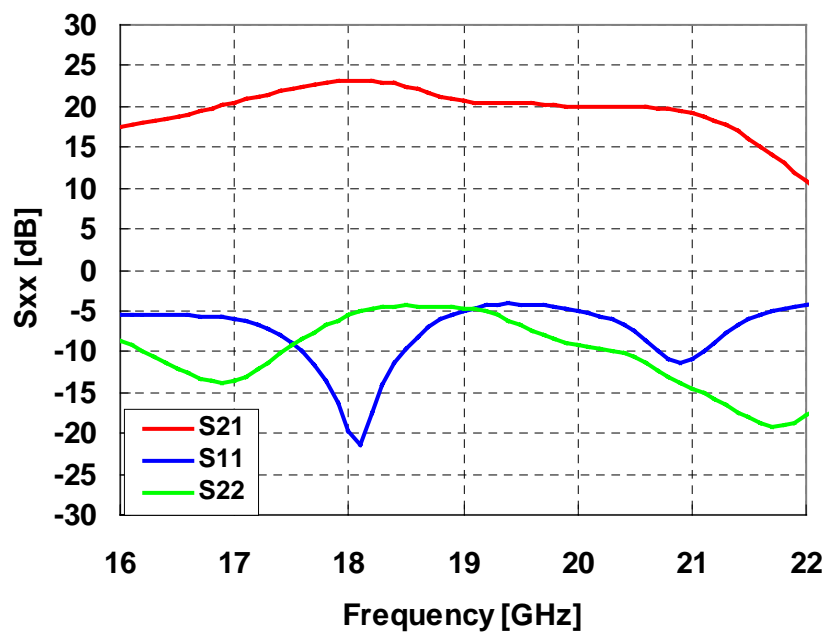
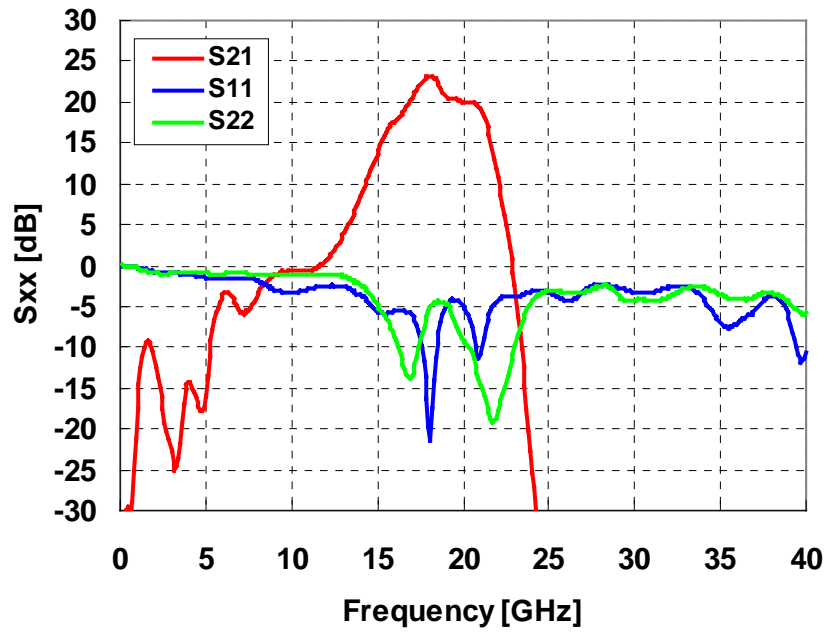

FMM5822VU

K-Band Power Amplifier MMIC

■ Block diagram

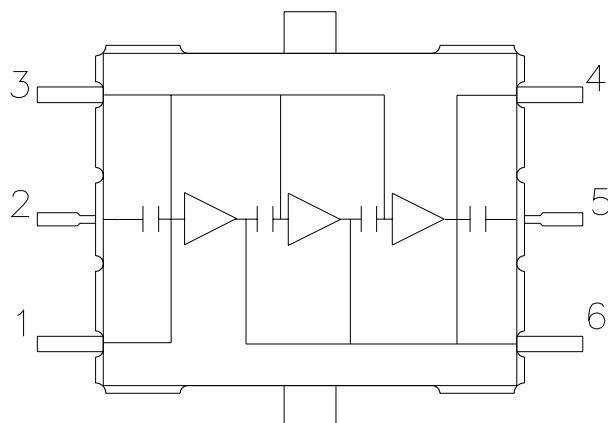

PIN ASSIGNMENT

- 1 : VGG
- 2 : RF in
- 3 : VGG
- 4 : VDD
- 5 : RF out
- 6 : VDD

■ Recommended Bias Circuit

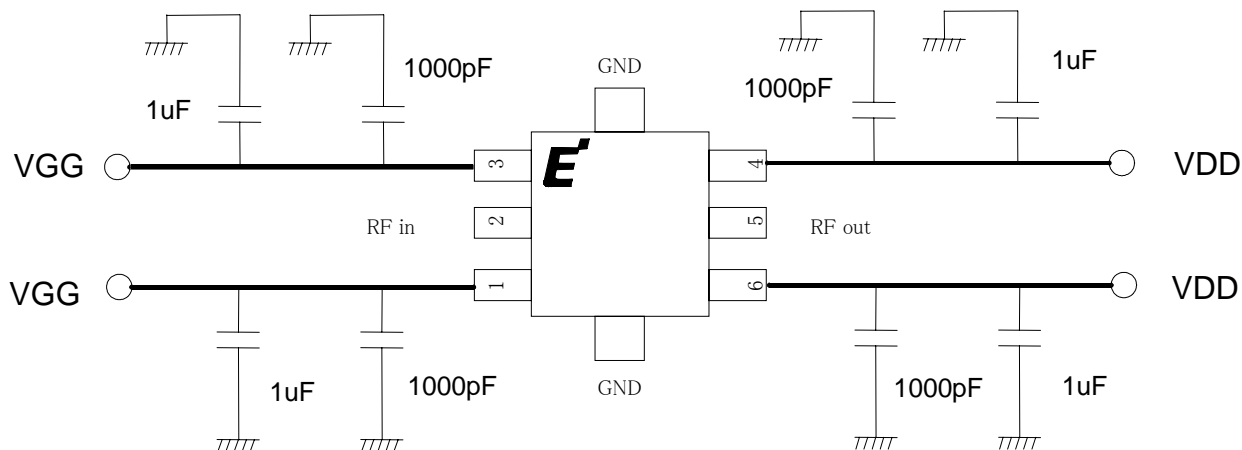

Note 1: The capacitors are recommended on the bias supply line, close to the package, in order to prevent video oscillations which could damage the module.

Note 2: Two pins named VGG are internally connected.

Note 3: Two pins named VDD are internally connected.

FMM5822VU

K-Band Power Amplifier MMIC

■ Package Outline

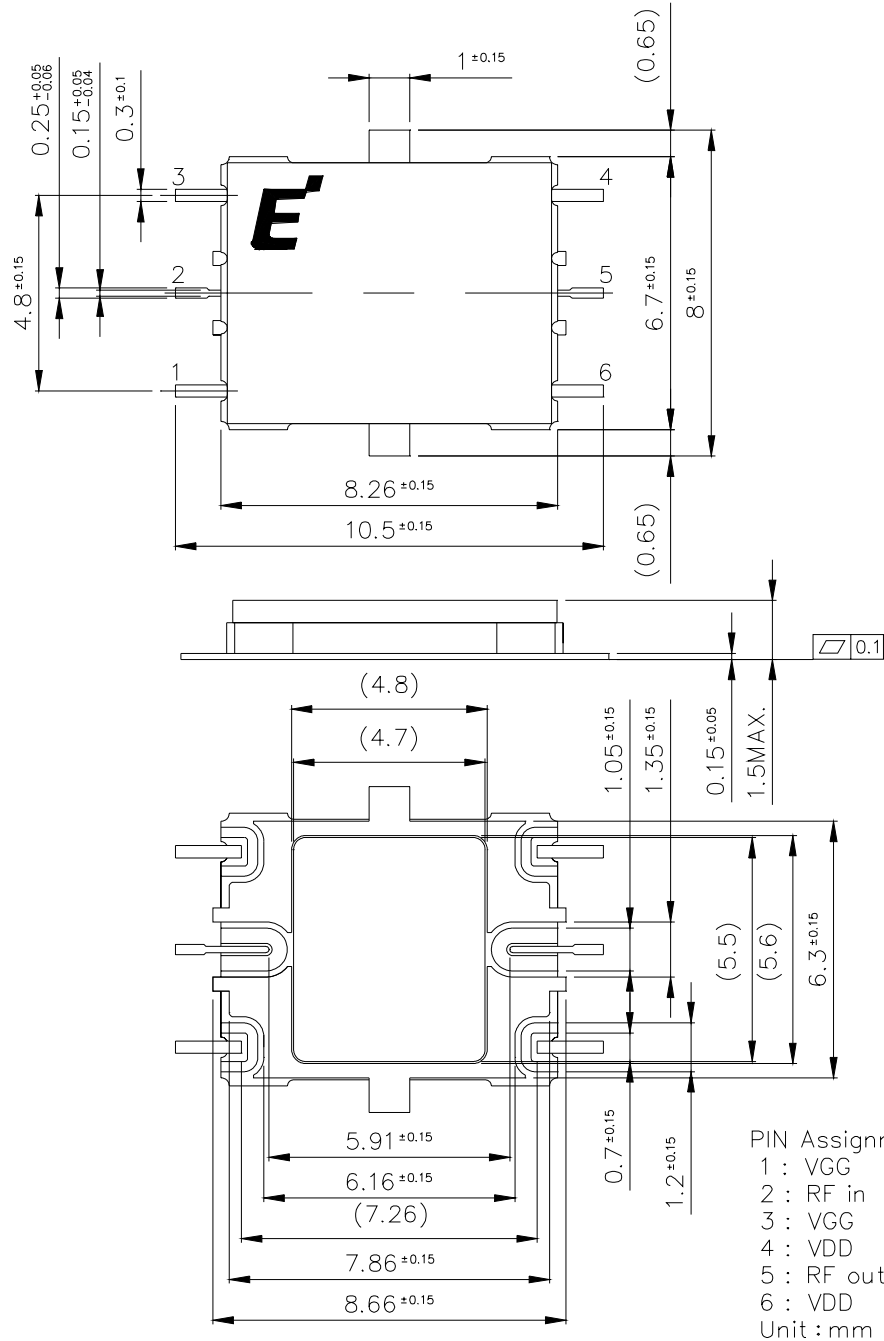

EMM5822VU

K-Band Power Amplifier MMIC

■ PCB Pads and Solder-resist Pattern

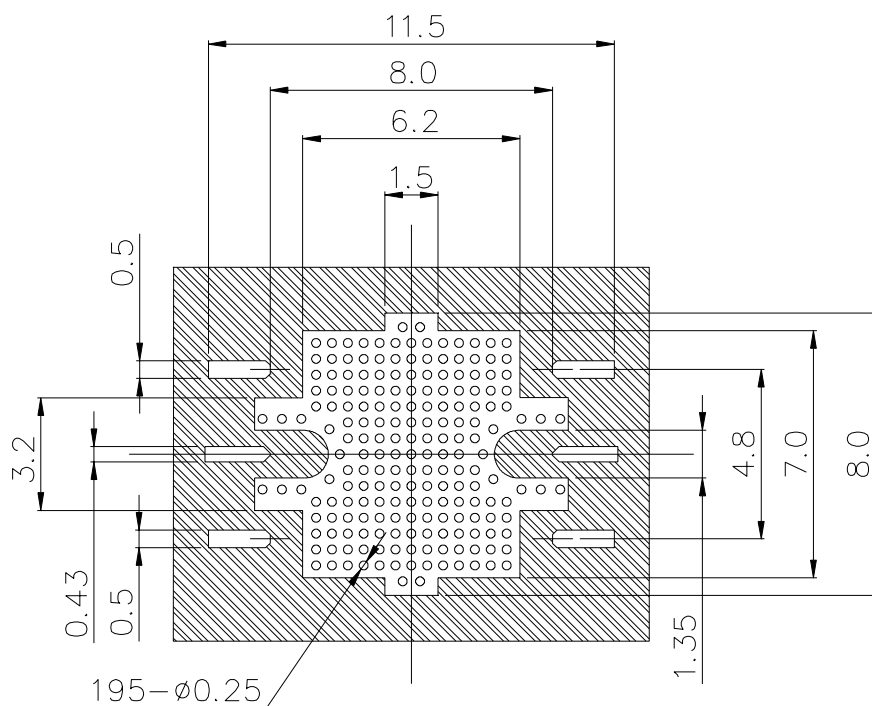

Notes :

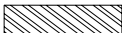
- 1.LAMINATE : Rogers Corporation RO4003, Thickness $t=0.2\text{mm}$, Cu Foil $18\mu\text{m}$
Finish to copper foil ; Ni $0.1\mu\text{m}$ min./Au $0.1\pm 0.08\mu\text{m}$ (Both side)
2.  : Resist

FMM5822VU

K-Band Power Amplifier MMIC

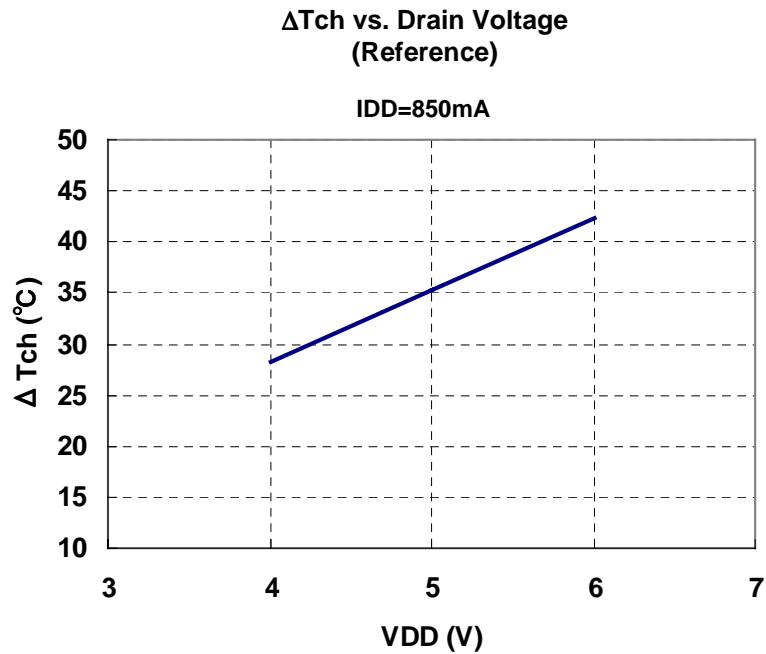

Note: ΔTch : Temperature Rise from Backside of the Package to Channel.

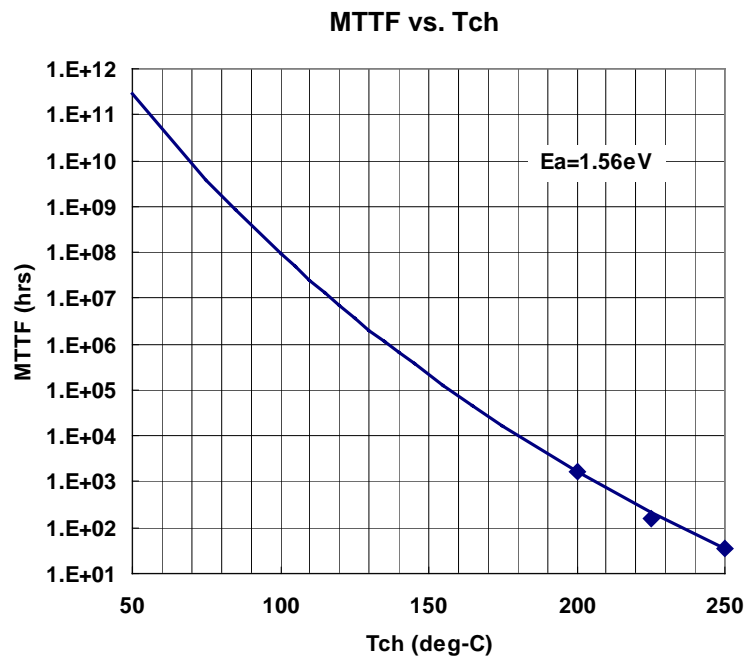

FMM5822VU

K-Band Power Amplifier MMIC

■ Mounting Instructions for VU Package for Lead-free solder

Mounting Condition

1. For soldering, Lead-free solder (Sn-3.0Ag-0.5Cu)*¹ or equivalent shall be used.
(*1: The figure displays with weight %. A predominantly tin-rich alloy with 3.0% silver and 0.5% copper.)
2. A rosin type flux with a chlorine content of 0.2% or less shall be used. The rosin flux with low halogen content is recommended.
3. When soldering, use one of the following time/ temperature methods for acceptable solder joints. Make sure the devices have been properly prepared with flux prior soldering.

* Reflow soldering method (Infrared reflow / Heat circulation reflow / Hot plate reflow):

Limit solder to 3 reflow cycles because resin is used in the modules manufacturing process. Excessive reflow will effect the resin resulting in a potential failure or latent defect. The recommended reflow temperature profile is shown below. The temperature of the reflow profile must be measured at the device lead.

Reflow temperature profile and condition:

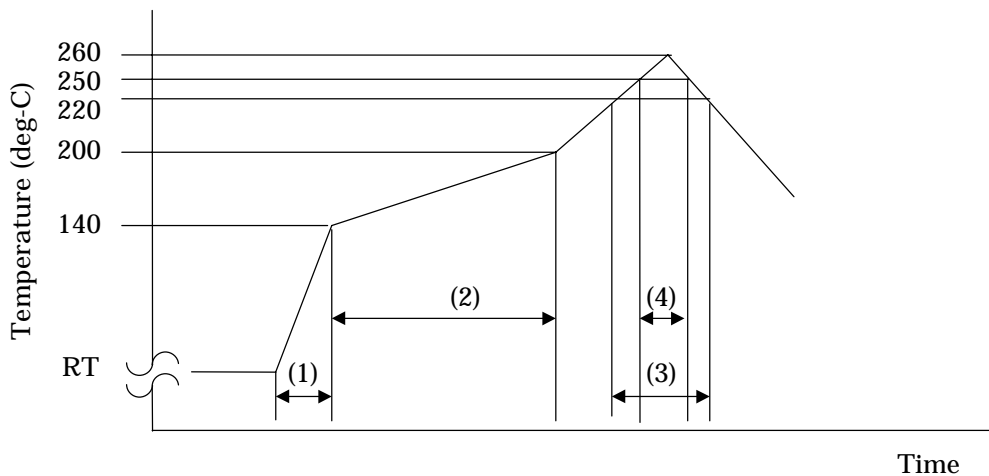

- | | | |
|-----------------------|----------------|-------------------------|
| (1) Temperature rise: | 5deg-C/sec. | |
| (2) Preheating: | 140 - 220deg-C | 60 - 120sec. |
| (3) Main heating: | 220deg-C over. | 10 - 40sec. |
| (4) Main heating: | 250deg-C over. | 10 sec. (260deg-C max.) |

* Measurement point: Device lead.

4. The above-recommended conditions were confirmed using the manufacture's equipment and materials. However, when soldering these products, the soldering condition should be verified by customer using their equipment and materials.

FMM5822VU

K-Band Power Amplifier MMIC

For further information please contact :

Eudyna Devices USA Inc.

2355 Zanker Rd.
San Jose, CA 95131-1138, U.S.A.
TEL: +1 408 232-9500
FAX: +1 408 428-9111

Eudyna Devices Europe Ltd.

Network House
Norreys Drive
Maidenhead, Berkshire SL6 4FJ
United Kingdom
TEL: +44 (0) 1628 504800
FAX: +44 (0) 1628 504888

Eudyna Devices International Srl

Via Teglio 8/2 - 20158
Milano, Italy
TEL: +39-02-8738-1695

Eudyna Devices Asia Pte. Ltd.

Hong Kong Branch
Suite 1906B, Tower 6, China Hong Kong City
33 Canton Road, Tsimshatsui, Kowloon
Hong Kong
TEL: +852-2377-0227
FAX: +852-2377-3921

Eudyna Devices Inc.

1000 Kamisukiahara, showa-cho
Nakakomagun, Yamanashi
409-3883, Japan
(Kokubo Industrial Park)
TEL +81-55-275-4411
FAX +81-55-275-9461

Sales Division

1, Kanai-cho, Sakae-ku
Yokohama, 244-0845, Japan
TEL +81-45-853-8156
FAX +81-45-853-8170

CAUTION

Eudyna Devices Inc. products contain **gallium arsenide (GaAs)** which can be hazardous to the human body and the environment. For safety, observe the following procedures:

- Do not put these products into the mouth.
- Do not alter the form of this product into a gas, powder, or liquid through burning, crushing, or chemical processing as these by-products are dangerous to the human body if inhaled, ingested, or swallowed.
- Observe government laws and company regulations when discarding this product. This product must be discarded in accordance with methods specified by applicable hazardous waste procedures.

Eudyna Devices Inc. reserves the right to change products and specifications without notice. The information does not convey any license under rights of Eudyna Devices Inc. or others.

© 2006 Eudyna Devices Inc.