

FEATURES

- Low Noise Figure : NF = 2.5dB (Typ.) @ f=30 GHz
- High Associated Gain : Gas = 18dB (Typ.) @ f=30 GHz
- Broad Band : 24 - 30 GHz
- High Output Power : P_{1dB} = 6.0dBm (Typ.) @f=30GHz
- Impedance Matched Z_{in}/Z_{out} = 50ohm

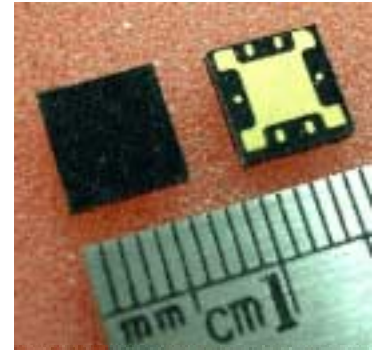

DESCRIPTION

The FMM5703YC is a LNA MMIC designed for applications in the 24 - 30 GHz frequency range. This product is well suited for fixed wireless access, radio link and VSAT applications where low noise and high dynamic range are required.

SEDI's stringent Quality Assurance Program assures the highest reliability and consistent performance.

ABSOLUTE MAXIMUM RATING

Item	Symbol	Rating	Unit
Drain-Source Voltage	V _{DD}	4	V
Input Power	P _{in}	0	dBm
Storage Temperature	T _{stg}	-55 to +125	°C

RECOMMENDED OPERATING CONDITIONS

Item	Symbol	Conditions	Unit
Drain-Source Voltage	V _{DD}	<=3	V
Input Power	P _{in}	<=0	dBm
Operating Backside Temperature	Top	-40 to +85	°C

ELECTRICAL CHARACTERISTICS (Ambient Temperature Ta=25°C)

Item	Symbol	Test Conditions	Limits			Unit
			Min.	Typ.	Max.	
Frequency	Freq	VDD=3.0V	24		30	GHz
Noise Figure	NF	Z _s =Z _l =50ohm	-	2.5 ^{*1}	3 ^{*1}	dB
Associated Gain	Gas	*1:Freq=30GHz	15 ^{*1}	18 ^{*1}	21 ^{*1}	dB
Output Power at 1dB G.C.P.	P _{1dB}		-	6.0	-	dBm
Drain Current	I _{DD}		-	20	-	mA
Input Return Loss (at Pin=-20dBm)	RL _{in}		-	-8	-	dB
Output Return Loss (at Pin=-20dBm)	RL _{out}		-	-8	-	dB

G.C.P.:Gain Compression Point

ESD	Class 0	~ 250V
-----	---------	--------

Note : Based on JEDEC JESD22-A114-C

Case Style	YC
RoHS Compliance	Yes

ORDERING INFORMATION

Part Number	Order Unit	Packing
FMM5703YC	No Limitation	64 pcs./Tray × 4 Tray = 256 pcs./Packing
FMM5703YCT	500pcs.	500 pcs./Reel × 1 Reel = 500 pcs./Packing

NOISE FIGURE, ASSOCIATED GAIN vs. FREQUENCY

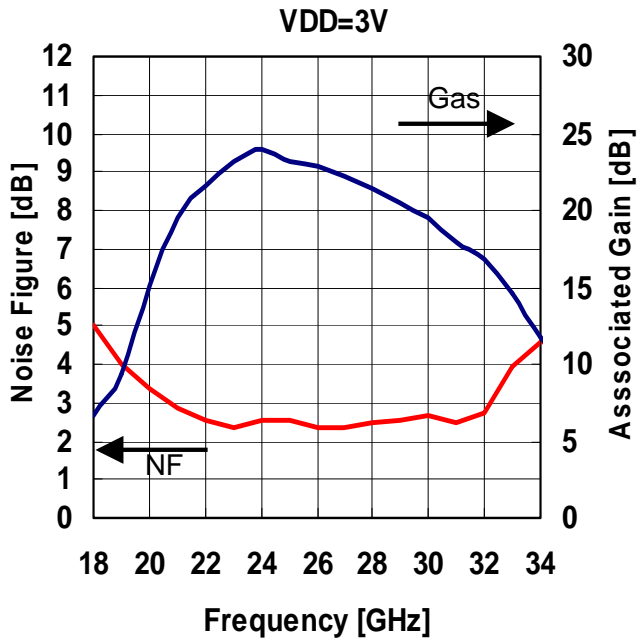

OUTPUT POWER vs. FREQUENCY

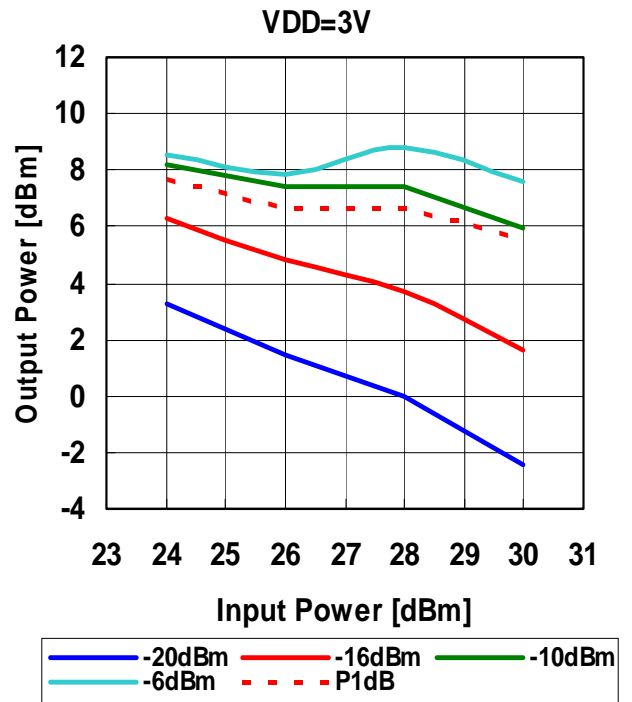

OUTPUT POWER, DRAIN CURRENT vs. INPUT POWER

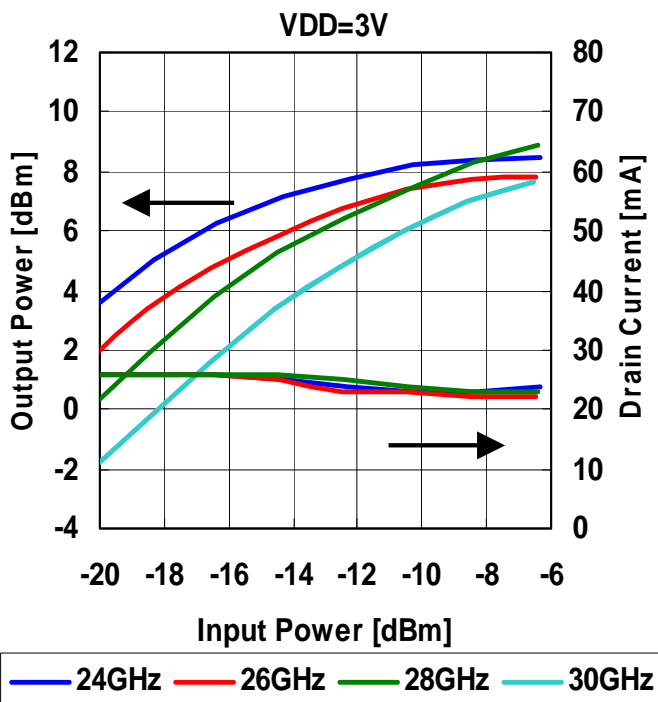

NOISE FIGURE, ASSOCIATED GAIN vs. FREQUENCY
by Temperature

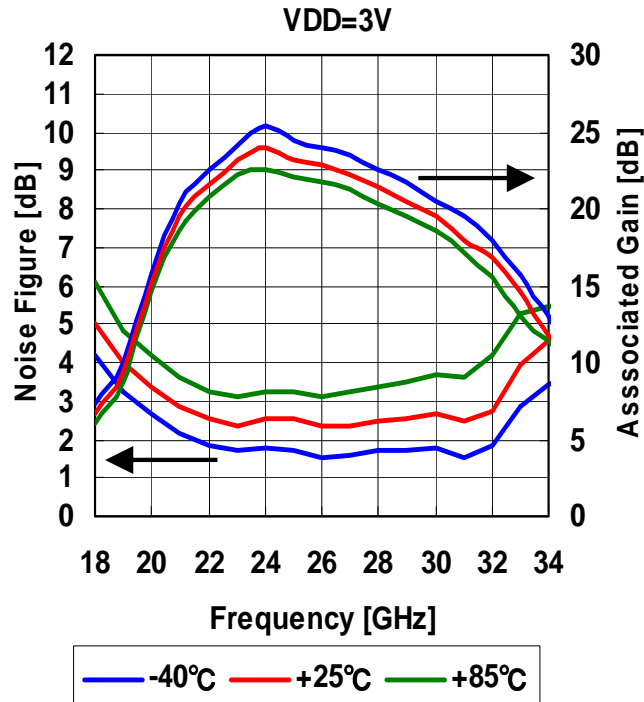

NOISE FIGURE, ASSOCIATED GAIN
vs. TEMPERATURE

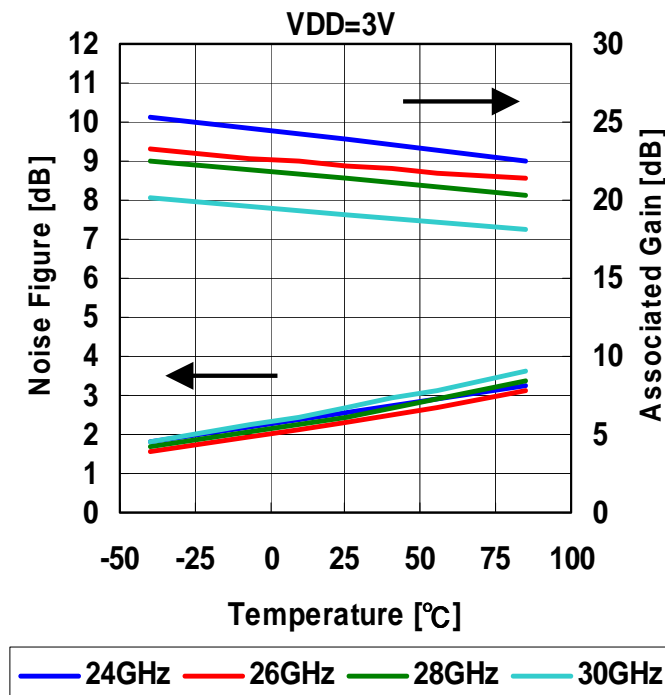

OUTPUT POWER, DRAIN CURRENT vs. INPUT POWER by Temperature

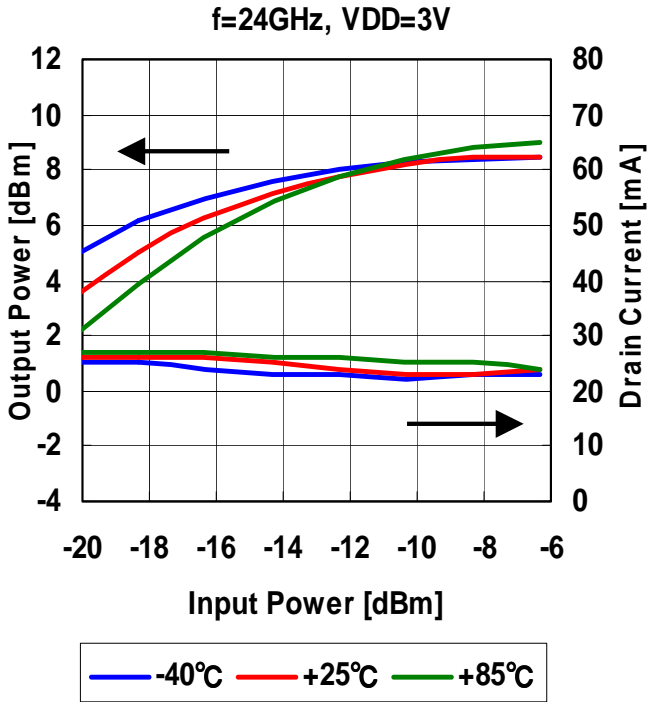

OUTPUT POWER, DRAIN CURRENT vs. INPUT POWER by Temperature

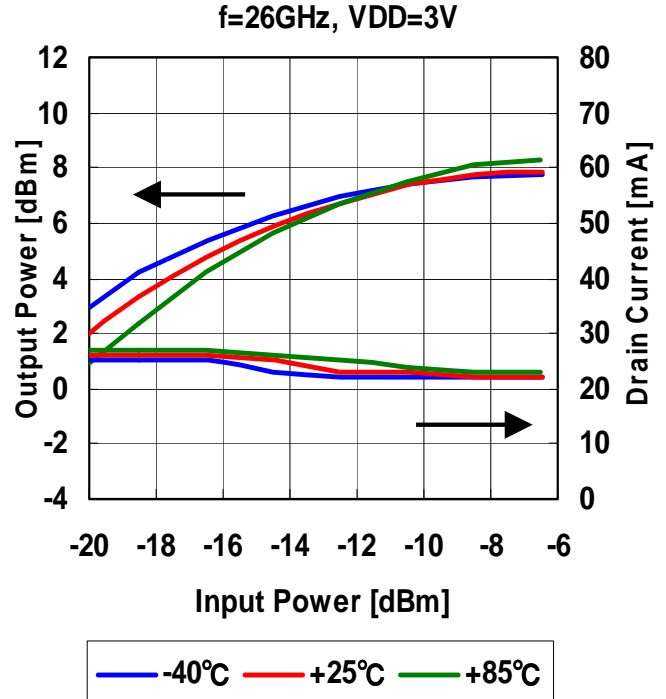

OUTPUT POWER, DRAIN CURRENT vs. INPUT POWER by Temperature

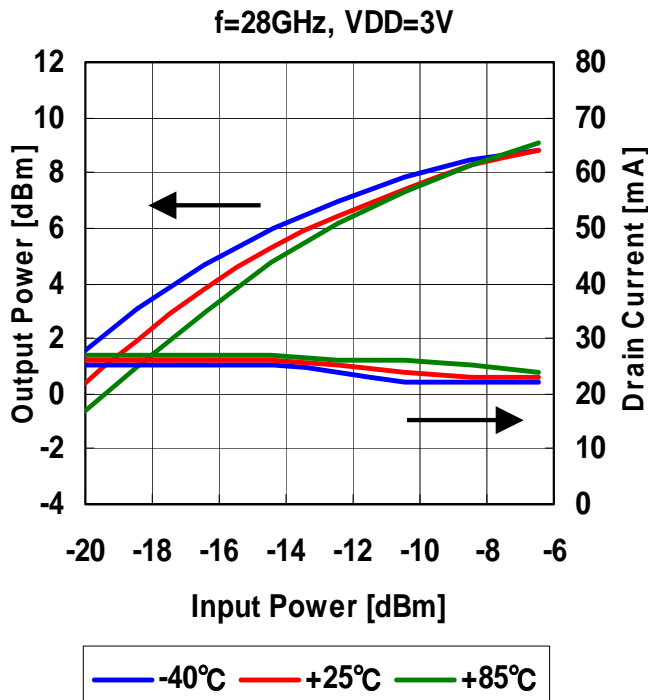

OUTPUT POWER, DRAIN CURRENT vs. INPUT POWER by Temperature

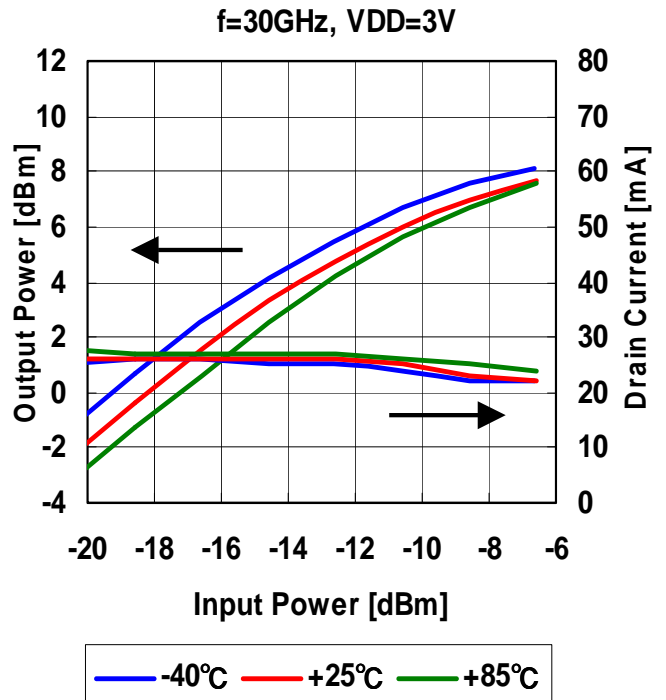

■ S-PARAMETER

VDD=3V

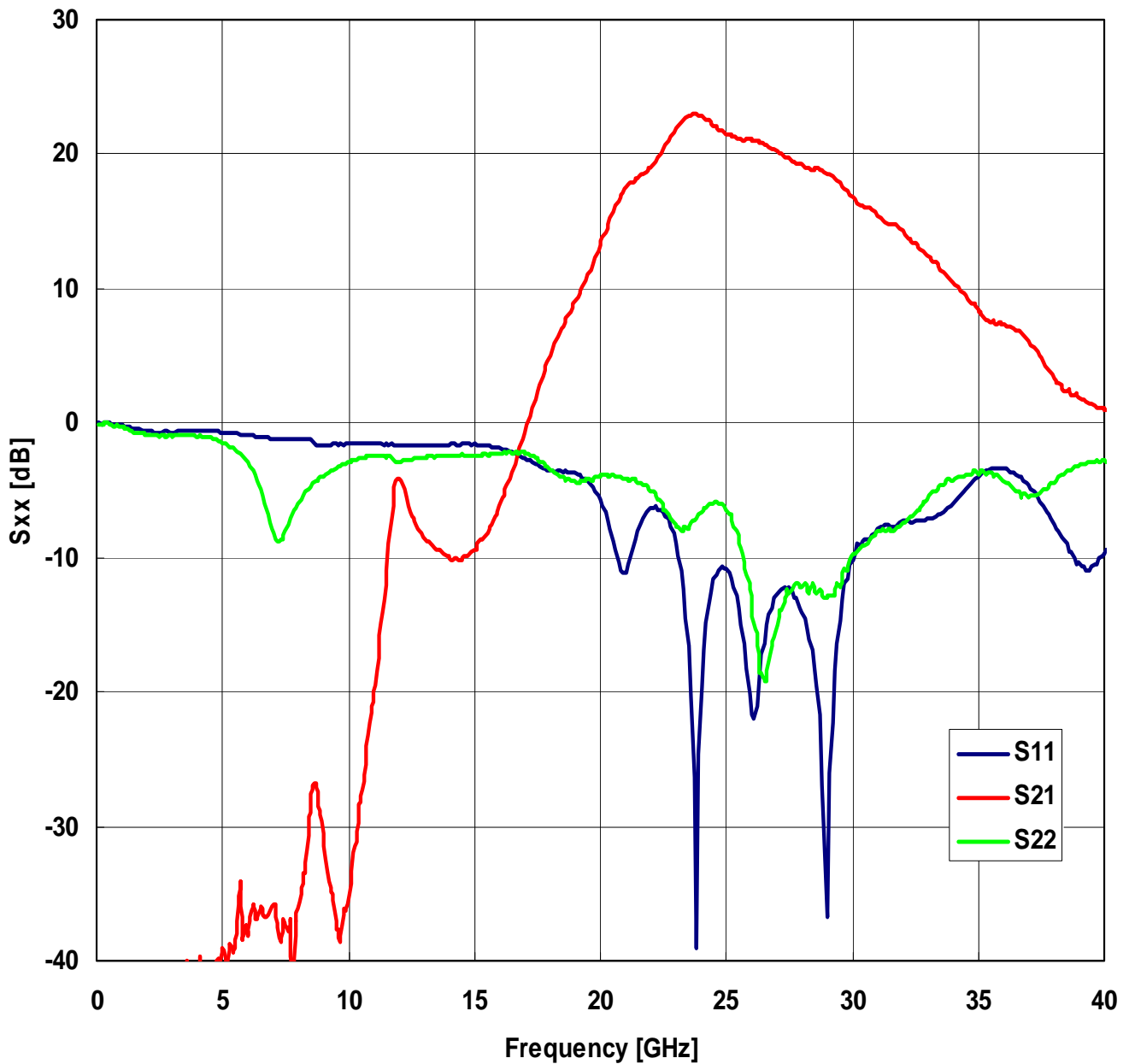

■ S-PARAMETER

VDD=3V

Frequency [GHz]	S11		S21		S12		S22	
	MAG	ANG	MAG	ANG	MAG	ANG	MAG	ANG
1.0	0.986	-122.2	0.001	-101.1	0.000	-50.7	0.962	-116.5
2.0	0.937	125.2	0.003	133.8	0.000	143.3	0.907	136.7
3.0	0.922	16.4	0.003	-49.6	0.001	-42.1	0.894	35.2
4.0	0.939	-100.8	0.005	-174.9	0.003	-171.2	0.894	-73.3
5.0	0.926	138.3	0.011	51.7	0.005	63.6	0.837	169.2
6.0	0.904	26.3	0.012	-87.8	0.007	-58.4	0.717	54.6
7.0	0.874	-83.9	0.016	122.9	0.007	-176.7	0.393	-38.0
8.0	0.869	145.0	0.016	-83.2	0.009	91.5	0.503	-110.8
9.0	0.821	6.8	0.030	8.5	0.011	-34.2	0.631	117.0
10.0	0.840	-107.0	0.018	-45.7	0.010	-149.1	0.716	-10.4
11.0	0.842	148.7	0.096	-133.3	0.009	105.5	0.755	-118.9
12.0	0.828	37.6	0.622	32.0	0.009	2.6	0.719	140.0
13.0	0.825	-81.7	0.375	-143.4	0.006	-101.6	0.744	32.8
14.0	0.827	167.8	0.318	89.8	0.004	160.1	0.753	-78.2
15.0	0.835	74.5	0.340	-18.9	0.002	73.6	0.761	-175.3
16.0	0.805	-19.0	0.494	-122.7	0.001	169.7	0.771	98.0
17.0	0.748	-125.7	0.919	123.8	0.008	29.1	0.769	9.5
18.0	0.663	99.1	1.785	-5.3	0.013	-109.2	0.671	-91.1
19.0	0.650	-36.5	2.852	-139.1	0.013	121.1	0.609	155.1
20.0	0.515	-161.2	4.618	89.8	0.012	-4.7	0.633	50.4
21.0	0.277	0.6	7.518	-56.6	0.008	-132.9	0.619	-39.0
22.0	0.480	-165.7	8.850	161.0	0.004	131.0	0.559	-131.4
23.0	0.359	84.8	12.504	19.6	0.005	34.1	0.413	99.6
24.0	0.103	163.0	13.936	-135.0	0.003	-116.7	0.464	-58.6
25.0	0.287	64.8	11.936	83.1	0.003	38.6	0.474	-166.3
26.0	0.083	37.0	11.202	-52.0	0.008	-111.6	0.204	79.3
27.0	0.233	34.6	10.193	170.9	0.012	122.5	0.176	-133.4
28.0	0.198	-43.2	9.187	40.1	0.015	3.7	0.247	114.5
29.0	0.015	85.7	8.485	-93.0	0.018	-114.9	0.225	-19.6
30.0	0.311	-27.0	6.911	134.2	0.017	117.8	0.326	-172.2
31.0	0.405	-97.3	5.912	6.3	0.014	-4.5	0.397	90.8
32.0	0.432	-168.3	5.179	-121.7	0.015	-126.0	0.427	-2.5
33.0	0.439	99.4	4.194	112.0	0.018	116.1	0.520	-104.8
34.0	0.502	-14.3	3.353	-12.9	0.021	-3.8	0.615	166.1
35.0	0.635	-131.2	2.596	-135.3	0.019	-117.2	0.647	90.2
36.0	0.674	122.7	2.332	107.4	0.017	138.3	0.614	1.4
37.0	0.587	26.8	2.006	-19.1	0.015	33.9	0.524	-118.0
38.0	0.421	-68.6	1.465	-141.4	0.011	-65.3	0.604	130.5
39.0	0.302	-158.0	1.248	106.7	0.009	-151.9	0.690	55.2
40.0	0.328	150.2	1.114	-7.0	0.012	88.8	0.729	-7.3

■ Package Outline and Pin Assignment

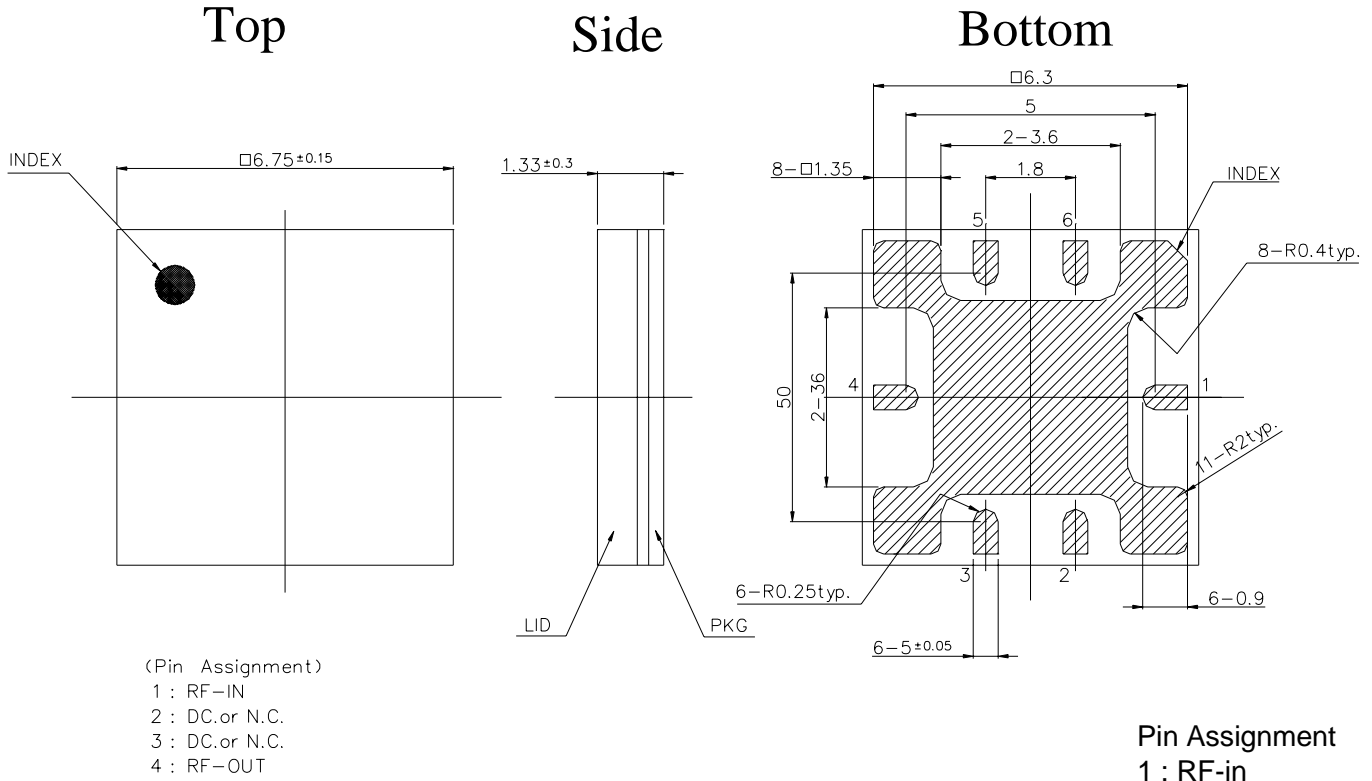

■ Block Diagram and External Component

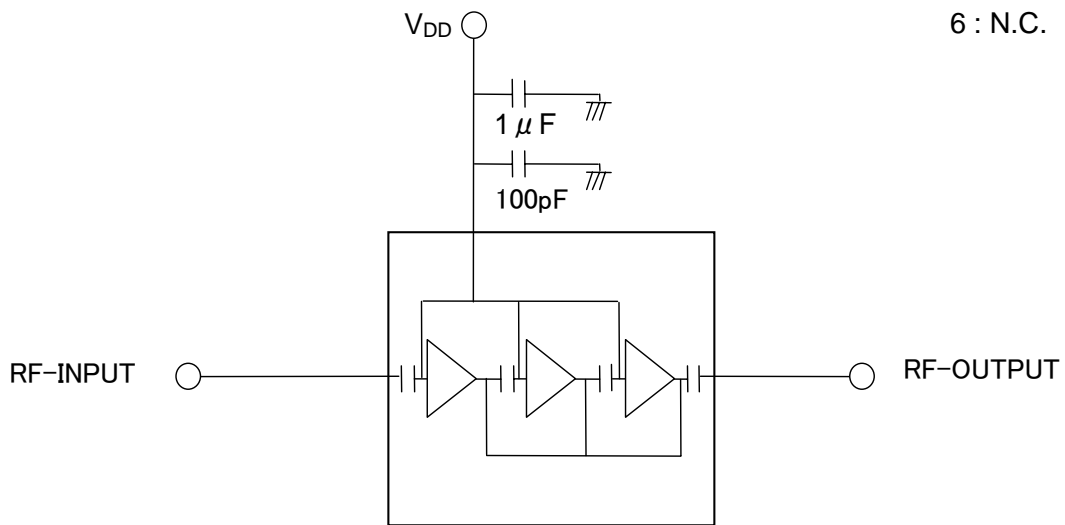

Note) : The capacitors are recommended on the bias supply line, close to package, In order to prevent video oscillations which could damage the module

Recommended Foot Pattern Layout

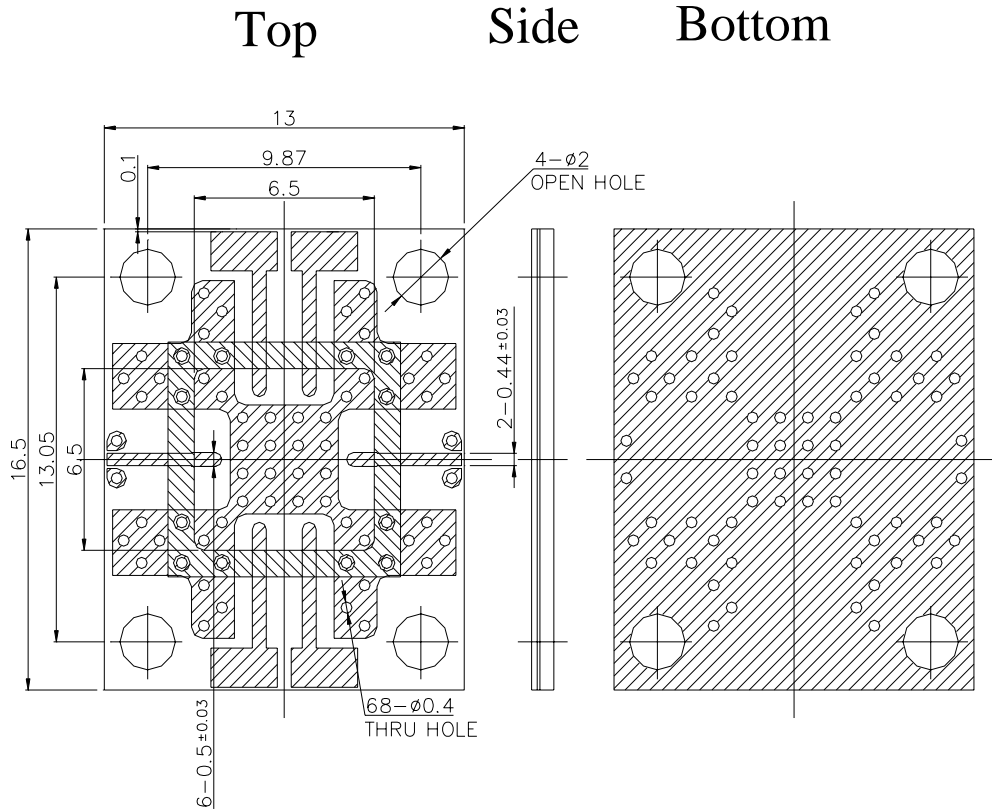

- NOTES.
- 1) .LAMINATE ; R04003 CORE THICKNESS $0.2 \pm 0.025\text{mm}$.
Cu FOIL THICKNESS 18 μm Typ.
 - 2) . ; PATTARN AND METAL PLACE
 - 3) . ; RESIST
 - 4) .FINISH ; Ni 1 μm MIN./Au 0.1 μm NOM.
 - 5) .GENERAL PATTARN TOLLERRANCE ; $\pm 0.05\text{mm}$

Cross Section

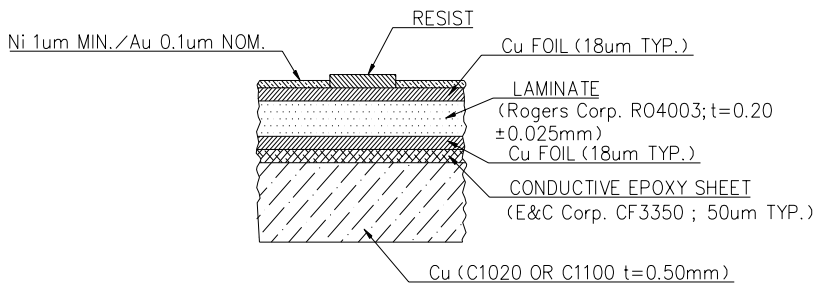

Recommended Stencil Pattern

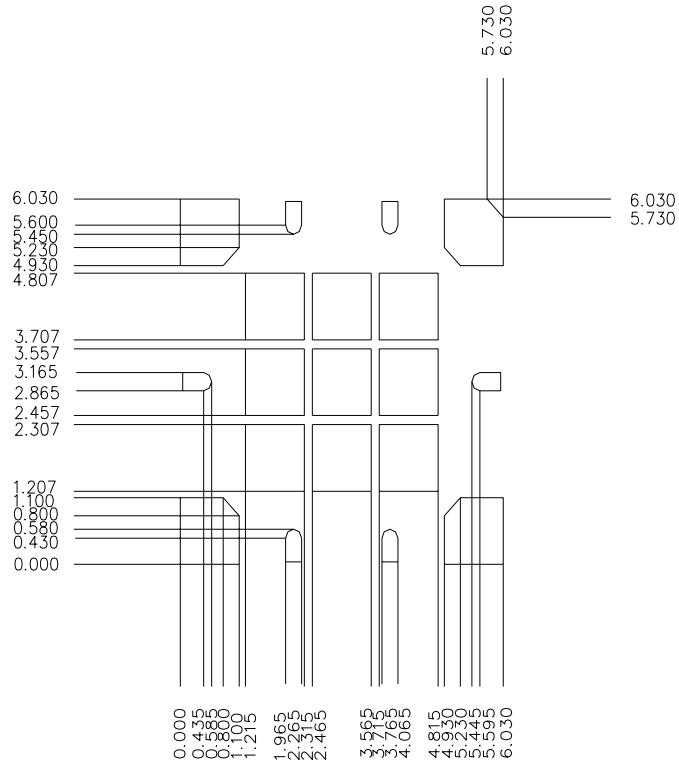

* thickness : 0.1mm

■ 4-inch Tray Packing (Part No. : FMM5703YC)

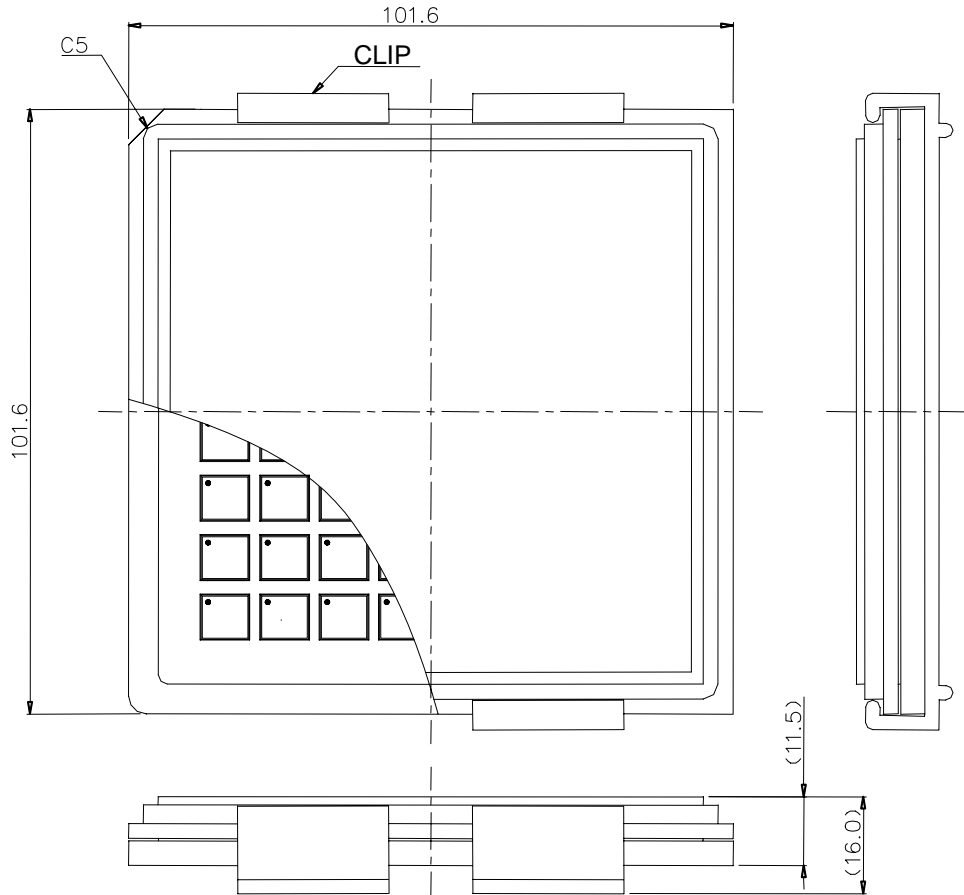

(unit in mm)

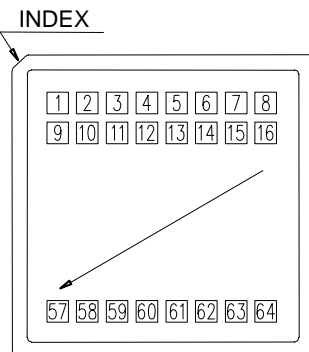

- (1) Maximum Quantity : 64pcs./Tray
- (2) Tray Material : Conductive PPE
- (3) Clip Material : Conductive PP

■ Tape and Reel Packing (Part No. : FMM5703YCT)

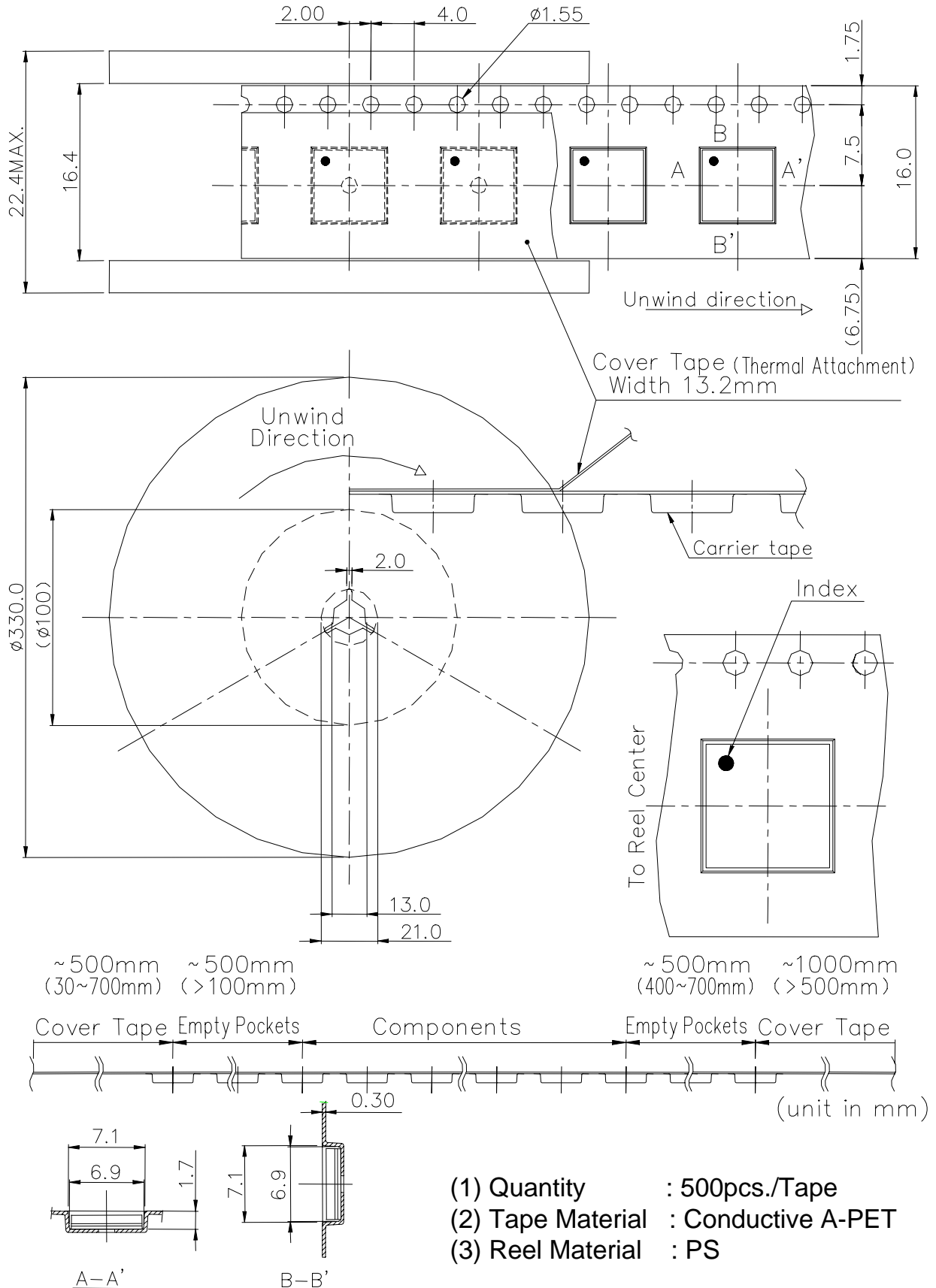

■ Mounting Method of SMD(Surface Mount Devices) for Lead-free Solder

Mounting Condition

- (1) For soldering, Lead-free solder (Sn-3.0Ag-0.5Cu)*¹ or equivalent shall be used.
(*1: The figure displays with weight %. A predominantly tin-rich alloy with 3.0% silver and 0.5% copper.)
- (2) A rosin type flux with a chlorine content of 0.2% or less shall be used. The rosin flux with low halogen content is recommended.
- (3) When soldering, use one of the following time / temperature methods for acceptable solder joints. Make sure the devices have been properly prepared with flux prior soldering.

* Reflow soldering method (Infrared reflow / Heat circulation reflow / Hot plate reflow):

Limit solder to 3 reflow cycles because resin is used in the modules manufacturing process. Excessive reflow cycles will effect the resin resulting in a potential failure or latent defect. The recommended reflow temperature profile is shown below. The temperature of the reflow profile must be measured at the device lead.

Reflow temperature profile and condition:

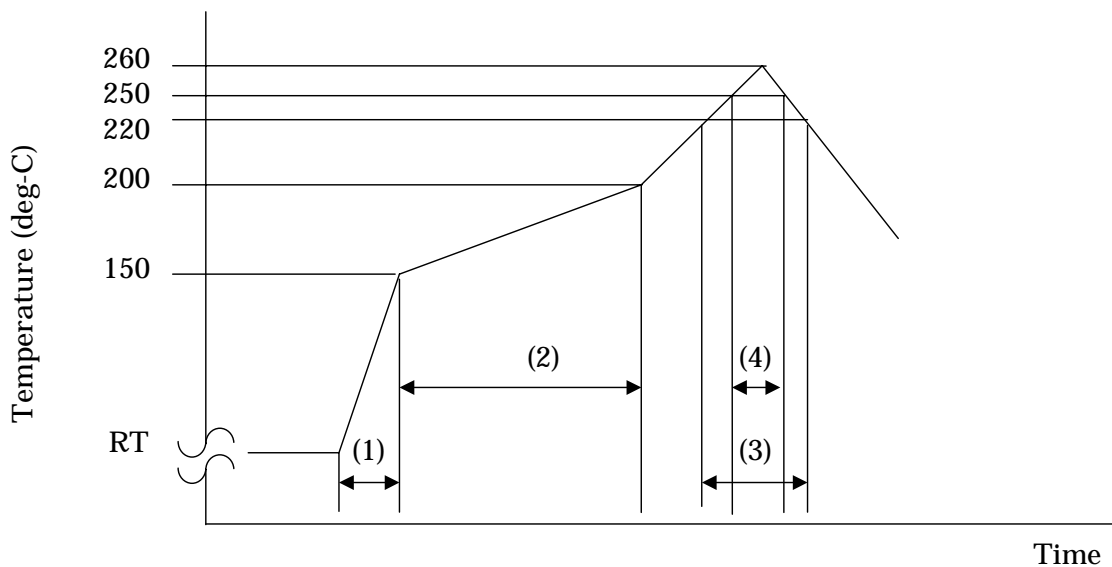

- | | |
|-----------------------|--|
| (1) Temperature rise: | 3deg-C /seconds. |
| (2) Preheating: | 150 – 200deg-C, 60 – 180 seconds. |
| (3) Main heating: | 220deg-C, 60 seconds max... |
| (4) Main heating: | 260deg-C max. more than 250deg-C, 10 seconds max.. |
- * Measurement point: Device lead.

- (4) The above-recommended conditions were confirmed using the manufacture's equipment and materials. However, when soldering these products, the soldering condition should be verified by customer using their equipment and materials.

■ Moisture Sensitivity levels(MSL)

* Floor life

Table 1. Moisture classification level and floor life

Level	Floor life(*1)	
	Time	Condition
1	Unlimited	=<30 degC / 85%RH
2	1year	=<30 degC / 60%RH
2a	4weeks	=<30 degC / 60%RH
3	168hours	=<30 degC / 60%RH
4	72hours	=<30 degC / 60%RH
5	48hours	=<30 degC / 60%RH
5a	24hours	=<30 degC / 60%RH
6	<24hours (*2)	=<30 degC / 60%RH

*1 Floor life means the maximum time allowed between open the bag and mounting reflow at the customer's factory.

*2 Device classified as level 6 must be dried by baking, then reflowed within the time limit specified each device.

Table 1 is an extract from IPC/JEDEC J-STD-020B.

* MSL of device

Package Type	MSL
YC, YD, YE, YF	3

If storage time, temperature or humidity condition is exceeded for floor life, please bake the device.
Baking condition : 125degC, 24hours

■ Humidity Lifetime for LNA MMIC

The following graph shows the lifetime of moisture resistance for the **LNA MMIC**. Each line in graph indicates the lifetime that is the estimated for the failure rate of **0.1% at 10 years** (Confidential Level = 90 %) and calculated from the results of pressure cooker (autoclave) bias test. A horizontal-axis shows typical ambient temperature. A vertical-axis shows relative humidity. The left side of the area delimited in each line indicates more than 10 years of lifetime. The Case-2 condition is around 15 times longer than the Case-1 condition.

Representative of device type : _____ FET

Test condition : _____ 120deg.C,85% RH

Bias condition : Case-1: VDS = 3V, VGS = -1V

Case-2: VDS = 3V, VGS = 0V

The field environmental conditions for a lifetime of 10 years (0.1% F.R , C.L.90%)

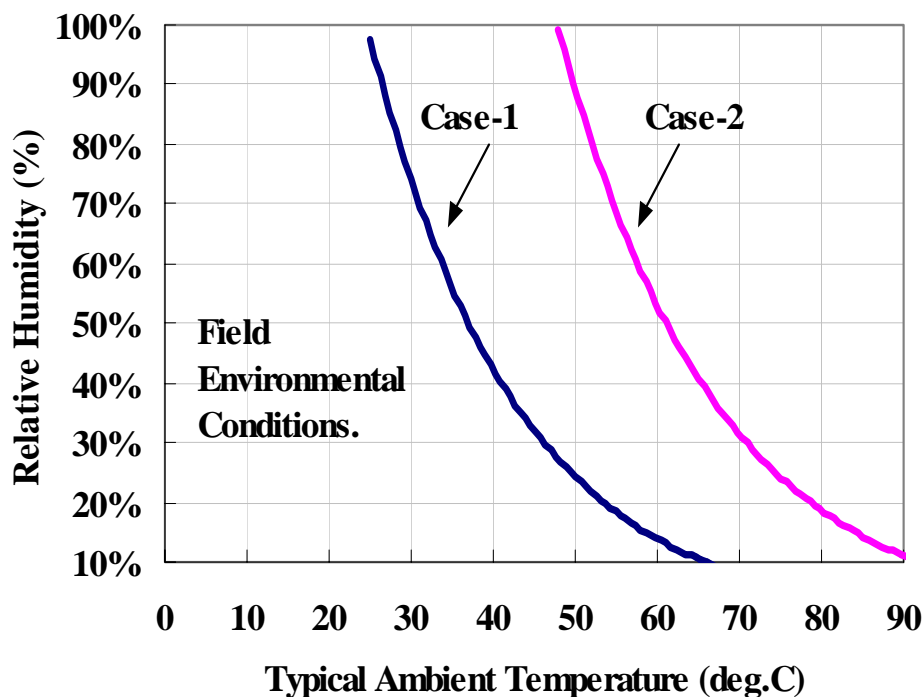

Field environmental conditions for operation

In case of that **LNA MMIC** is mounted to non-hermetic package, the following things will be considered.

Note 1. SEDI recommends our customers to use **LNA MMIC** within the left side area separating by a line in the graph.

Note 2. LNA MMIC under the environment conditions of no dew condensation.



For further information please contact :

**Sumitomo Electric Device Innovations,
U.S.A., Inc.**

2355 Zanker Rd.
San Jose, CA 95131-1138, U.S.A.
TEL: +1 408 232-9500
FAX: +1 408 428-9111

Sumitomo Electric Europe Ltd.

220 Centennial Park,
Elstree WD6 3SL United Kingdom
TEL: +44 (0)20 89538118
FAX: +44 (0)20 89538228

Sumitomo Electric Europe Ltd. (Italy Branch)

Piazza Don E. Mapelli, 60 - 20099
Sesto San Giovanni, Milano - Italy
TEL: +39-02-496386-01
FAX: +39-02-496386-25

Sumitomo Electric Asia, Ltd.

Room 2624-2637, 26/F.,
Sun Hung Kai Centre,
30 Harbour Road, Wanchai,
Hong Kong
TEL: +852-2576-0080
FAX: +852-2576-6412

Sumitomo Electric Device Innovations, Inc.

1000 Kamisukiahara, showa-cho
Nakakomagun, Yamanashi
409-3883, Japan
(Kokubo Industrial Park)
TEL +81-55-275-4411
FAX +81-55-275-9461

Sumitomo Electric Industries, Ltd.

Head Office (Tokyo)
3-9-1, Shibaura, Minato-ku, Tokyo 108-8539,
Japan
TEL +81-3-6722-3283
FAX +81-3-6722-3284

CAUTION

Sumitomo Electric Device Innovations, Inc. products contain **gallium arsenide (GaAs)** which can be hazardous to the human body and the environment. For safety, observe the following procedures:

- Do not put these products into the mouth.
- Do not alter the form of this product into a gas, powder, or liquid through burning, crushing, or chemical processing as these by-products are dangerous to the human body if inhaled, ingested, or swallowed.
- Observe government laws and company regulations when discarding this product. This product must be discarded in accordance with methods specified by applicable hazardous waste procedures.

Sumitomo Electric Device Innovations, Inc. reserves the right to change products and specifications without notice. The information does not convey any license under rights of Sumitomo Electric Device Innovations, Inc. or others.

© 2009 Sumitomo Electric Device Innovations, Inc.

