

### FEATURES

- High Output Power:  $P_{1dB}=35.5dBm$  (Typ.)
- High Gain:  $G_{1dB}=12.5dB$  (Typ.)
- High PAE:  $\eta_{add}=46%$  (Typ.)
- Hermetic Metal/Ceramic (SMT) Package
- Tape and Reel Available

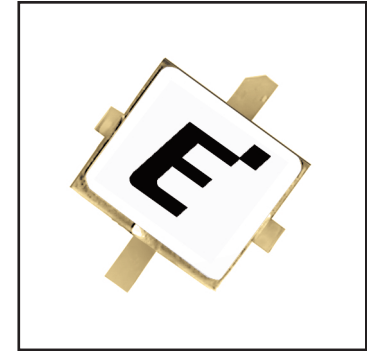

### DESCRIPTION

The FLU35XM is a GaAs FET designed for base station applications in the PCN/PCS frequency range. This is a new product series that uses a surface mount package that has been optimized for high volume cost driven applications.

Eudyna's stringent Quality Assurance Program assures the highest reliability and consistent performance.

### ABSOLUTE MAXIMUM RATINGS (Ambient Temperature $T_a=25^\circ C$ )

Item	Symbol	Condition	Rating	Unit
Drain-Source Voltage	$V_{DS}$		15	V
Gate-Source Voltage	$V_{GS}$		-5	V
Total Power Dissipation	PT	$T_c = 25^\circ C$	15	W
Storage Temperature	$T_{stg}$		-65 to +175	$^\circ C$
Channel Temperature	$T_{ch}$		+175	$^\circ C$

Eudyna recommends the following conditions for the reliable operation of GaAs FETs:

1. The drain - source operating voltage ( $V_{DS}$ ) should not exceed 10 volts.
2. The forward and reverse gate currents should not exceed 19.4 and -2.0 mA respectively with gate resistance of 100 $\Omega$ .
3. The operating channel temperature ( $T_{ch}$ ) should not exceed 145 $^\circ C$ .

### ELECTRICAL CHARACTERISTICS (Ambient Temperature $T_a=25^\circ C$ )

Item	Symbol	Conditions	Limits			Unit
			Min.	Typ.	Max.	
Drain Current	$I_{DSS}$	$V_{DS} = 5V, V_{GS} = 0V$	-	1200	1800	mA
Transconductance	gm	$V_{DS} = 5V, I_{DS} = 800mA$	-	600	-	mS
Pinch-Off Voltage	$V_p$	$V_{DS} = 5V, I_{DS} = 60mA$	-1.0	-2.0	-3.5	V
Gate-Source Breakdown Voltage	$V_{GSO}$	$I_{GS} = -60\mu A$	-5	-	-	V
Output Power at 1 dB G.C.P.	$P_{1dB}$	$V_{DS} = 10V$ $f = 2.0 GHz$ $I_{DS} = 0.6I_{DSS}$	34.5	35.5	-	dBm
Power Gain at 1 dB G.C.P.	$G_{1dB}$		11.5	12.5	-	dB
Power Added Efficiency	$\eta_{add}$		-	46	-	%
Thermal Resistance	$R_{th}$	Channel to Case	-	7.5	10	$^\circ C/W$

Case Style: XM

G.C.P.: Gain Compression Point

Note: The RF parameters are measured on a lot basis by sample testing at an AQL = 0.1%, Level-II inspection. Any lot failure shall be 100% retested.

# FLU35XM

## L-Band Medium & High Power GaAs FET

POWER DERATING CURVE

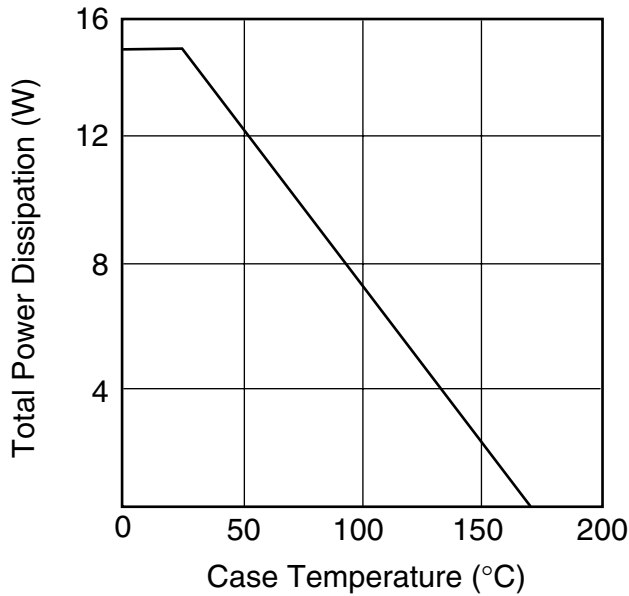

DRAIN CURRENT vs. DRAIN-SOURCE VOLTAGE

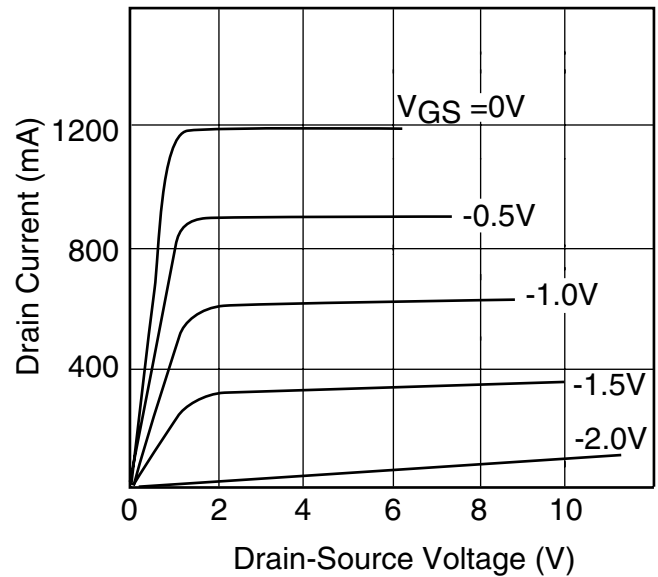

OUTPUT POWER vs. INPUT POWER

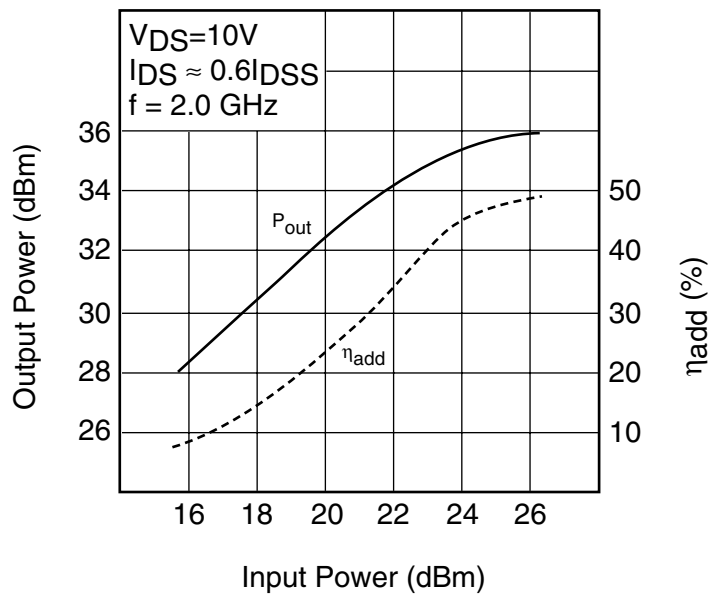

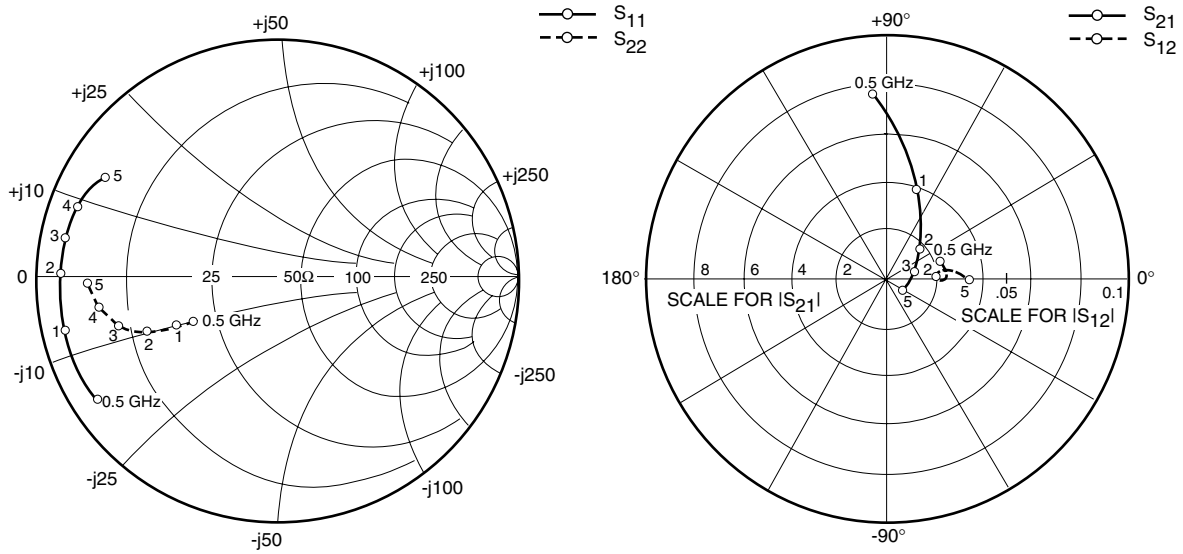

### S-PARAMETERS

$V_{DS} = 10V, I_{DS} = 720mA$

FREQUENCY (MHZ)	S11		S21		S12		S22	
	MAG	ANG	MAG	ANG	MAG	ANG	MAG	ANG
100	.957	-66.2	22.578	145.6	.014	60.6	.186	-125.7
500	.894	-147.0	7.757	94.1	.023	17.4	.386	-154.8
1000	.902	-167.1	3.947	71.6	.023	5.2	.455	-157.0
1500	.899	-176.1	2.592	55.8	.023	1.5	.517	-157.1
2000	.897	177.8	1.897	41.9	.022	-1.0	.578	-158.9
2500	.896	172.9	1.492	29.5	.021	3.9	.634	-161.3
3000	.892	168.1	1.223	17.9	.022	1.5	.679	-164.7
3500	.883	163.4	1.041	7.0	.023	.3	.714	-168.0
4000	.871	158.6	.921	-3.9	.026	5.3	.742	-171.7
4500	.858	153.9	.839	-14.8	.029	2.9	.766	-175.4
5000	.830	148.8	.790	-26.5	.034	-1.0	.786	-179.4

# FLU35XM

## L-Band Medium & High Power GaAs FET

### Case Style "XM" Metal-Ceramic Hermetic Package

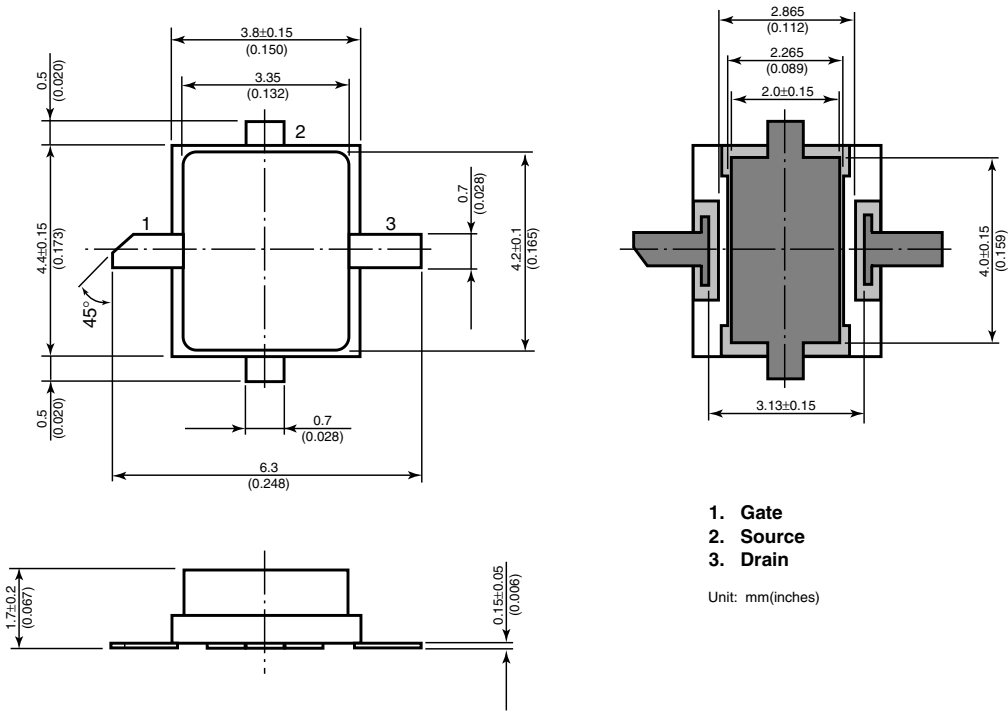

For further information please contact:

#### Eudyna Devices USA Inc.

2355 Zanker Rd.  
San Jose, CA 95131-1138, U.S.A.  
TEL: (408) 232-9500  
FAX: (408) 428-9111  
[www.us.eudyna.com](http://www.us.eudyna.com)

#### Eudyna Devices Europe Ltd.

Network House  
Norreys Drive  
Maidenhead, Berkshire SL6 4FJ  
United Kingdom  
TEL: +44 (0) 1628 504800  
FAX: +44 (0) 1628 504888

#### Eudyna Devices Asia Pte Ltd.

Hong Kong Branch  
Rm. 1101, Ocean Centre, 5 Canton Rd.  
Tsim Sha Tsui, Kowloon, Hong Kong  
TEL: +852-2377-0227  
FAX: +852-2377-3921

#### Eudyna Devices Inc.

Sales Division  
1, Kanai-cho, Sakae-ku  
Yokohama, 244-0845, Japan  
TEL: +81-45-853-8156  
FAX: +81-45-853-8170

#### CAUTION

Eudyna Devices Inc. products contain **gallium arsenide (GaAs)** which can be hazardous to the human body and the environment. For safety, observe the following procedures:

- Do not put this product into the mouth.
- Do not alter the form of this product into a gas, powder, or liquid through burning, crushing, or chemical processing as these by-products are dangerous to the human body if inhaled, ingested, or swallowed.
- Observe government laws and company regulations when discarding this product. This product must be discarded in accordance with methods specified by applicable hazardous waste procedures.

Eudyna Devices Inc. reserves the right to change products and specifications without notice. The information does not convey any license under rights of Eudyna Devices Inc. or others.

© 2004 Eudyna Devices USA Inc.  
Printed in U.S.A.

# Eudyna