

FLM8596-15F

X-Band Internally Matched FET

FEATURES

- High Output Power: P_{1dB}=42.0dBm(Typ.)
- High Gain: G_{1dB}=7.5dB(Typ.)
- High PAE: η_{add}=32%(Typ.)
- Broad Band: 8.5~9.6GHz
- Impedance Matched Z_{in}/Z_{out} = 50Ω
- Hermetically Sealed Package



DESCRIPTION

The FLM8596-15F is a power GaAs FET that is internally matched for standard communication bands to provide optimum power and gain in a 50Ω system.

ABSOLUTE MAXIMUM RATINGS (Case Temperature T_c=25°C)

Item	Symbol	Rating	Unit
Drain-Source Voltage	V _{DS}	15	V
Gate-Source Voltage	V _{GS}	-5	V
Total Power Dissipation	P _T	57.7	W
Storage Temperature	T _{stg}	-65 to +175	°C
Channel Temperature	T _{ch}	175	°C

Recommended Operating Condition(Case Temperature T_c=25°C)

Item	Symbol	Condition	Limit	Unit
DC Input Voltage	V _{DS}		≤10	V
Gate Current	I _{GS}	R _G =50Ω	≤16.7	mA
Gate Current	I _{GR}	R _G =50Ω	≥-3.62	mA

ELECTRICAL CHARACTERISTICS (Case Temperature T_c=25°C)

Item	Symbol	Test Conditions	Limit			Unit
			Min.	Typ.	Max.	
Drain Current	I _{DSS}	V _{DS} =5V, V _{GS} =0V	-	7.2	10.8	A
Transconductance	g _m	V _{DS} =5V, I _{DS} =2.4A	-	4500	-	mS
Pinch-off Voltage	V _p	V _{DS} =5V, I _{DS} =240mA	-0.5	-1.5	-3.0	V
Gate-Source Breakdown Voltage	V _{GSO}	I _{GS} =-300μA	-5.0	-	-	V
Output Power at 1dB G.C.P.	P _{1dB}	V _{DS} =10V f=8.5 - 9.6 GHz I _{DS} =0.5I _{DSS} Z _S =Z _L =50Ω	41.0	42.0	-	dBm
Power Gain at 1dB G.C.P.	G _{1dB}		6.5	7.5	-	dB
Drain Current	I _{DSr}		-	4.0	5.0	A
Power-added Efficiency	η _{add}		-	32	-	%
Gain Flatness	ΔG		-	-	1.2	dB
Thermal Resistance	R _{th}	Channel to Case	-	2.3	2.6	°C/W
Channel Temperature Rise	ΔT _{ch}	10V X I _{DSr} X R _{th}	-	-	100	°C

CASE STYLE: IB

G.C.P.:Gain Compression Point

ESD	Class III	2000V ~
-----	-----------	---------

Note : Based on EIAJ ED-4701 C-111A(C=100pF, R=1.5kΩ)

FLM8596-15F

X-Band Internally Matched FET

POWER DERATING CURVE

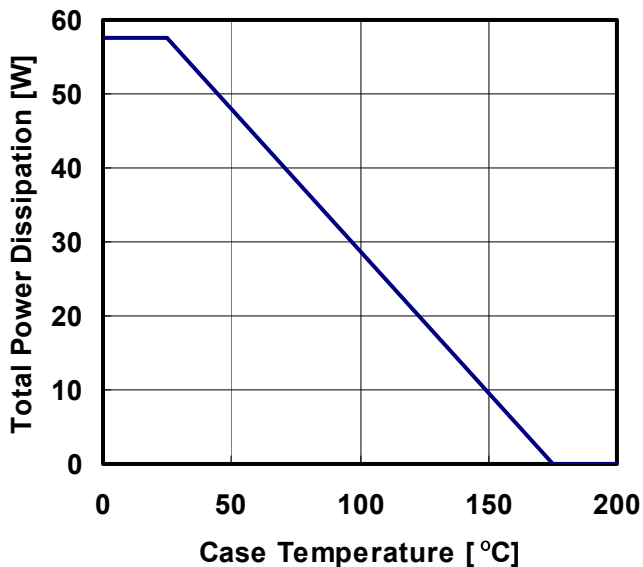

OUTPUT POWER & POWER ADDED EFFICIENCY vs. INPUT POWER

V_{ds}=10V, I_{ds}=0.5I_{dss}, f=9.05GHz

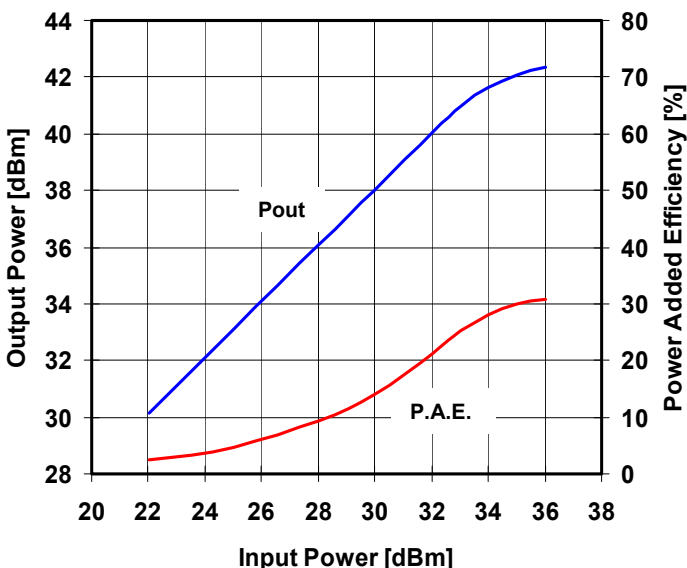

OUTPUT POWER vs. FREQUENCY

V_{ds}=10V, I_{ds}=0.5I_{dss}

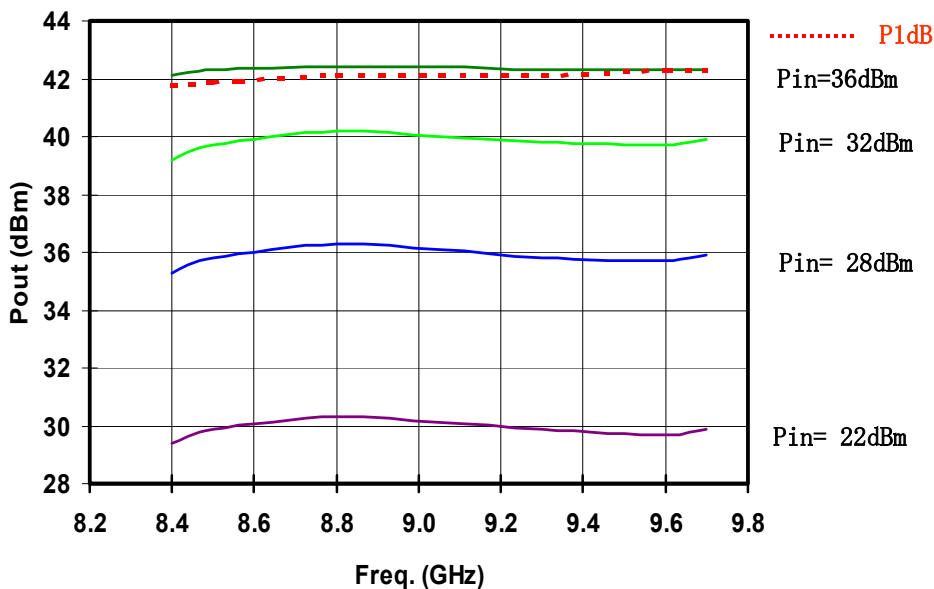

FLM8596-15F

X-Band Internally Matched FET

■ S-PARAMETER

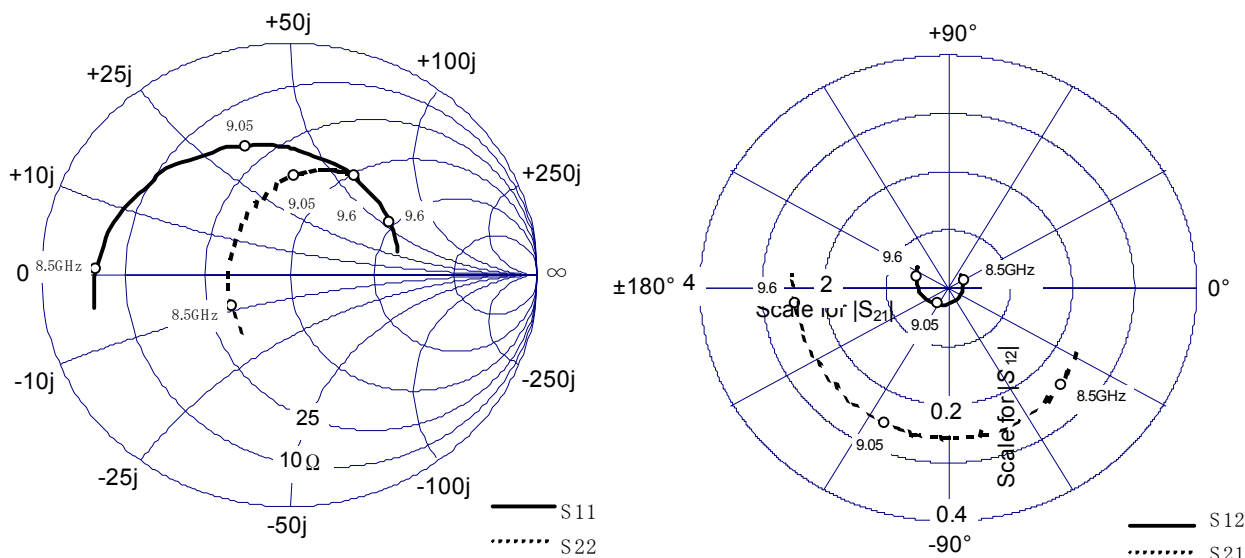

VDS=10V, IDS=0.5Idss

Freq. GHz	S11		S21		S12		S22	
	Mag	Ang	Mag	Ang	Mag	Ang	Mag	Ang
8.4	0.795	-169.9	2.386	-29.6	0.031	47.6	0.318	-127.4
8.5	0.777	178.3	2.459	-42.2	0.029	29.9	0.268	-149.3
8.6	0.753	165.8	2.524	-55.9	0.024	5.6	0.244	-177.6
8.7	0.718	154.1	2.582	-69.0	0.024	-28.6	0.257	151.5
8.8	0.682	140.5	2.583	-81.7	0.024	-55.5	0.298	126.6
8.9	0.639	128.7	2.562	-94.6	0.027	-85.8	0.354	107.8
9.0	0.612	114.7	2.544	-106.6	0.031	-108.8	0.402	93.8
9.1	0.569	101.1	2.530	-118.4	0.035	-132.1	0.439	83.6
9.2	0.545	87.9	2.503	-129.6	0.039	-149.9	0.467	75.2
9.3	0.514	73.5	2.473	-141.1	0.044	-164.7	0.481	69.1
9.4	0.499	60.2	2.470	-151.8	0.048	-178.2	0.494	64.4
9.5	0.477	44.5	2.464	-162.7	0.051	168.8	0.500	60.7
9.6	0.461	29.5	2.485	-174.2	0.054	158.0	0.499	58.2
9.7	0.445	12.7	2.526	174.5	0.061	145.6	0.496	55.9

FLM8596-15F

X-Band Internally Matched FET

■ Package Out Line

CASE STYLE: IB

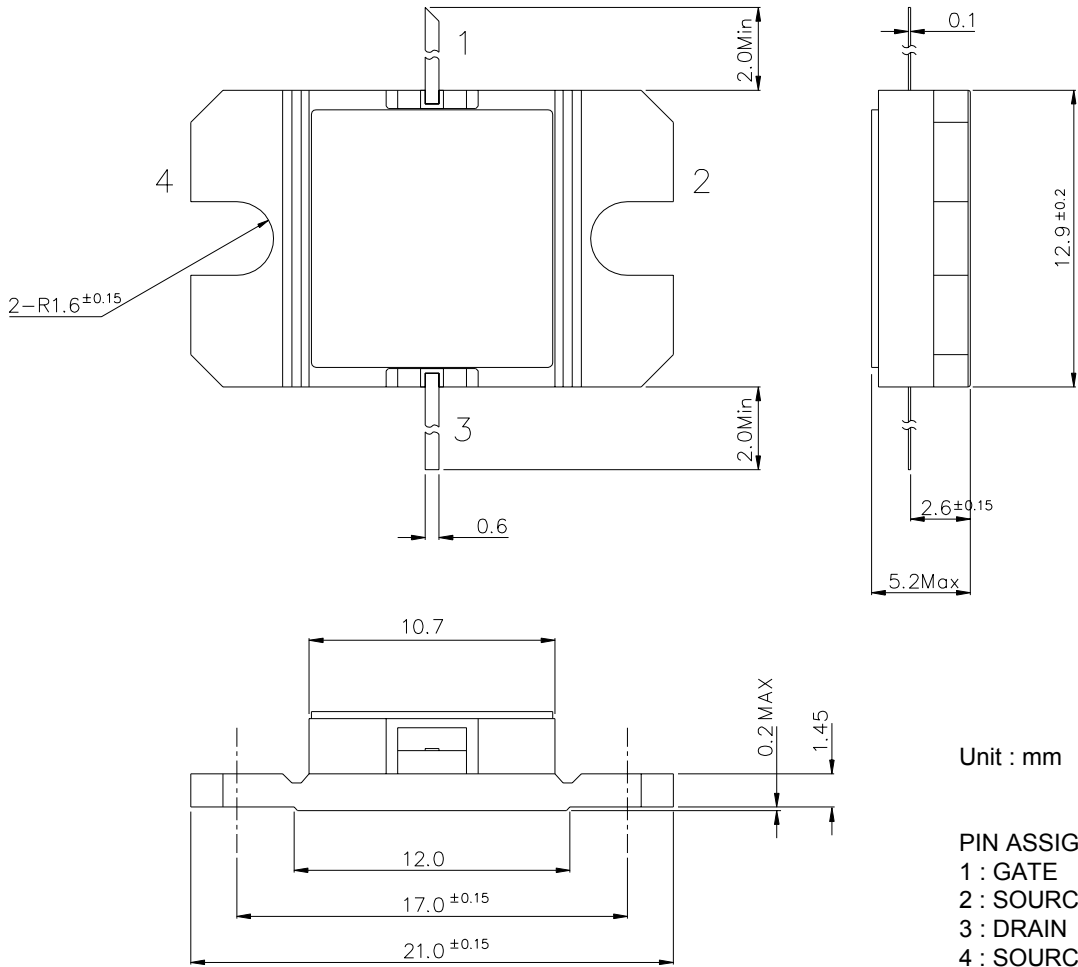

FLM8596-15F

X-Band Internally Matched FET

For further information please contact :

Eudyna Devices USA Inc.

2355 Zanker Rd.
San Jose, CA 95131-1138, U.S.A.
TEL: (408) 232-9500
FAX: (408) 428-9111
www.us.eudyna.com

Eudyna Devices Europe Ltd.

Network House
Norreys Drive
Maidenhead, Berkshire SL6 4FJ
United Kingdom
TEL: +44 (0) 1628 504800
FAX: +44 (0) 1628 504888

Eudyna Devices Asia Pte. Ltd.

Hong Kong Branch
Rm.1101, Ocean Centre, 5 Canton Road
Tsim Sha Tsui, Kowloon, Hong Kong
TEL: +852-2377-0227
FAX: +852-2377-3921

Eudyna Devices Inc.

1000 Kamisukiahara, showa-cho
Nakakomagun, Yamanashi
409-3883, Japan
(Kokubo Industrial Park)
TEL +81-55-275-4411
FAX +81-55-275-9461

Sales Division

1, Kanai-cho, Sakae-ku
Yokohama, 244-0845, Japan
TEL +81-45-853-8156
FAX +81-45-853-8170

CAUTION

Eudyna Devices Inc. products contain **gallium arsenide (GaAs)** which can be hazardous to the human body and the environment. For safety, observe the following procedures:

- Do not put these products into the mouth.
- Do not alter the form of this product into a gas, powder, or liquid through burning, crushing, or chemical processing as these by-products are dangerous to the human body if inhaled, ingested, or swallowed.
- Observe government laws and company regulations when discarding this product. This product must be discarded in accordance with methods specified by applicable hazardous waste procedures.

Eudyna Devices Inc. reserves the right to change products and specifications without notice. The information does not convey any license under rights of Eudyna Devices Inc. or others.

© 2004 Eudyna Devices USA Inc.
Printed in U.S.A.