

FEATURES

- High Output Power: $P_{1dB} = 43.0\text{dBm}$ (Typ.)
- High Gain: $G_{1dB} = 11.0\text{dB}$ (Typ.)
- High PAE: $\eta_{add} = 38\%$ (Typ.)
- Broad Band: 2.5 ~ 2.7GHz
- Impedance Matched $Z_{in}/Z_{out} = 50\Omega$
- Hermetically Sealed Package

DESCRIPTION

The FLM2527L-20F is a power GaAs FET that is internally matched for standard communication bands to provide optimum power and gain in a 50 ohm system. This product is uniquely suited for use in MMDS base station amplifiers applications.

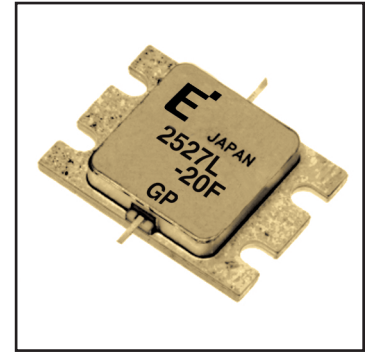

Eudyna's stringent Quality Assurance Program assures the highest reliability and consistent performance.

ABSOLUTE MAXIMUM RATING (Ambient Temperature $T_a=25^\circ\text{C}$)

Item	Symbol	Condition	Rating	Unit
Drain-Source Voltage	V_{DS}		15	V
Gate-Source Voltage	V_{GS}		-5	V
Total Power Dissipation	P_T	$T_C = 25^\circ\text{C}$	83.3	W
Storage Temperature	T_{stg}		-65 to +175	$^\circ\text{C}$
Channel Temperature	T_{ch}		175	$^\circ\text{C}$

Eudyna recommends the following conditions for the reliable operation of GaAs FETs:

1. The drain-source operating voltage (V_{DS}) should not exceed 10 volts.
2. The forward and reverse gate currents should not exceed 26.0 and -11.6 mA respectively with gate resistance of 25 Ω .

ELECTRICAL CHARACTERISTICS (Ambient Temperature $T_a=25^\circ\text{C}$)

Item	Symbol	Test Conditions	Limit			Unit	
			Min.	Typ.	Max.		
Saturated Drain Current	I_{DSS}	$V_{DS} = 5\text{V}, V_{GS} = 0\text{V}$	-	9.0	13.5	A	
Transconductance	g_m	$V_{DS} = 5\text{V}, I_{DS} = 4800\text{mA}$	-	4000	-	mS	
Pinch-off Voltage	V_p	$V_{DS} = 5\text{V}, I_{DS} = 480\text{mA}$	-1.0	-2.0	-3.5	V	
Gate Source Breakdown Voltage	V_{GSO}	$I_{GS} = -480\mu\text{A}$	-5.0	-	-	V	
Output Power at 1dB G.C.P.	P_{1dB}	$V_{DS} = 10\text{V},$ $I_{DS} = 0.55 I_{DSS}$ (Typ.), $f = 2.5 \sim 2.7 \text{GHz},$ $Z_S = Z_L = 50 \text{ohm}$	42.0	43.0	-	dBm	
Power Gain at 1dB G.C.P.	G_{1dB}		10.0	11.0	-	dB	
Drain Current	I_{dsr}		-	4800	6000	mA	
Power-added Efficiency	η_{add}		-	38	-	%	
Gain Flatness	ΔG		-	-	± 0.6	dB	
Thermal Resistance	R_{th}		Channel to Case	-	1.6	1.8	$^\circ\text{C}/\text{W}$
Channel Temperature Rise	ΔT_{ch}		$10\text{V} \times I_{dsr} \times R_{th}$	-	-	80	$^\circ\text{C}$

CASE STYLE: IK

G.C.P.: Gain Compression Point

FLM2527L-20F

L-Band Internally Matched FET

POWER DERATING CURVE

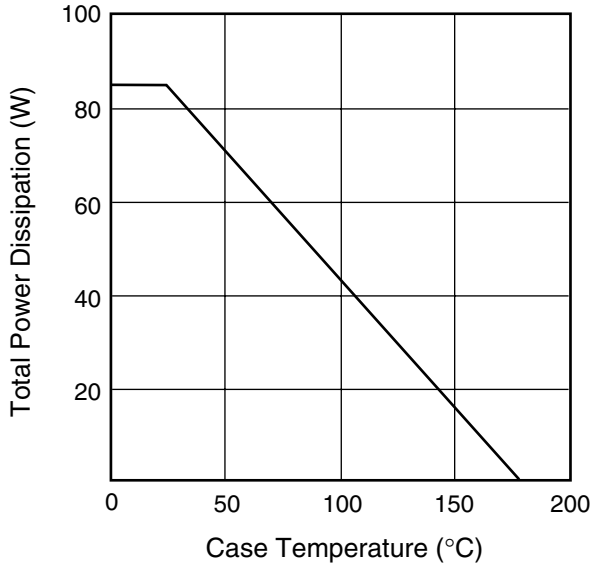

OUTPUT POWER vs. INPUT POWER

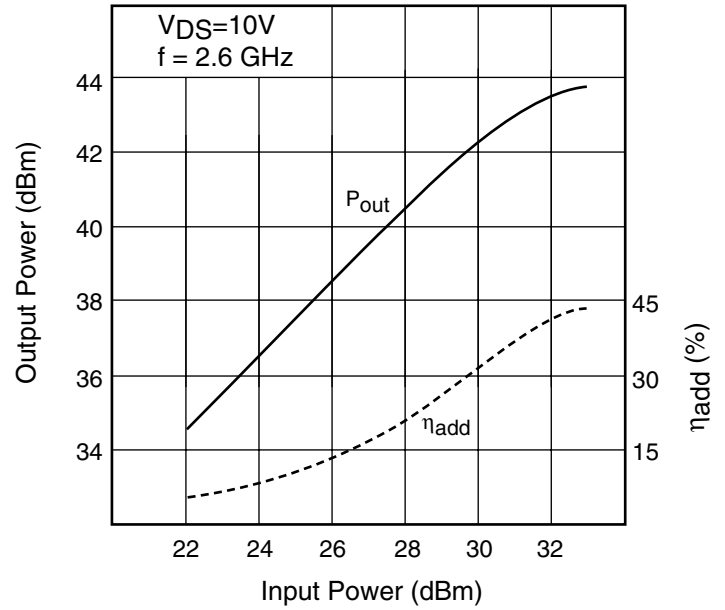

OUTPUT POWER vs. FREQUENCY

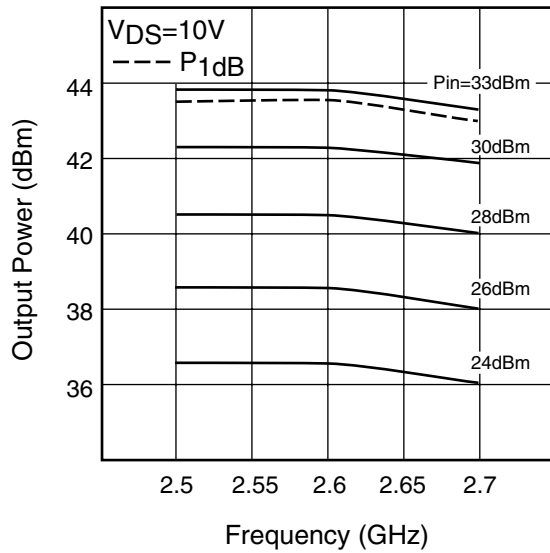

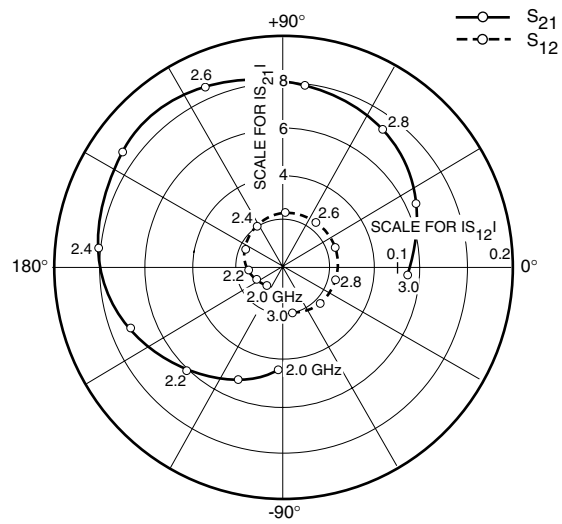
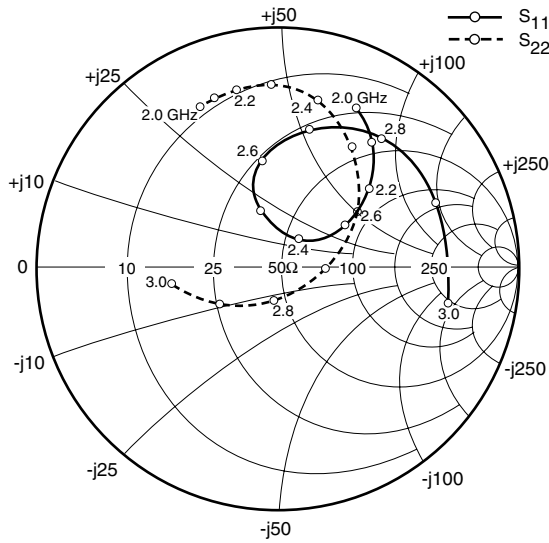

S-PARAMETERS

$V_{DS} = 10V, I_{DS} = 4800mA$

FREQUENCY (MHZ)	S11		S21		S12		S22	
	MAG	ANG	MAG	ANG	MAG	ANG	MAG	ANG
2000	.732	64.2	2.176	-93.6	.022	-129.8	.746	115.8
2100	.641	52.9	2.582	-112.2	.025	-153.8	.756	110.7
2200	.503	40.8	3.060	-133.5	.030	-175.9	.768	103.0
2300	.323	32.4	3.584	-158.6	.036	155.0	.763	92.1
2400	.151	55.5	4.026	173.6	.041	122.8	.711	76.9
2500	.247	105.8	4.264	144.5	.046	88.9	.591	58.7
2600	.444	98.0	4.245	113.6	.047	53.1	.404	35.3
2700	.595	77.1	4.001	83.4	.048	20.1	.200	-0.9
2800	.677	51.7	3.626	54.2	.046	-14.1	.134	-96.6
2900	.707	22.6	3.189	25.6	.046	-44.5	.286	-149.4
3000	.715	-11.5	2.725	-2.8	.041	-76.9	.441	-171.5

FLM2527L-20F

L-Band Internally Matched FET

Case Style "IK"

Metal-Ceramic Hermetic Package

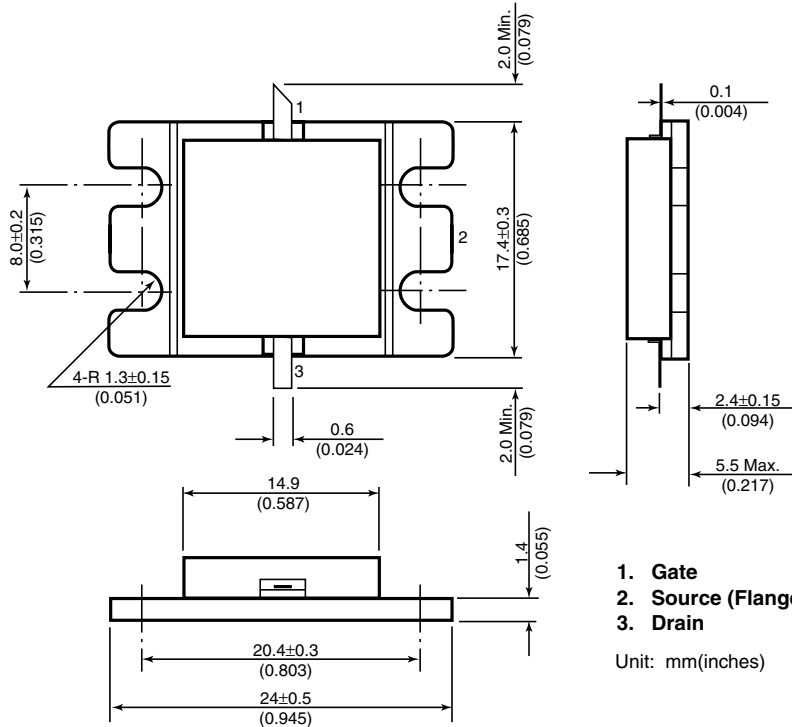

For further information please contact:

Eudyna Devices USA Inc.

2355 Zanker Rd.
San Jose, CA 95131-1138, U.S.A.
TEL: (408) 232-9500
FAX: (408) 428-9111
www.us.eudyna.com

Eudyna Devices Europe Ltd.

Network House
Norreys Drive
Maidenhead, Berkshire SL6 4FJ
United Kingdom
TEL: +44 (0) 1628 504800
FAX: +44 (0) 1628 504888

Eudyna Devices Asia Pte Ltd.

Hong Kong Branch
Rm. 1101, Ocean Centre, 5 Canton Rd.
Tsim Sha Tsui, Kowloon, Hong Kong
TEL: +852-2377-0227
FAX: +852-2377-3921

Eudyna Devices Inc.

Sales Division
1, Kanai-cho, Sakae-ku
Yokohama, 244-0845, Japan
TEL: +81-45-853-8156
FAX: +81-45-853-8170

CAUTION

Eudyna Devices Inc. products contain **gallium arsenide (GaAs)** which can be hazardous to the human body and the environment. For safety, observe the following procedures:

- Do not put this product into the mouth.
- Do not alter the form of this product into a gas, powder, or liquid through burning, crushing, or chemical processing as these by-products are dangerous to the human body if inhaled, ingested, or swallowed.
- Observe government laws and company regulations when discarding this product. This product must be discarded in accordance with methods specified by applicable hazardous waste procedures.

Eudyna Devices Inc. reserves the right to change products and specifications without notice. The information does not convey any license under rights of Eudyna Devices Inc. or others.

© 2004 Eudyna Devices USA Inc.
Printed in U.S.A.

Eudyna