

# FLL200IB-1, FLL200IB-2, FLL200IB-3

## L-Band Medium & High Power GaAs FET

### FEATURES

- High Output Power:  $P_{1dB} = 42.5dBm$  (Typ.)
- High Gain:  $G_{1dB} = 13.0dB$  (Typ.)@ 1.8GHz (FLL200IB-1)
- High PAE:  $\eta_{add} = 34%$  (Typ.)
- Proven Reliability
- Hermetically Sealed Package

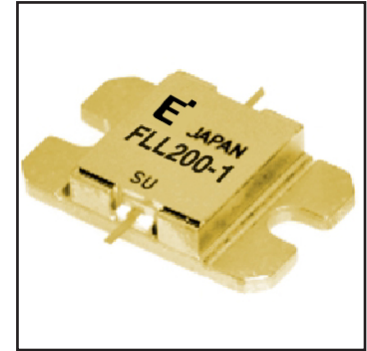

### DESCRIPTION

The FLL200IB-1, FLL200IB-2, FLL200IB-3 are Power GaAs FETs that are specifically designed to provide high power at L-Band frequencies with gain, linearity and efficiency superior to that of silicon devices. The performance in multitone environments for Class AB operation make them ideally suited for base station applications.

Eudyna stringent Quality Assurance Program assures the highest reliability and consistent performance.

### ABSOLUTE MAXIMUM RATING (Ambient Temperature $T_a=25^\circ C$ )

Item	Symbol	Condition	Rating	Unit
Drain-Source Voltage	$V_{DS}$		15	V
Gate-Source Voltage	$V_{GS}$		-5	V
Total Power Dissipation	$P_T$	$T_C = 25^\circ C$	83.3	W
Storage Temperature	$T_{stg}$		-65 to +175	$^\circ C$
Channel Temperature	$T_{ch}$		175	$^\circ C$

Eudyna recommends the following conditions for the reliable operation of GaAs FETs:

1. The drain-source operating voltage ( $V_{DS}$ ) should not exceed 10 volts.
2. The forward and reverse gate currents should not exceed 53.6 and -11.6 mA respectively with gate resistance of  $25\Omega$ .
3. The operating channel temperature ( $T_{ch}$ ) should not exceed  $145^\circ C$ .

### ELECTRICAL CHARACTERISTICS (Ambient Temperature $T_a=25^\circ C$ )

Item	Symbol	Test Conditions	Limit			Unit
			Min.	Typ.	Max.	
Saturated Drain Current	$I_{DSS}$	$V_{DS} = 5V, V_{GS} = 0V$	-	8	12	A
Transconductance	$g_m$	$V_{DS} = 5V, I_{DS} = 4800mA$	-	4000	-	mS
Pinch-off Voltage	$V_p$	$V_{DS} = 5V, I_{DS} = 480mA$	-1.0	-2.0	-3.5	V
Gate Source Breakdown Voltage	$V_{GSO}$	$I_{GS} = -480\mu A$	-5	-	-	V
Output Power at 1dB G.C.P.	FLL200IB-1	$V_{DS} = 10V$ $I_{DS} = 0.6 I_{DSS}$ (Typ.)	41.5	42.5	-	dBm
	FLL200IB-2					
	FLL200IB-3					
Power Gain at 1dB G.C.P.	FLL200IB-1	$V_{DS} = 10V$ $I_{DS} = 0.6 I_{DSS}$ (Typ.)	12.0	13.0	-	dB
	FLL200IB-2					
	FLL200IB-3					
Drain Current	$I_{dsr}$	$V_{DS} = 10V$	-	4.8	6.0	A
Power added Efficiency	$\eta_{add}$	$I_{DS} = 0.6 I_{DSS}$ (Typ.)	-	34	-	%
Thermal Resistance	$R_{th}$	Channel to Case	-	1.6	1.8	$^\circ C/W$
Channel Temperature Rise	$\Delta T_{ch}$	$10V \times I_{dsr} \times R_{th}$	-	-	80	$^\circ C$

CASE STYLE: IB

G.C.P.: Gain Compression Point

**Eudyna**

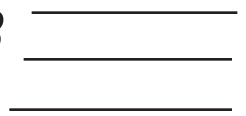

### POWER DERATING CURVE

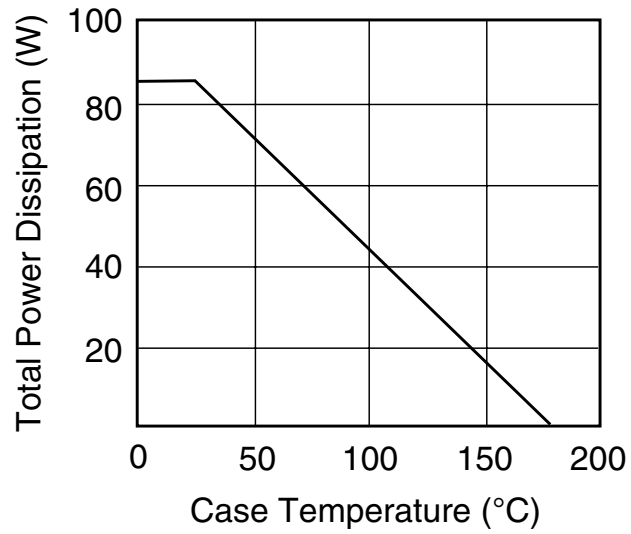

### DRAIN CURRENT vs. DRAIN-SOURCE VOLTAGE

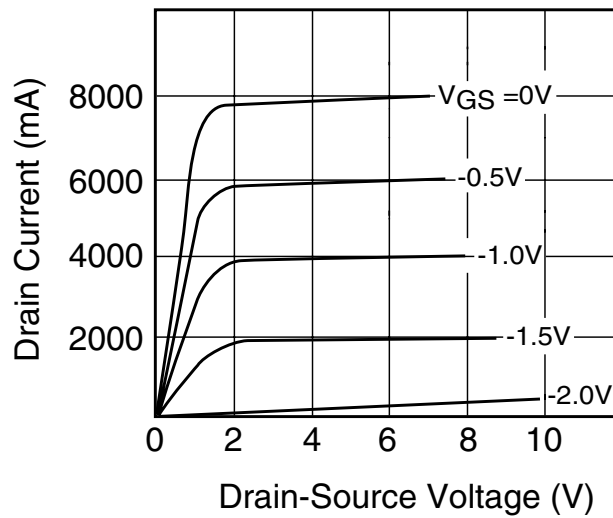

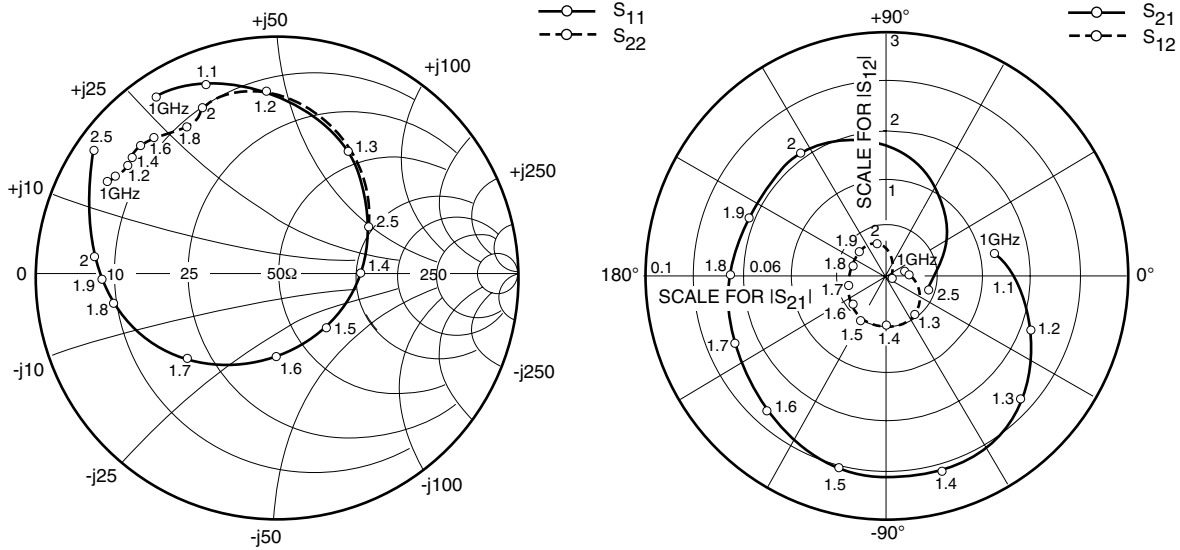

### S-PARAMETERS

$V_{DS} = 10V, I_{DS} = 4800mA$

FREQUENCY (MHZ)	S11		S21		S12		S22	
	MAG	ANG	MAG	ANG	MAG	ANG	MAG	ANG
1000	.888	124.3	1.517	13.5	.009	-5.0	.819	150.3
1100	.841	110.9	1.761	-2	.012	-17.3	.796	147.5
1200	.754	91.4	2.113	-18.0	.015	-33.3	.786	145.9
1300	.584	60.4	2.559	-42.4	.019	-56.8	.790	142.7
1400	.353	1.2	2.876	-73.3	.022	-86.9	.790	140.7
1500	.341	-87.7	2.754	-105.9	.021	-119.8	.800	136.5
1600	.490	-133.3	2.443	-132.5	.019	-147.5	.787	131.6
1700	.609	-156.4	2.215	-156.1	.017	-172.2	.764	127.5
1800	.680	-170.8	2.096	-179.2	.016	162.7	.732	123.4
1900	.719	179.5	2.034	155.9	.015	135.4	.716	121.2
2000	.753	173.8	1.953	126.8	.015	103.5	.729	116.4
2500	.942	145.3	.563	-15.5	.006	-39.0	.451	32.7

### OUTPUT POWER vs. INPUT POWER

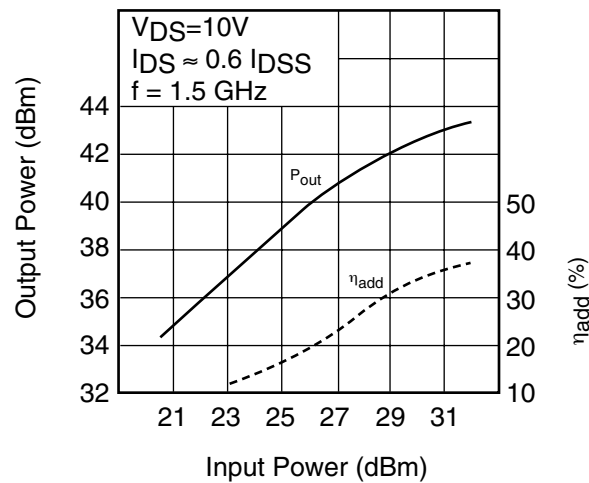

# FLL200IB-2

## L-Band Medium & High Power GaAs FET

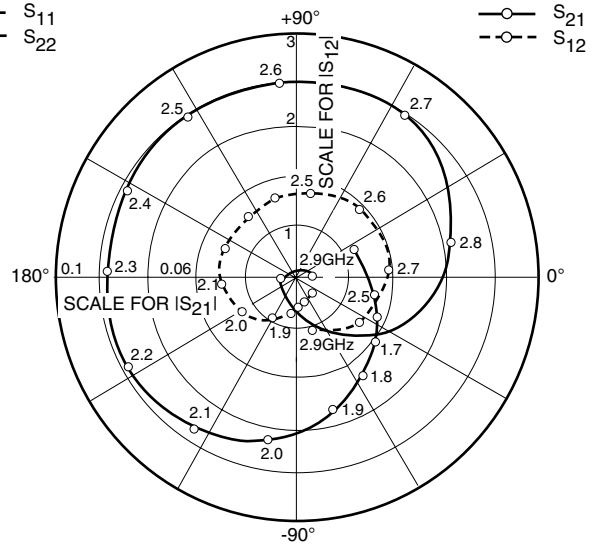
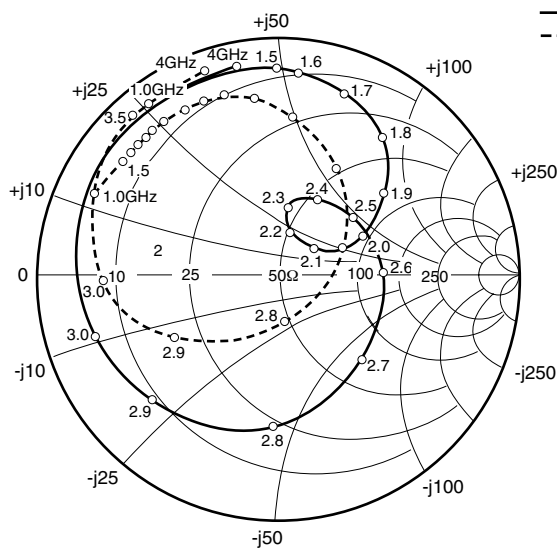

### S-PARAMETERS

$V_{DS} = 10V, I_{DS} = 4800mA$

FREQUENCY (MHZ)	S11		S21		S12		S22	
	MAG	ANG	MAG	ANG	MAG	ANG	MAG	ANG
500	.944	157.3	1.164	60.9	.004	-8	.906	166.1
1000	.937	127.4	.835	28.8	.006	-16.3	.855	153.8
1500	.880	90.3	1.090	-14.0	.010	-55.4	.826	141.4
1700	.791	68.9	1.421	-39.7	.014	-81.9	.810	135.6
2000	.379	27.8	2.283	-100.2	.025	-147.2	.814	125.6
2300	.309	82.4	2.569	179.4	.031	128.7	.789	104.9
2500	.408	41.8	2.632	128.5	.035	78.5	.651	83.8
2700	.480	-43.5	2.631	55.1	.039	6.2	.290	26.4
3000	.803	-158.4	.772	-68.4	.012	-111.1	.718	-177.7
3500	.915	135.8	.030	-151.4	.001	72.1	.937	131.5
4000	.926	102.3	.013	-8.2	.002	8.3	.947	109.9

### OUTPUT POWER vs. INPUT POWER

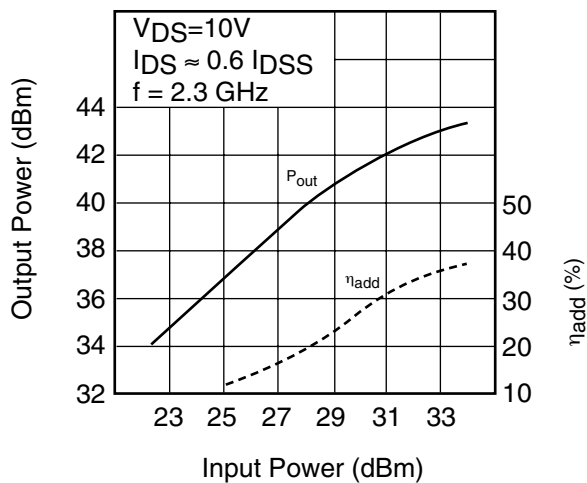

# FLL200IB-3

## L-Band Medium & High Power GaAs FET

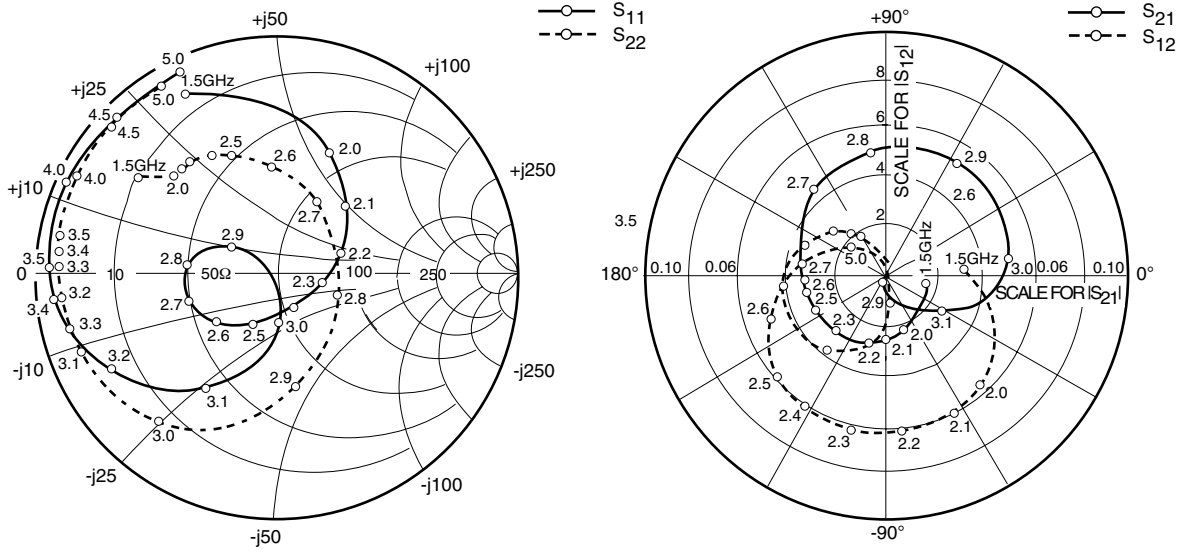

### S-PARAMETERS

$V_{DS} = 10V, I_{DS} = 4800mA$

FREQUENCY (MHZ)	S11		S21		S12		S22	
	MAG	ANG	MAG	ANG	MAG	ANG	MAG	ANG
500	.962	166.6	1.649	63.2	.007	41.9	.837	168.9
1000	.933	144.9	1.143	30.0	.015	32.2	.798	156.2
1500	.864	115.5	1.368	-12.1	.031	2.8	.726	142.6
2000	.548	64.6	2.320	-75.5	.059	-50.7	.526	137.3
2500	.220	-111.2	3.742	-173.7	.051	-138.8	.560	107.0
3000	.214	-85.0	4.634	7.9	.039	-126.8	.782	-128.3
3500	.923	178.6	.375	-118.7	.017	117.2	.898	166.5
4000	.953	150.4	.065	-162.9	.005	84.4	.939	147.5
4500	.952	131.2	.020	168.3	.001	75.2	.951	133.4
5000	.953	113.9	.008	143.6	.001	63.7	.957	119.1

### OUTPUT POWER vs. INPUT POWER

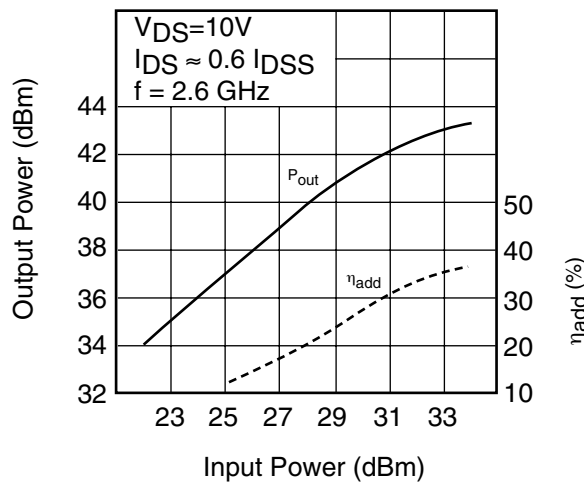

# FLL200IB-1, FLL200IB-2, FLL200IB-3

## L-Band Medium & High Power GaAs FET

### Case Style "IB" Metal-Ceramic Hermetic Package

