

FLK057WG

X, Ku Band Power GaAs FET

FEATURES

- High Output Power: $P_{1dB} = 27.0\text{dBm(Typ.)}$
- High Gain: $G_{1dB} = 7.0\text{dB(Typ.)}$
- High PAE: $\eta_{add} = 32\%\text{(Typ.)}$
- Proven Reliability
- Hermetic Metal/Ceramic Package

DESCRIPTION

The FLK057WG is a power GaAs FET that is designed for general purpose applications in the Ku-Band frequency range as it provides superior power, gain, and efficiency.

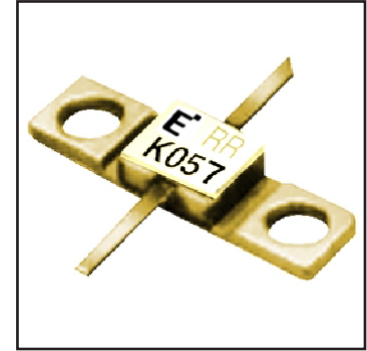

Eudyna stringent Quality Assurance Program assures the highest reliability and consistent performance.

ABSOLUTE MAXIMUM RATING (Ambient Temperature $T_a=25^\circ\text{C}$)

Item	Symbol	Condition	Rating	Unit
Drain-Source Voltage	V_{DS}		15	V
Gate-Source Voltage	V_{GS}		-5	V
Total Power Dissipation	P_T	$T_C = 25^\circ\text{C}$	3.75	W
Storage Temperature	T_{stg}		-65 to +175	$^\circ\text{C}$
Channel Temperature	T_{ch}		175	$^\circ\text{C}$

Eudyna recommends the following conditions for the reliable operation of GaAs FETs:

1. The drain-source operating voltage (V_{DS}) should not exceed 10 volts.
2. The forward and reverse gate currents should not exceed 4.4 and -0.25 mA respectively with gate resistance of 1000Ω .
3. The operating channel temperature (T_{ch}) should not exceed 145°C .

ELECTRICAL CHARACTERISTICS (Ambient Temperature $T_a=25^\circ\text{C}$)

Item	Symbol	Test Conditions	Limit			Unit
			Min.	Typ.	Max.	
Saturated Drain Current	I_{DSS}	$V_{DS} = 5\text{V}, V_{GS} = 0\text{V}$	-	200	300	mA
Transconductance	g_m	$V_{DS} = 5\text{V}, I_{DS} = 125\text{mA}$	-	100	-	mS
Pinch-off Voltage	V_p	$V_{DS} = 5\text{V}, I_{DS} = 10\text{mA}$	-1.0	-2.0	-3.5	V
Gate Source Breakdown Voltage	V_{GSO}	$I_{GS} = -10\mu\text{A}$	-5	-	-	V
Output Power at 1dB G.C.P.	P_{1dB}	$V_{DS} = 10\text{V},$ $I_{DS} = 0.6 I_{DSS} \text{(Typ.)},$ $f = 14.5 \text{GHz}$	26.0	27.0	-	dBm
Power Gain at 1dB G.C.P.	G_{1dB}		6.0	7.0	-	dB
Power-added Efficiency	η_{add}		-	32	-	%
Output Power at 1dB G.C.P.	P_{1dB}	$V_{DS} = 10\text{V},$ $I_{DS} = 0.6 I_{DSS} \text{(Typ.)},$ $f = 12 \text{GHz}$	-	27	-	dBm
Power Gain at 1dB G.C.P.	G_{1dB}		-	8	-	dB
Power-added Efficiency	η_{add}		-	34	-	%
Thermal Resistance	R_{th}	Channel to Case	-	20	40	$^\circ\text{C/W}$

CASE STYLE: WG

G.C.P.: Gain Compression Point

FLK057WG

X, Ku Band Power GaAs FET

POWER DERATING CURVE

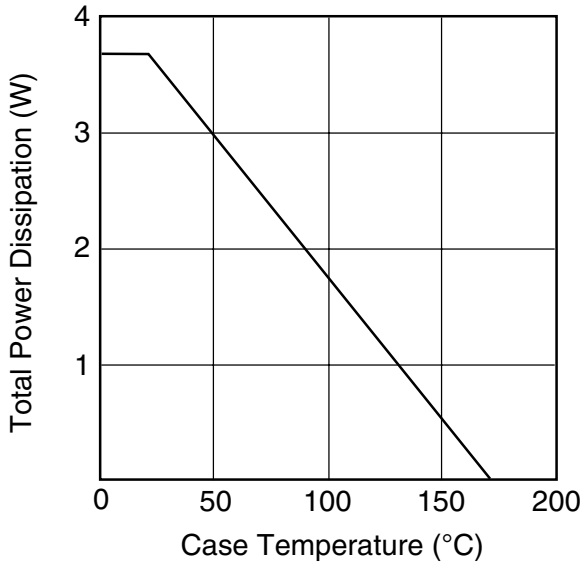

DRAIN CURRENT vs. DRAIN-SOURCE VOLTAGE

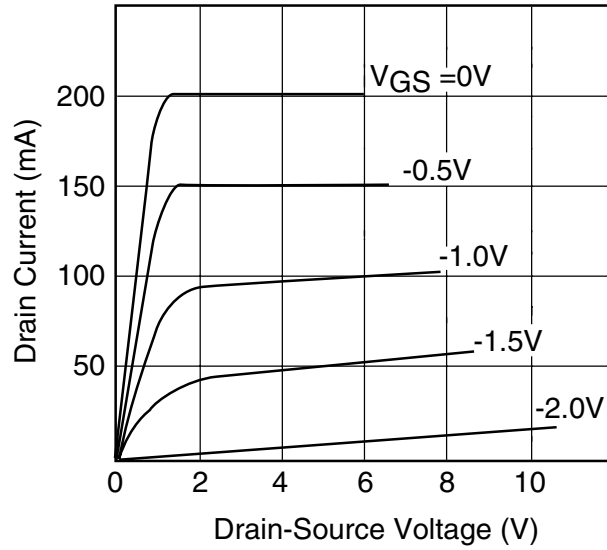

OUTPUT POWER vs. INPUT POWER

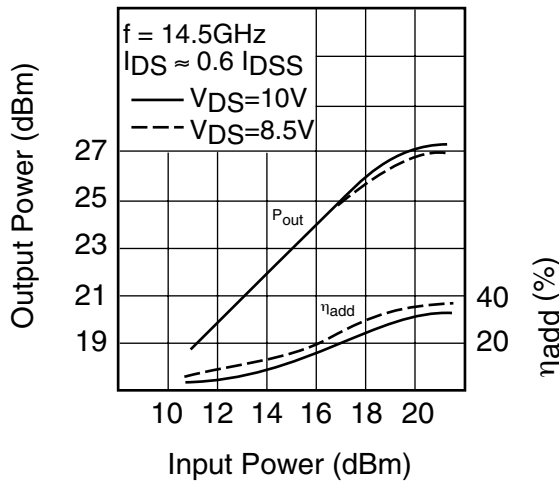

P_{1dB} & η_{add} vs. V_{DS}

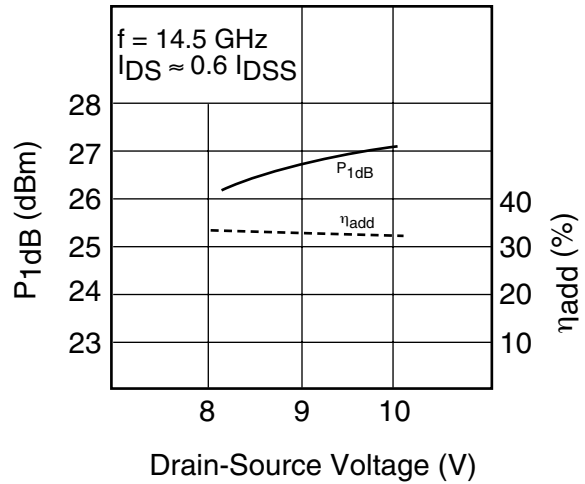

FLK057WG

X, Ku Band Power GaAs FET

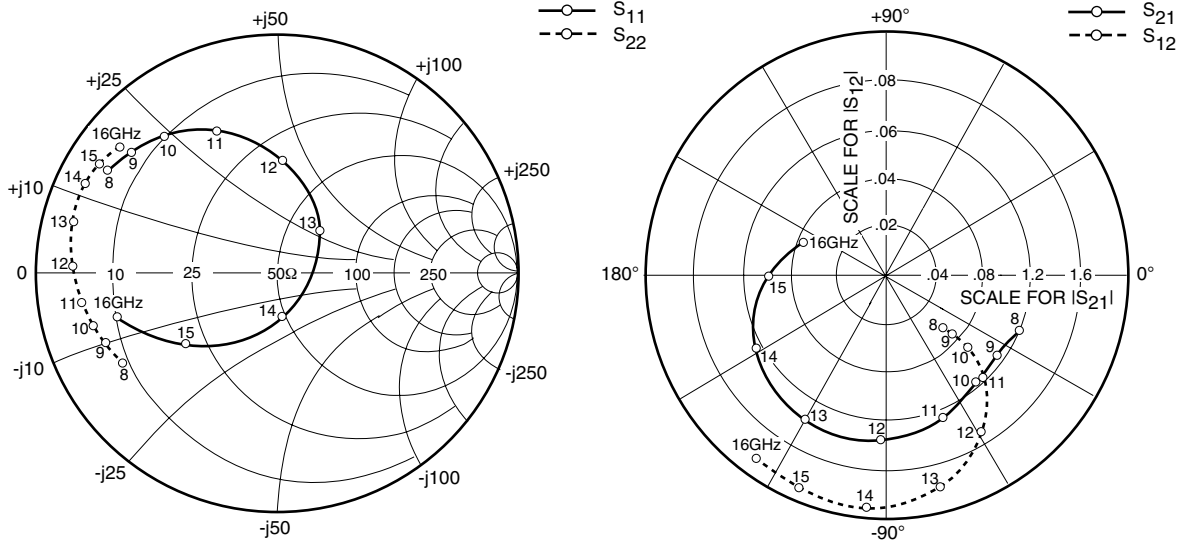

S-PARAMETERS

V_{DS} = 10V, I_{DS} = 120mA

FREQUENCY (MHZ)	S ₁₁		S ₂₁		S ₁₂		S ₂₂	
	MAG	ANG	MAG	ANG	MAG	ANG	MAG	ANG
500	.973	-47.8	7.249	147.9	.016	60.6	.545	-20.3
1000	.941	-85.1	5.946	121.8	.026	38.1	.519	-38.1
8000	.816	148.5	1.199	-21.6	.033	-41.3	.745	-149.2
9000	.787	139.7	1.125	-35.4	.037	-40.9	.773	-157.3
10000	.740	129.3	1.149	-49.4	.045	-40.5	.796	-163.0
11000	.642	112.7	1.251	-67.7	.058	-46.2	.819	-170.6
12000	.474	86.4	1.346	-91.6	.075	-58.5	.845	178.7
13000	.249	43.8	1.351	-119.6	.089	-75.4	.868	166.3
14000	.189	-83.7	1.227	-150.6	.095	-95.0	.878	155.2
15000	.480	-140.8	.980	-179.3	.093	-112.5	.868	148.7
16000	.689	-163.9	.752	158.6	.092	-125.9	.840	141.4

FLK057WG

X, Ku Band Power GaAs FET

Case Style "WG" Metal-Ceramic Hermetic Package

