

FLC057WG

C-Band Power GaAs FET

FEATURES

- High Output Power: $P_{1dB} = 27.0dBm(Typ.)$
- High Gain: $G_{1dB} = 9.0dB(Typ.)$
- High PAE: $\eta_{add} = 38\%(Typ.)$
- Proven Reliability
- Hermetic Metal/Ceramic Package

DESCRIPTION

The FLC057WG is a power GaAs FET that is designed for general purpose applications in the C-Band frequency range as it provides superior power, gain, and efficiency.

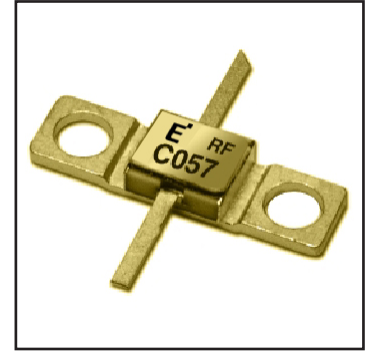

Eudyna stringent Quality Assurance Program assures the highest reliability and consistent performance.

ABSOLUTE MAXIMUM RATING (Ambient Temperature $T_a=25^\circ C$)

Item	Symbol	Condition	Rating	Unit
Drain-Source Voltage	V_{DS}		15	V
Gate-Source Voltage	V_{GS}		-5	V
Total Power Dissipation	P_T	$T_C = 25^\circ C$	3.75	W
Storage Temperature	T_{stg}		-65 to +175	$^\circ C$
Channel Temperature	T_{ch}		175	$^\circ C$

Eudyna recommends the following conditions for the reliable operation of GaAs FETs:

1. The drain-source operating voltage (V_{DS}) should not exceed 10 volts.
2. The forward and reverse gate currents should not exceed 4.4 and -0.25 mA respectively with gate resistance of 1000 Ω .
3. The operating channel temperature (T_{ch}) should not exceed 145 $^\circ C$.

ELECTRICAL CHARACTERISTICS (Ambient Temperature $T_a=25^\circ C$)

Item	Symbol	Test Conditions	Limit			Unit
			Min.	Typ.	Max.	
Saturated Drain Current	I_{DSS}	$V_{DS} = 5V, V_{GS} = 0V$	-	200	300	mA
Transconductance	g_m	$V_{DS} = 5V, I_{DS} = 125mA$	-	100	-	mS
Pinch-off Voltage	V_p	$V_{DS} = 5V, I_{DS} = 10mA$	-1.0	-2.0	-3.5	V
Gate Source Breakdown Voltage	V_{GSO}	$I_{GS} = -10\mu A$	-5	-	-	V
Output Power at 1dB G.C.P.	P_{1dB}	$V_{DS} = 10V$ $I_{DS} \approx 0.6 I_{DSS} (Typ.)$, $f = 8 GHz$	25.5	27.0	-	dBm
Power Gain at 1dB G.C.P.	G_{1dB}		8.0	9.0	-	dB
Power-added Efficiency	η_{add}		-	38	-	%
Thermal Resistance	R_{th}	Channel to Case	-	27	40	$^\circ C/W$

CASE STYLE: WG

G.C.P.: Gain Compression Point

FLC057WG

C-Band Power GaAs FET

POWER DERATING CURVE

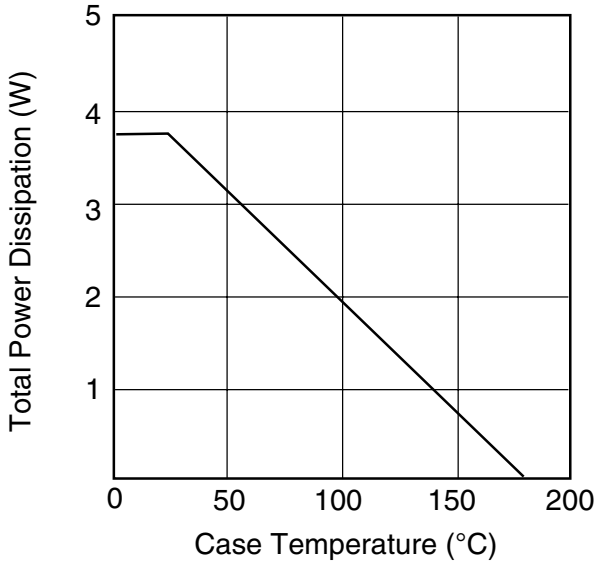

DRAIN CURRENT vs. DRAIN-SOURCE VOLTAGE

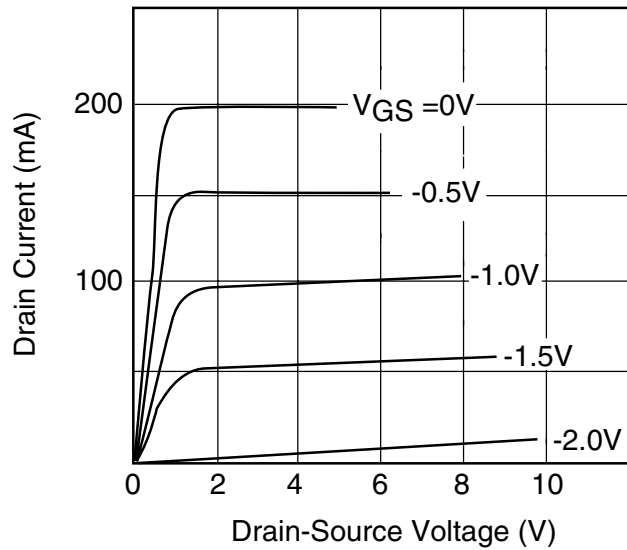

OUTPUT POWER vs. INPUT POWER

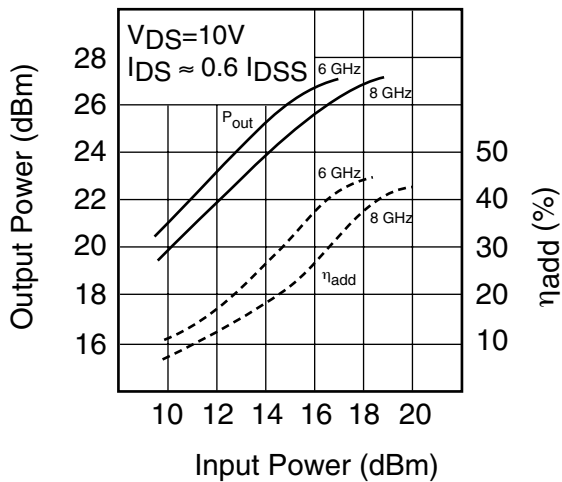

P1dB & η_{add} vs. V_{DS}

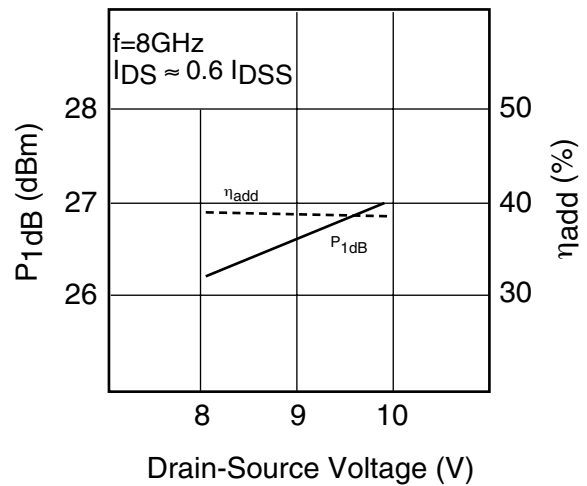

FLC057WG

C-Band Power GaAs FET

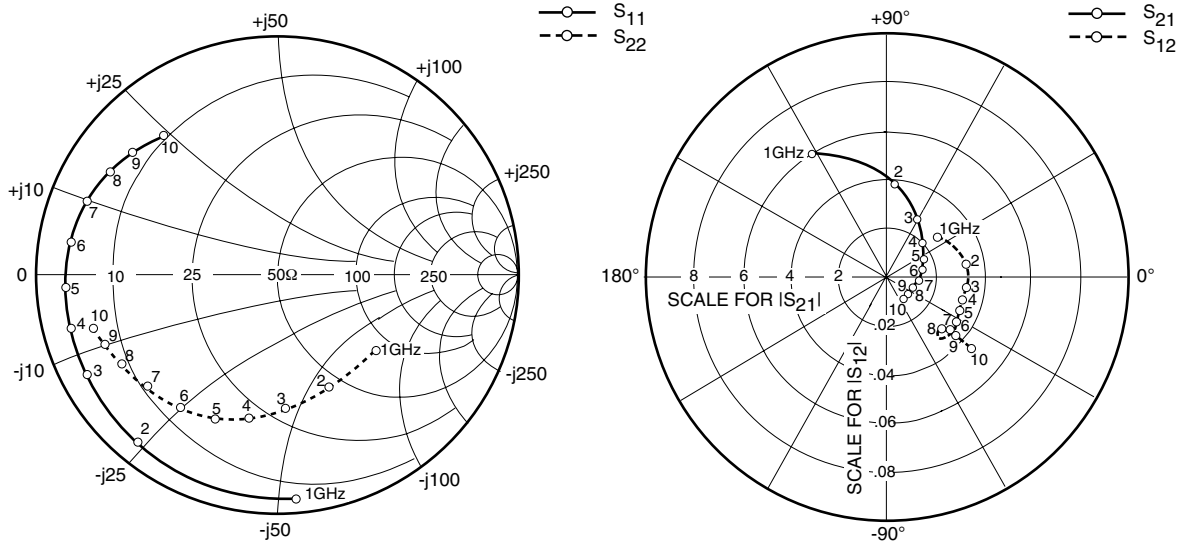

S-PARAMETERS

$V_{DS} = 10V, I_{DS} = 125mA$

FREQUENCY (MHZ)	S11		S21		S12		S22	
	MAG	ANG	MAG	ANG	MAG	ANG	MAG	ANG
500	.973	-47.9	7.249	147.9	.016	60.6	.545	-20.4
1000	.941	-85.1	5.946	121.8	.026	38.1	.519	-38.2
2000	.912	-129.5	3.846	86.0	.033	8.9	.514	-66.2
3000	.897	-151.8	2.675	62.2	.033	-8.5	.562	-86.5
4000	.889	-164.8	2.058	44.1	.032	-17.6	.618	-101.2
5000	.881	-176.2	1.712	27.8	.033	-25.1	.658	-113.0
6000	.869	171.6	1.506	11.2	.033	-31.0	.689	-125.1
7000	.847	159.0	1.339	-6.1	.035	-39.4	.717	-138.5
8000	.816	148.5	1.199	-21.6	.033	-41.3	.745	-149.3
9000	.787	139.7	1.125	-35.4	.037	-41.0	.773	-157.4
10000	.740	129.4	1.149	-49.4	.045	-40.5	.796	-163.1

Case Style "WG" Metal-Ceramic Hermetic Package

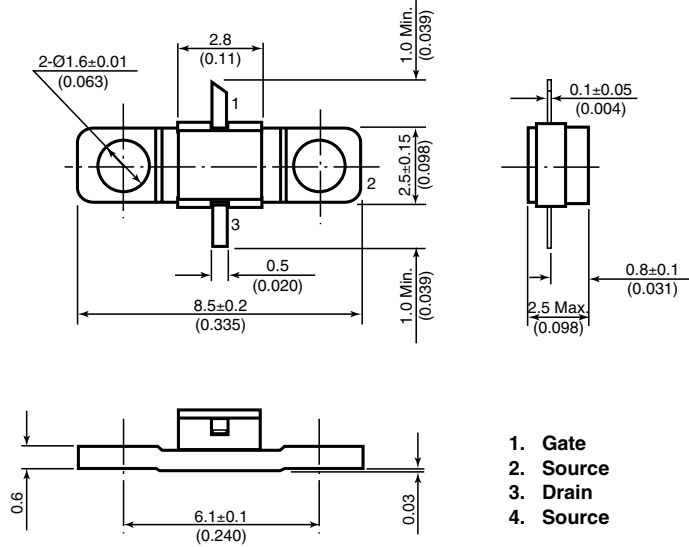

Unit: mm(inches)