



EMM5832VU

K-Band Power Amplifier MMIC

FEATURES

- High Output Power: Pout=31.0dBm (typ.)
- High Linear Gain: GL=20.0dB (typ.)
- Broad Band: 21.2 to 26.5GHz
- Impedance Matched Zin/Zout=50ohm
- Small Hermetic Metal-Ceramic SMT Package (VU)

DESCRIPTION

The EMM5832VU is a MMIC amplifier that contains a four-stage amplifier, internally matched, for standard communications band in the 21.2 to 26.5GHz frequency range.

SEDI's stringent Quality Assurance Program assures the highest reliability and consistent performance.

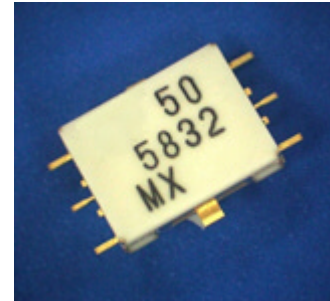

ABSOLUTE MAXIMUM RATING

Item	Symbol	Rating	Unit
Drain-Source Voltage	V _{DD}	10	V
Gate-Source Voltage	V _{GG}	-3	V
Input Power	P _{in}	22	dBm
Storage Temperature	T _{stg}	-55 to +125	deg.C

RECOMMENDED OPERATING CONDITIONS

Item	Symbol	Condition	Unit
Drain-Source Voltage	V _{DD}	=< 7	V
Input Power	P _{in}	=<12	dBm
Operating Case Temperature	T _C	-40 to +85	deg.C

ELECTRICAL CHARACTERISTICS (Case Temperature Tc=25deg.C)

Item	Symbol	Test Conditions	Limits			Unit
			Min.	Typ.	Max.	
Frequency Range	f	VDD=6.0V	21.2	-	26.5	GHz
Output Power at 1dB G.C.P.	P1dB	IDD(DC)=800mA typ.	28	31	-	dBm
Power Gain at 1dB G.C.P.	G1dB	Zs=Zl=50ohm	16	19	23	dB
Power-added Efficiency at 1dB G.C.P.	Nadd		-	20	-	%
Drain Current at 1dB G.C.P.	Iddrf		-	1000	1500	mA
Third Order Intermodulation Distortion	IM3	* : df=+10MHz	-28	-33	-	dBc
Input Return Loss (at Pin=-20dBm)	RLin	Pout=20.0dBm	-	8	-	dB
Output Return Loss (at Pin=-20dBm)	RLout	(S.C.L)	-	8	-	dB

G.C.P. : Gain Compression Point

S.C.L. : Single Carrier Level

ESD	Class 0	=< 250V
-----	---------	---------

Note : Based on JEDEC JESD22-A114C (C=100pF, R=1.5kohm)

CASE STYLE	VU
RoHS COMPLIANCE	YES

ORDERING INFORMATION

Part Number	Order Unit	Packing
EMM5832VU	No Limitation	48 pcs./Tray × 4 Tray = 192 pcs./Packing
EMM5832VUT	500pcs.	500 pcs./Reel × 1 Reel = 500 pcs./Packing

OUTPUT POWER vs. FREQUENCY

VDD=6V, IDD(DC)=800mA

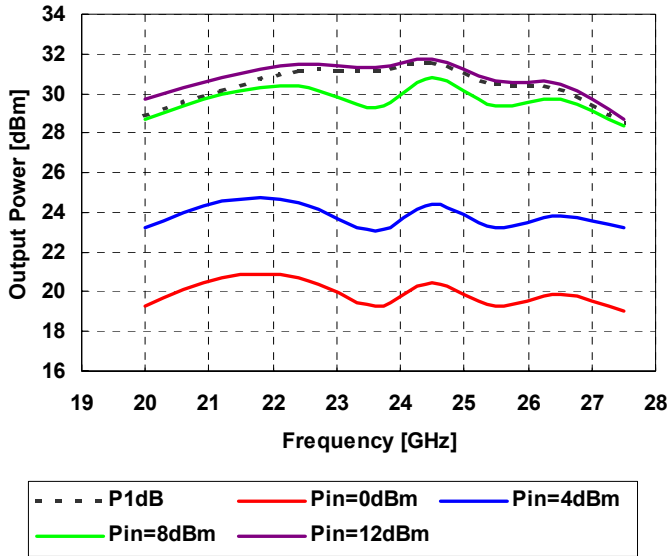

OUTPUT POWER, DRAIN CURRENT vs. INPUT POWER

VDD=6V, IDD(DC)=800mA

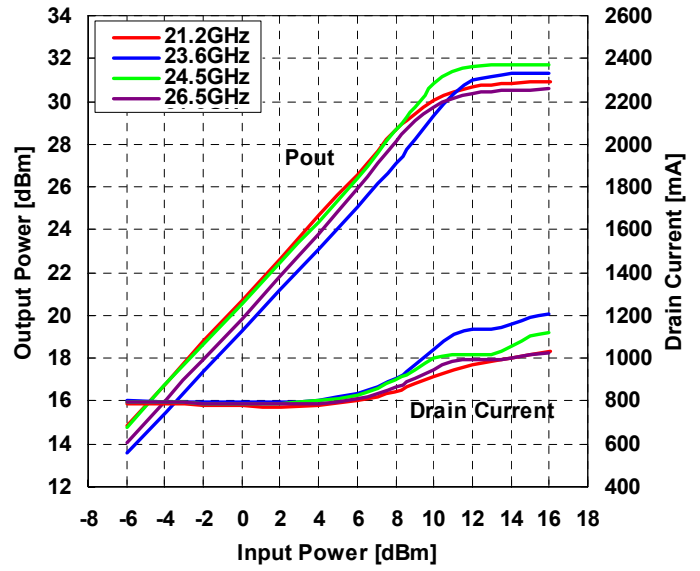

POWER-ADDED EFFICIENCY vs. FREQUENCY

VDD=6V, IDD(DC)=800mA

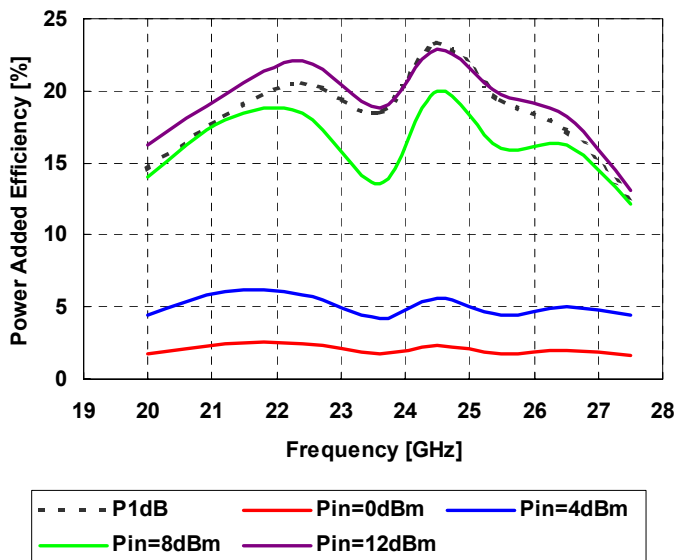



EMM5832VU

K-Band Power Amplifier MMIC

IMD vs. FREQUENCY

VDD=6V, IDD(DC)=800mA, Pout=20dBm S.C.L

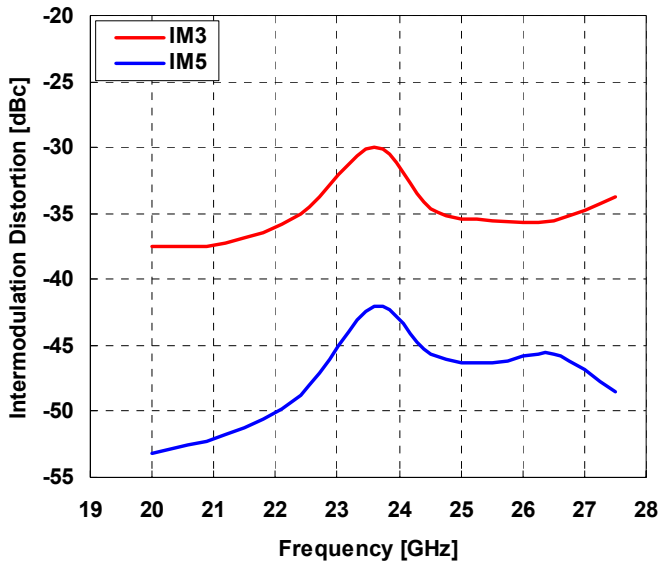

IMD vs. OUTPUT POWER

VDD=6V, IDD(DC)=800mA

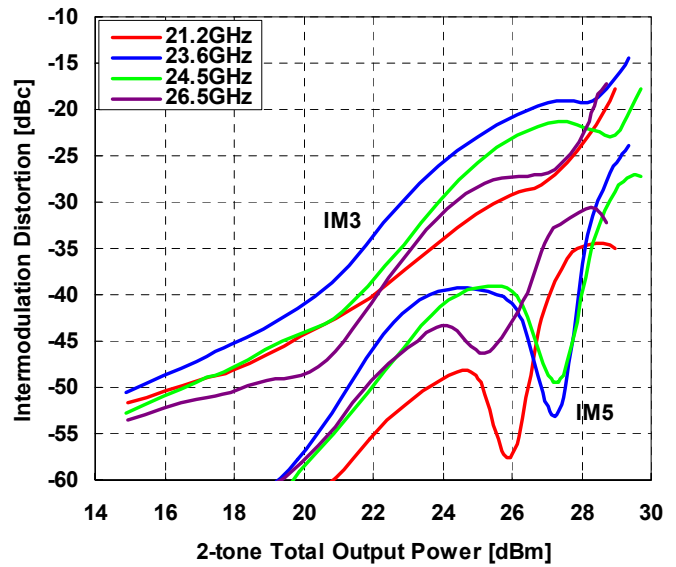

OUTPUT POWER, GAIN vs. DRAIN CURRENT

VDD=6V

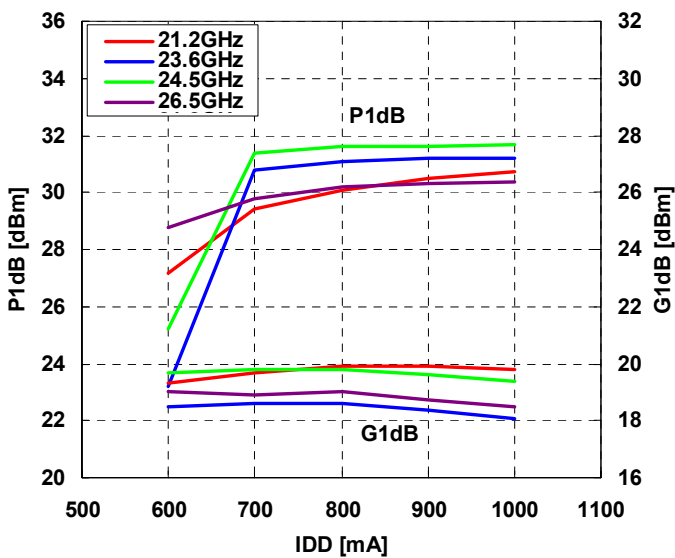

OUTPUT POWER, GAIN vs. DRAIN VOLTAGE

IDD(DC)=800mA

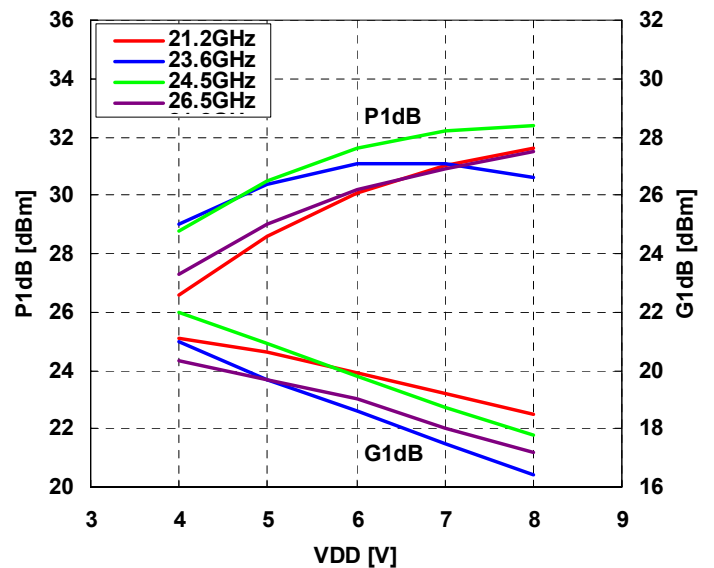



EMM5832VU

K-Band Power Amplifier MMIC

OUTPUT POWER, DRAIN CURRENT
vs. INPUT POWER by Drain Voltage

IDD(DC)=800mA, f=21.2GHz

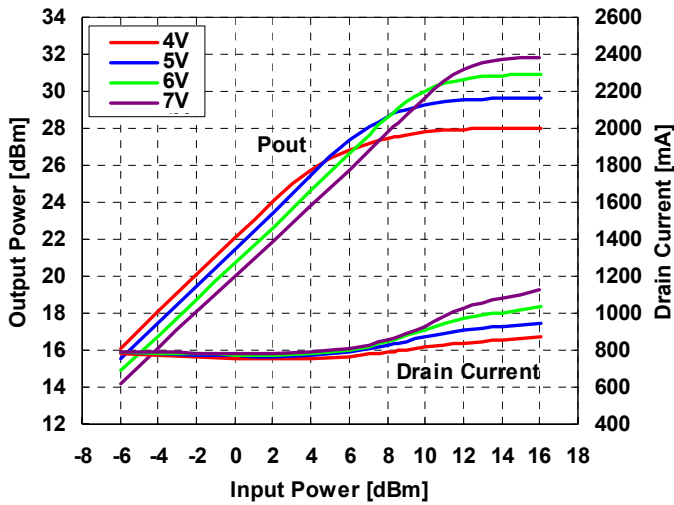

OUTPUT POWER, DRAIN CURRENT
vs. INPUT POWER by Drain Voltage

IDD(DC)=800mA, f=23.6GHz

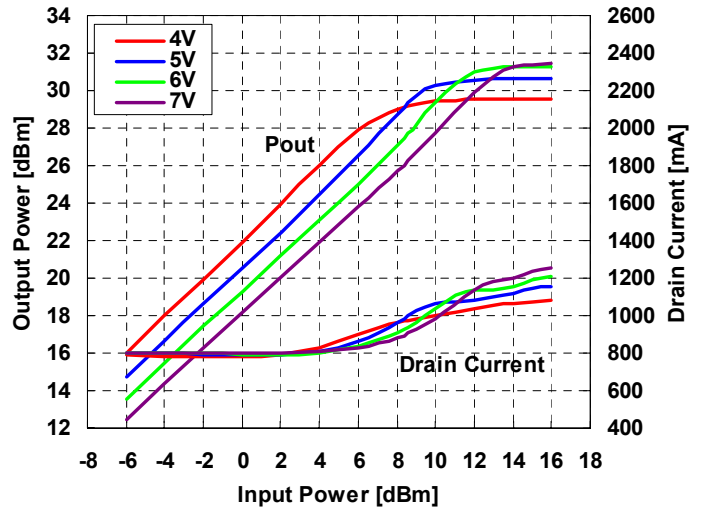

OUTPUT POWER, DRAIN CURRENT
vs. INPUT POWER by Drain Voltage

IDD(DC)=800mA, f=24.5GHz

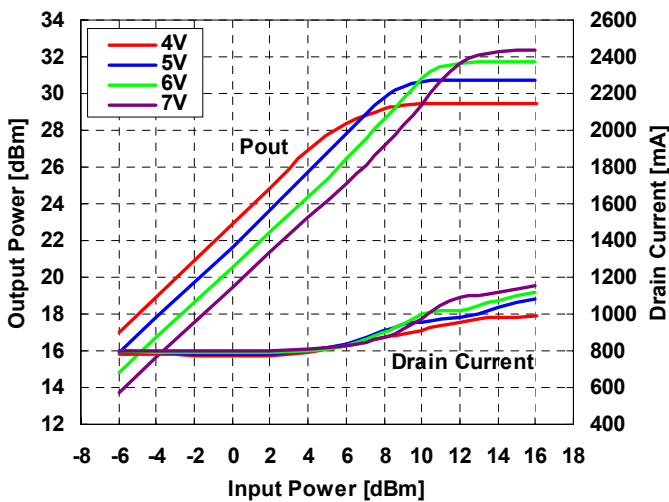

OUTPUT POWER, DRAIN CURRENT
vs. INPUT POWER by Drain Voltage

IDD(DC)=800mA, f=26.5GHz

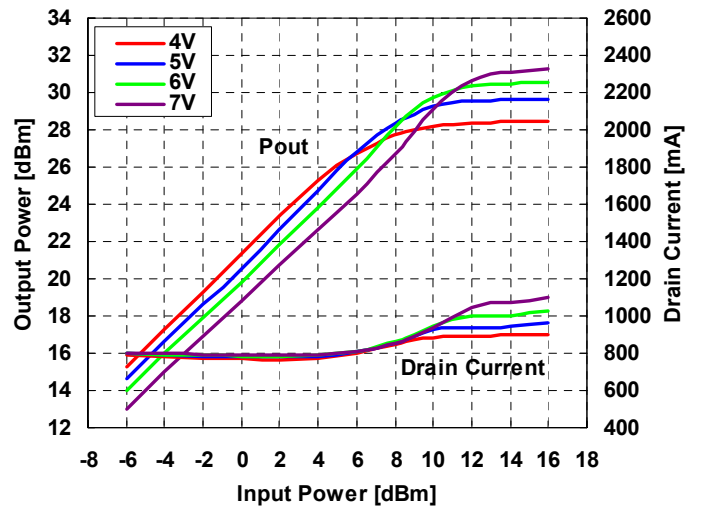



EMM5832VU

K-Band Power Amplifier MMIC

OUTPUT POWER, DRAIN CURRENT vs. INPUT POWER by Drain Current

VDD=6V, f=21.2GHz

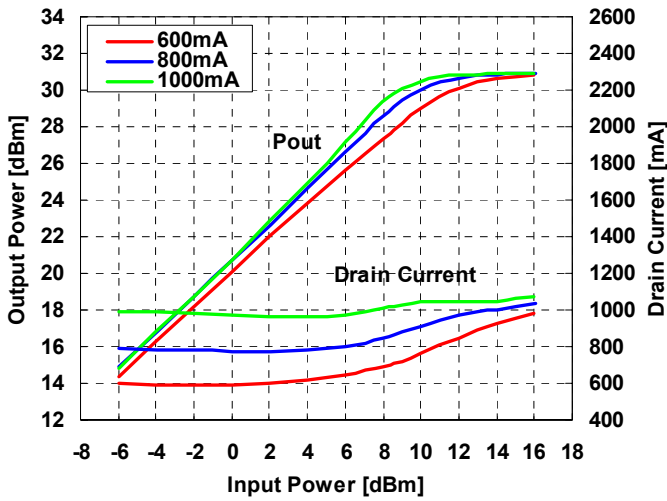

OUTPUT POWER, DRAIN CURRENT vs. INPUT POWER by Drain Current

VDD=6V, f=23.6GHz

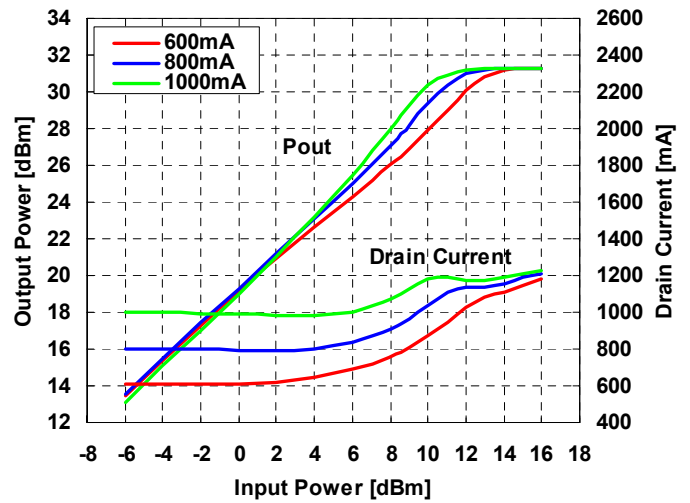

OUTPUT POWER, DRAIN CURRENT vs. INPUT POWER by Drain Current

VDD=6V, f=24.5GHz

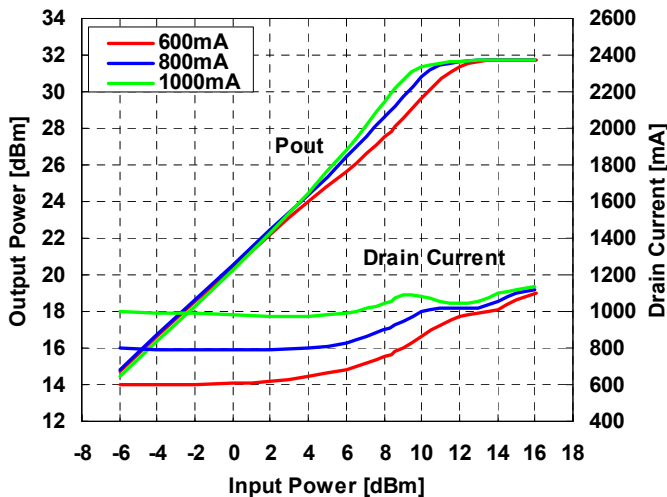

OUTPUT POWER, DRAIN CURRENT vs. INPUT POWER by Drain Current

VDD=6V, f=26.5GHz

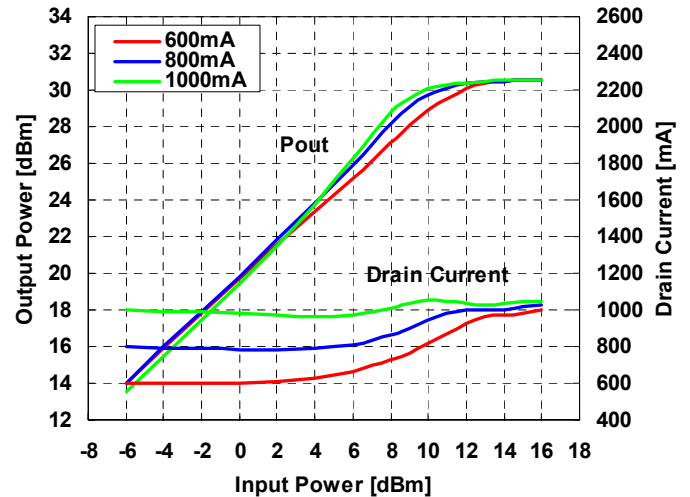



EMM5832VU

K-Band Power Amplifier MMIC

IMD PERFORMANCE vs. OUTPUT POWER by Drain Voltage

IDD(DC)=800mA, f=21.2GHz

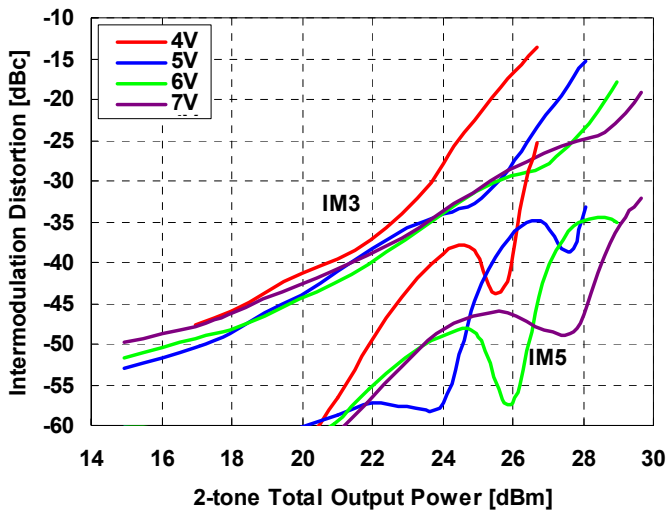

IMD PERFORMANCE vs. OUTPUT POWER by Drain Voltage

IDD(DC)=800mA, f=23.6GHz

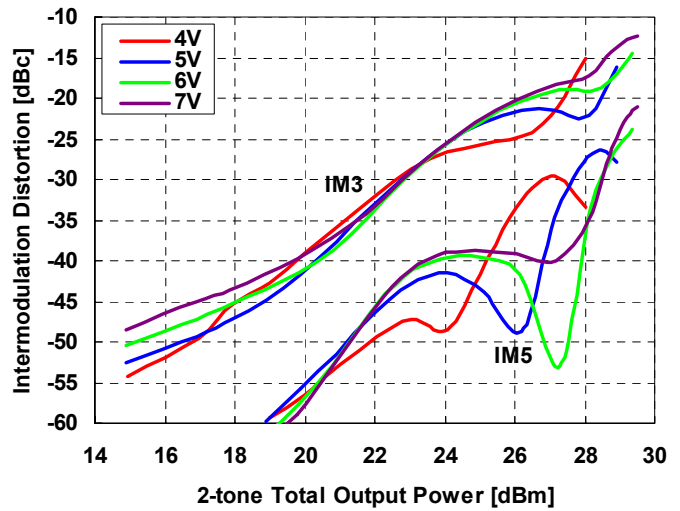

IMD PERFORMANCE vs. OUTPUT POWER by Drain Voltage

IDD(DC)=800mA, f=24.5GHz

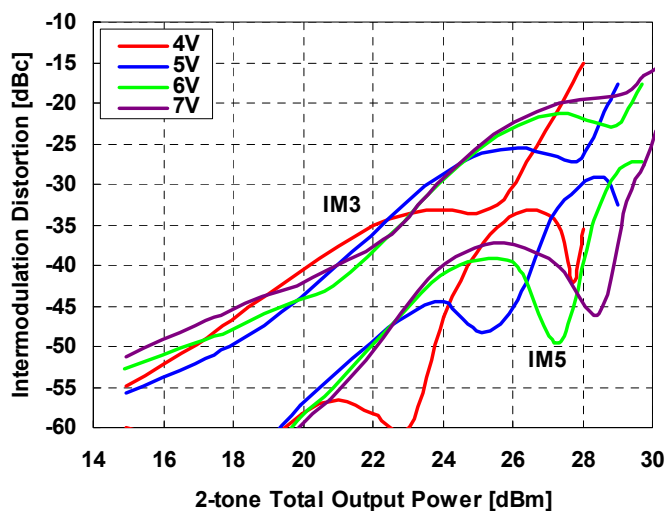

IMD PERFORMANCE vs. OUTPUT POWER by Drain Voltage

IDD(DC)=800mA, f=26.5GHz

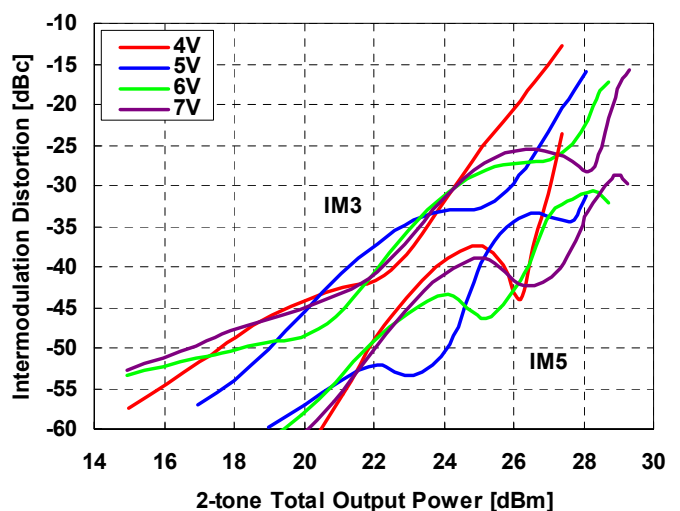



EMM5832VU

K-Band Power Amplifier MMIC

IMD PERFORMANCE vs. OUTPUT POWER by Drain Current

VDD=6V, f=21.2GHz

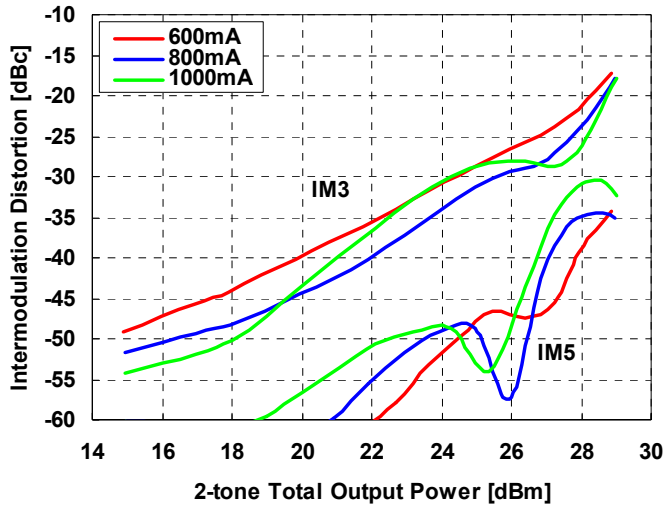

IMD PERFORMANCE vs. OUTPUT POWER by Drain Current

VDD=6V, f=23.6GHz

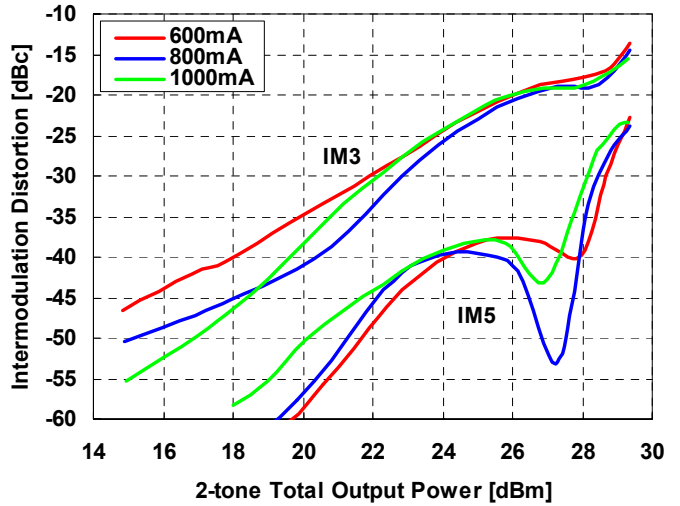

IMD PERFORMANCE vs. OUTPUT POWER by Drain Current

VDD=6V, f=24.5GHz

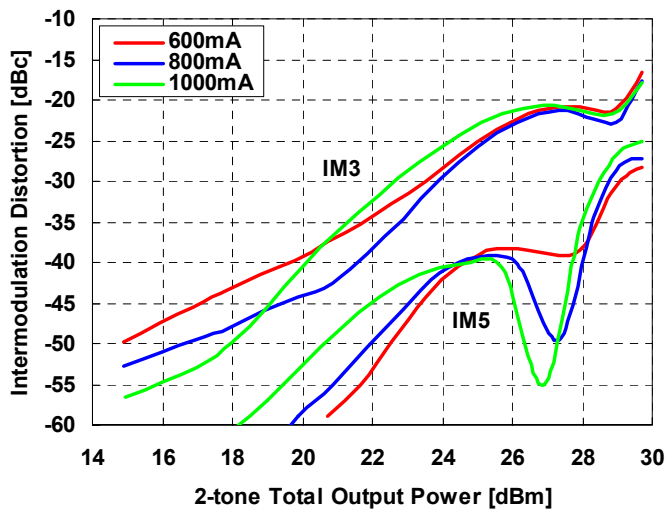

IMD PERFORMANCE vs. OUTPUT POWER by Drain Current

VDD=6V, f=26.5GHz

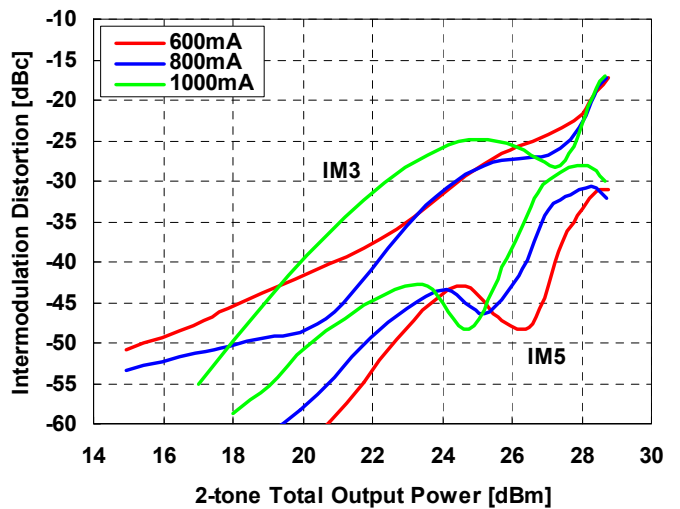



EMM5832VU

K-Band Power Amplifier MMIC

■ S-PARAMETER

VDD=6V, IDD=800mA

Frequency [GHz]	S11		S21		S12		S22	
	MAG	ANG	MAG	ANG	MAG	ANG	MAG	ANG
1.0	0.98	-32.4	0.01	-30.1	0.00	165.4	0.97	-49.9
2.0	0.93	-62.5	0.02	45.1	0.00	144.3	0.92	-90.2
3.0	0.93	-84.7	0.02	-38.2	0.00	167.6	0.92	-120.7
4.0	0.94	-103.5	0.02	-94.5	0.00	166.4	0.93	-149.6
5.0	0.93	-127.4	0.02	-130.9	0.00	132.8	0.91	174.3
6.0	0.90	-159.1	0.02	-169.6	0.00	102.5	0.88	136.1
7.0	0.89	168.7	0.02	170.9	0.00	14.9	0.89	107.2
8.0	0.89	143.8	0.04	153.3	0.00	-13.0	0.92	84.9
9.0	0.89	121.2	0.10	105.3	0.00	-100.8	0.90	55.4
10.0	0.84	89.4	0.24	47.3	0.00	-158.6	0.87	15.9
11.0	0.80	45.0	0.43	-60.8	0.00	162.8	0.89	-12.3
12.0	0.83	9.7	0.33	-147.1	0.00	-68.9	0.90	-25.2
13.0	0.85	-7.1	0.25	156.4	0.00	-83.4	0.89	-34.6
14.0	0.85	-16.0	0.23	110.3	0.00	-135.2	0.87	-51.2
15.0	0.83	-33.3	0.20	62.6	0.01	-170.4	0.84	-78.8
16.0	0.78	-64.9	0.12	72.6	0.01	115.9	0.83	-105.9
17.0	0.79	-99.5	0.79	67.6	0.00	21.9	0.82	-125.5
18.0	0.81	-120.6	4.02	-21.4	0.00	-82.4	0.77	-142.9
19.0	0.76	-128.6	6.67	-150.4	0.00	-115.8	0.56	-164.7
20.0	0.71	-139.8	8.59	118.6	0.00	174.5	0.27	139.1
21.0	0.52	-175.1	10.65	17.0	0.00	64.8	0.21	-19.6
21.2	0.48	172.6	10.84	-2.4	0.00	22.7	0.23	-34.5
21.4	0.45	159.4	10.99	-22.2	0.00	-26.9	0.24	-49.2
21.6	0.43	145.7	11.12	-41.7	0.00	-102.6	0.25	-66.2
21.8	0.43	133.3	11.17	-61.3	0.00	-157.3	0.27	-86.0
22.0	0.44	120.9	11.06	-80.7	0.00	128.8	0.28	-107.0
22.2	0.45	109.7	10.93	-99.4	0.00	63.7	0.30	-124.3
22.4	0.46	100.0	11.02	-117.8	0.00	20.8	0.34	-139.3
22.6	0.46	91.2	11.12	-136.6	0.00	-0.5	0.39	-152.2
22.8	0.44	84.0	11.12	-157.0	0.00	-12.0	0.46	-164.9
23.0	0.42	77.6	10.93	-176.4	0.00	-34.0	0.51	-176.8
23.2	0.39	72.6	10.63	163.5	0.00	-50.9	0.54	173.3
23.4	0.36	66.2	10.12	145.1	0.00	-57.0	0.53	164.9
23.6	0.32	59.2	9.66	128.0	0.00	-64.5	0.52	160.0
23.8	0.27	50.4	9.53	111.5	0.00	-73.2	0.49	157.5
24.0	0.20	38.1	9.38	95.6	0.00	-73.5	0.47	156.9
24.2	0.14	16.4	9.47	79.2	0.00	-77.1	0.45	158.0
24.4	0.10	-31.6	9.97	62.5	0.00	-70.3	0.45	160.3
24.6	0.13	-93.2	10.88	43.7	0.00	-60.7	0.47	159.0
24.8	0.21	-131.1	11.84	19.9	0.01	-71.2	0.48	151.3
25.0	0.25	-155.7	11.72	-7.8	0.01	-92.4	0.42	140.5
25.2	0.26	-171.8	10.52	-33.0	0.01	-111.0	0.34	135.6
25.4	0.25	179.6	9.21	-53.4	0.01	-126.2	0.28	134.8
25.6	0.24	175.9	8.30	-70.4	0.01	-127.9	0.24	130.5
25.8	0.23	174.3	7.97	-85.2	0.00	-130.5	0.20	121.0
26.0	0.24	172.5	8.12	-101.7	0.00	-136.5	0.15	106.8
26.2	0.25	168.8	8.57	-121.4	0.00	-143.3	0.10	88.6
26.4	0.26	162.7	8.90	-143.6	0.00	-158.3	0.07	61.7
26.6	0.27	154.5	9.23	-167.8	0.00	-165.8	0.05	23.1
26.8	0.28	145.3	9.45	166.6	0.00	-172.7	0.06	-16.6
27.0	0.28	132.0	9.41	137.8	0.00	-165.6	0.07	-50.7
28.0	0.15	-125.7	4.59	-25.6	0.01	96.4	0.21	-173.2
29.0	0.62	-168.9	0.81	-156.4	0.01	-99.6	0.40	-168.3
30.0	0.71	155.4	0.05	150.2	0.01	-179.6	0.56	172.9
31.0	0.64	119.8	0.01	157.7	0.01	-15.9	0.43	158.8
32.0	0.64	88.1	0.01	167.4	0.01	-107.6	0.34	124.5
33.0	0.71	76.0	0.00	-172.0	0.01	-116.2	0.55	81.1
34.0	0.79	67.6	0.00	-164.3	0.01	-133.6	0.69	62.8
35.0	0.72	42.5	0.01	-119.5	0.01	-124.2	0.65	45.5
36.0	0.54	-9.8	0.02	-174.3	0.02	-177.1	0.51	-3.1
37.0	0.61	-49.6	0.03	115.0	0.03	115.8	0.55	-50.8
38.0	0.74	-53.9	0.03	28.5	0.03	24.8	0.66	-59.6
39.0	0.73	-53.6	0.04	-22.8	0.04	-28.7	0.65	-65.9
40.0	0.37	-82.9	0.06	-120.3	0.06	-118.6	0.45	-100.3



EMM5832VU

K-Band Power Amplifier MMIC

S-PARAMETER

VDD=6V, IDD(DC)=800mA

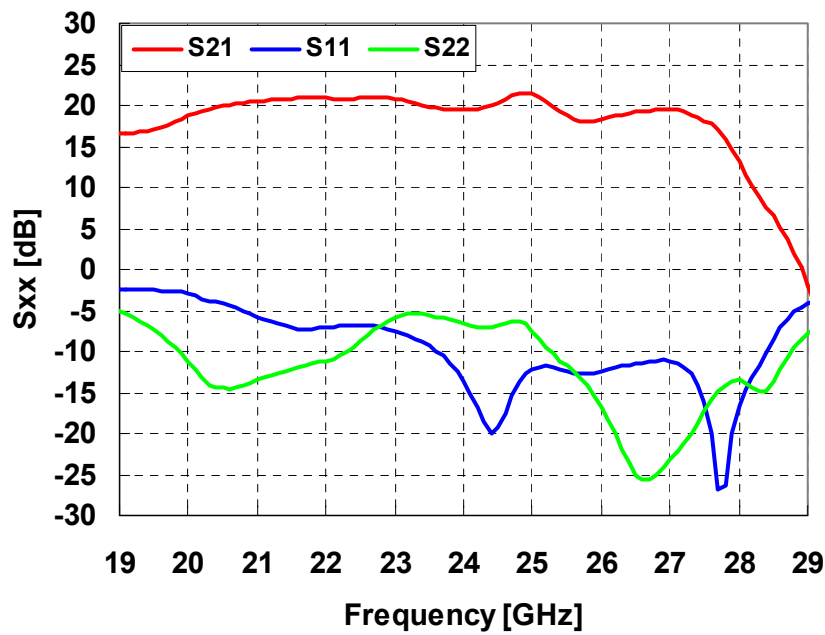
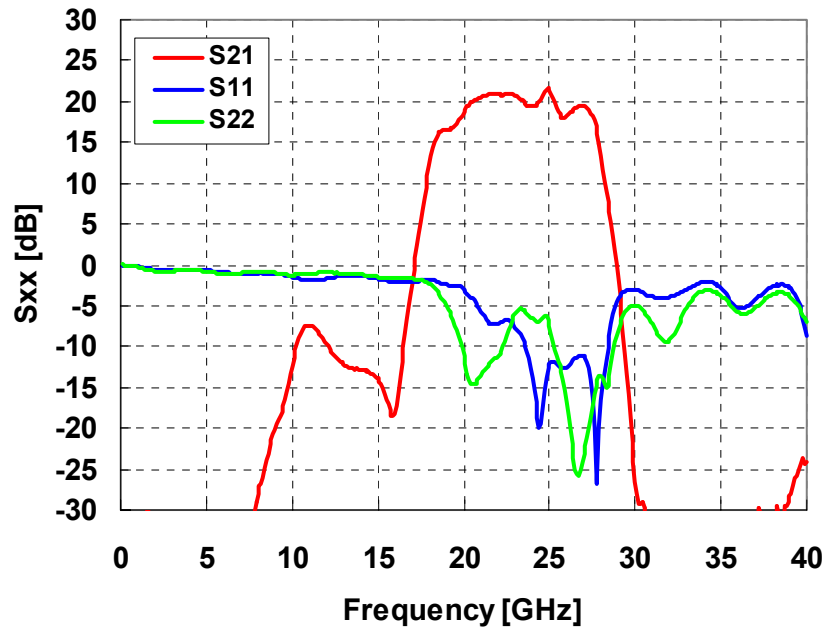



EMM5832VU

K-Band Power Amplifier MMIC

ΔT_{ch} vs. Drain Voltage
(Reference)

$I_{DD}=800mA$

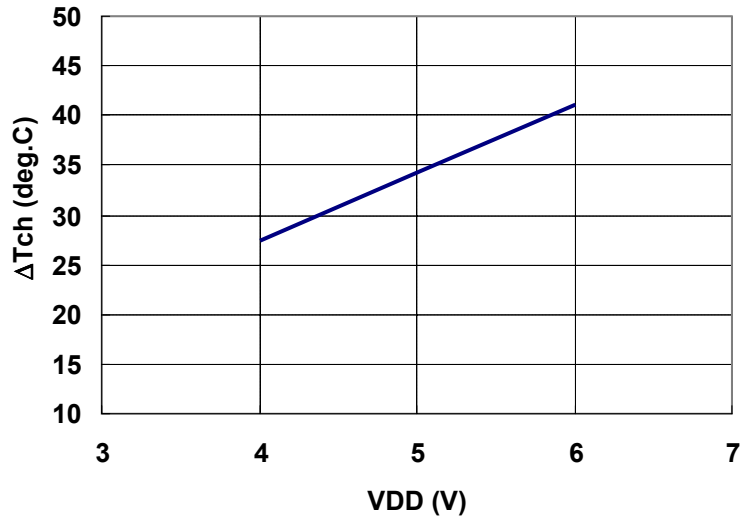

Note: ΔT_{ch} : Temperature Rise from Backside of the Package to Channel.

MTTF vs. T_{ch}

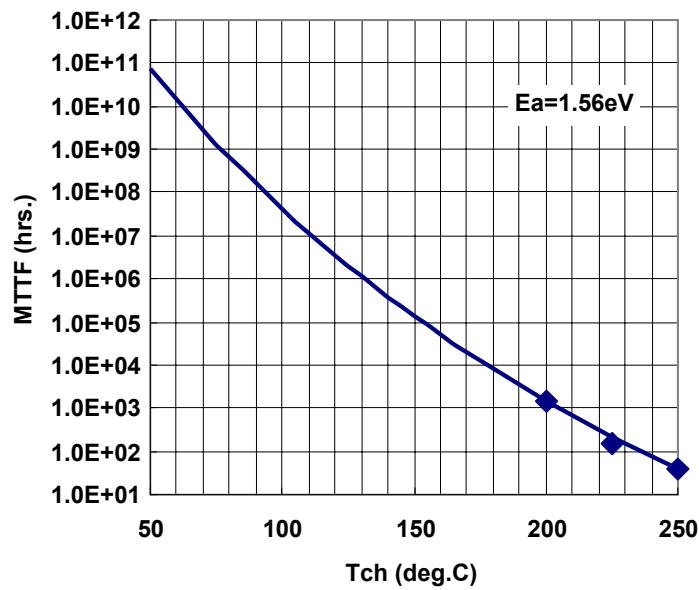

■ Mounting Instructions for VU Package for Lead-free solder

Mounting Condition

(1) For soldering, Lead-free solder (Sn-3.0Ag-0.5Cu)*1 or equivalent shall be used.

(*1: The figure displays with weight %. A predominantly tin-rich alloy with 3.0% silver and 0.5% copper.)

(2) A rosin type flux with a chlorine content of 0.2% or less shall be used. The rosin flux with low halogen content is recommended.

(3) When soldering, use one of the following time / temperature methods for acceptable solder joints. Make sure the devices have been properly prepared with flux prior soldering.

* Reflow soldering method (Infrared reflow / Heat circulation reflow / Hot plate reflow):

Limit solder to 3 reflow cycles because resin is used in the modules manufacturing process. Excessive reflow cycles will effect the resin resulting in a potential failure or latent defect. The recommended reflow temperature profile is shown below. The temperature of the reflow profile must be measured at the device body surface.

Reflow temperature profile and condition:

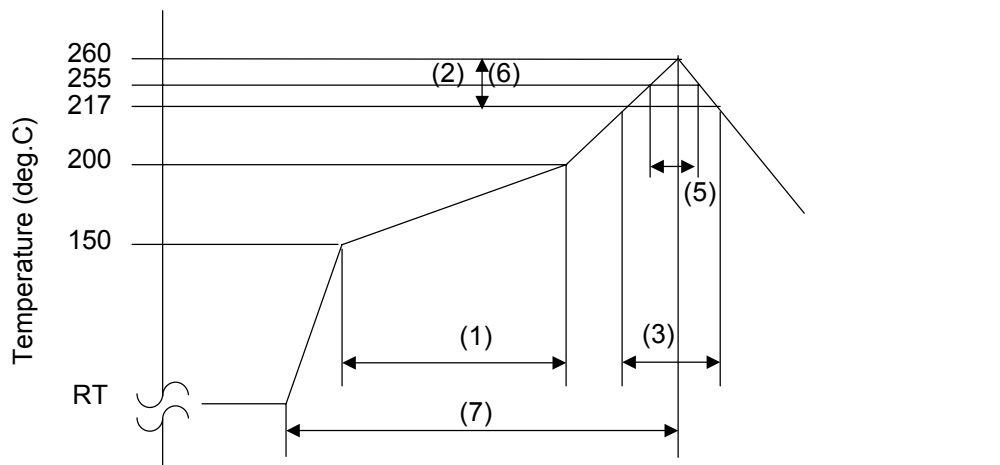

(1) Preheating:	150 – 200 deg.C, 60 – 120 seconds
(2) Ramp-up Rate:	3 deg.C /seconds max
(3) Liquidous temperature and time:	217 deg.C, 60 – 150 seconds
(4) Peak Temperature:	260 deg.C
(5) Time Peak Temperature within 5 deg.C:	< 30seconds
(6) Ramp-down Rate:	6 deg.C /seconds max
(7) Time RT to peak temperature:	8 minutes max

* Measurement point: Center of the package body surface

(4) The above-recommended conditions were confirmed using the manufacture's equipment and materials. However, when soldering these products, the soldering condition should be verified by customer using their equipment and materials.

■ Block diagram

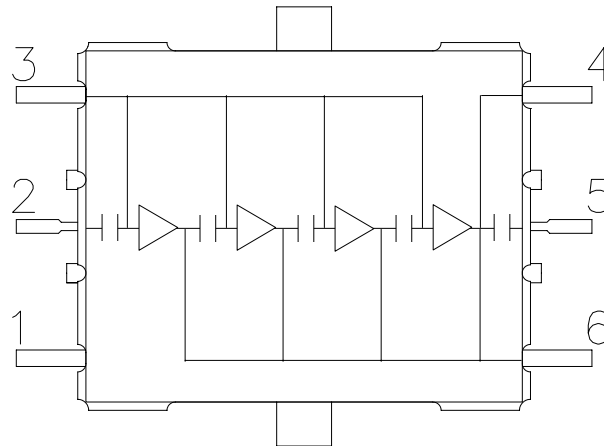

PIN ASSIGNMENT

- 1 : N.C.
- 2 : RF in
- 3 : VGG
- 4 : VDD
- 5 : RF out
- 6 : VDD

■ Recommended Bias Circuit

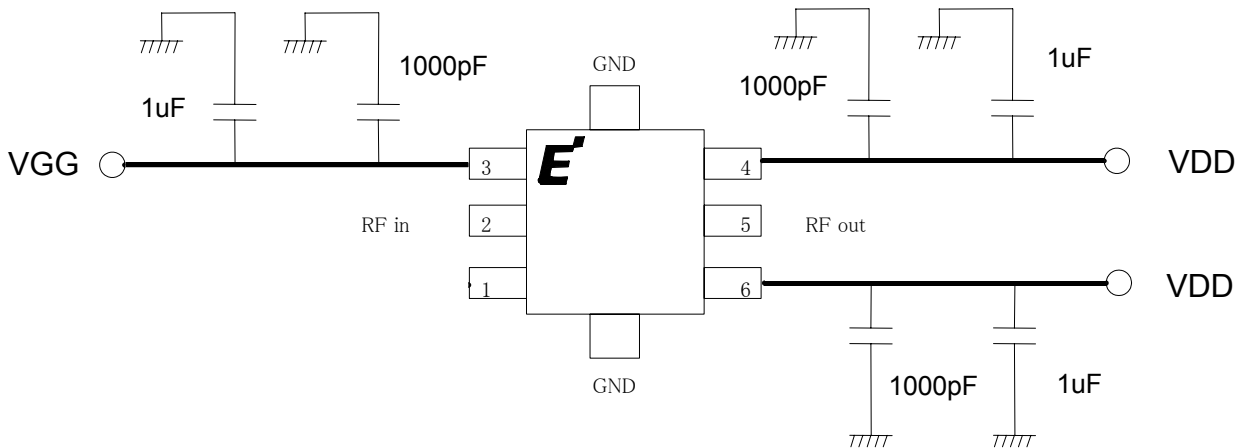

Note 1: The capacitors are recommended on the bias supply line, close to the package, in order to prevent video oscillations which could damage the module.

Note 2: Two pins named VDD are internally connected.



EMM5832VU

K-Band Power Amplifier MMIC

■ Package Outline

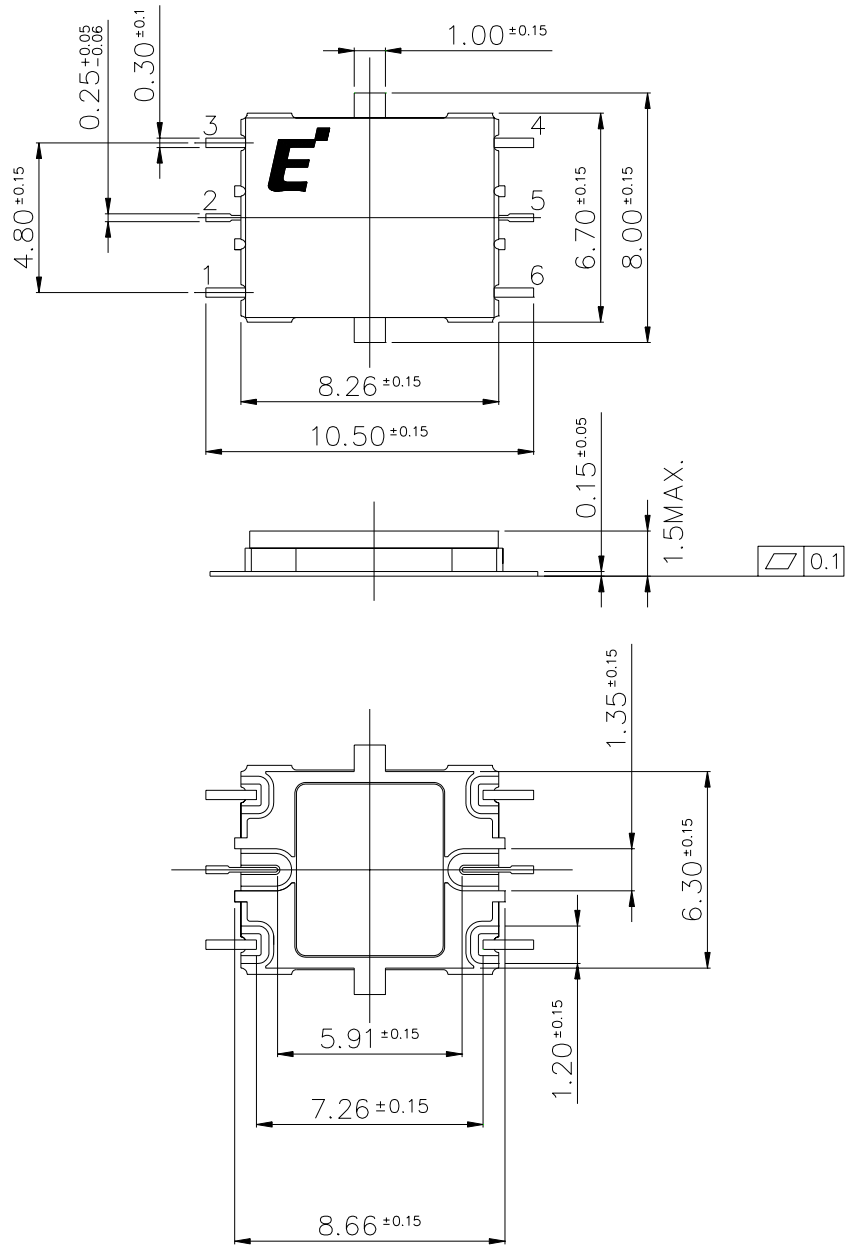

■ PCB Pads and Solder-resist Pattern

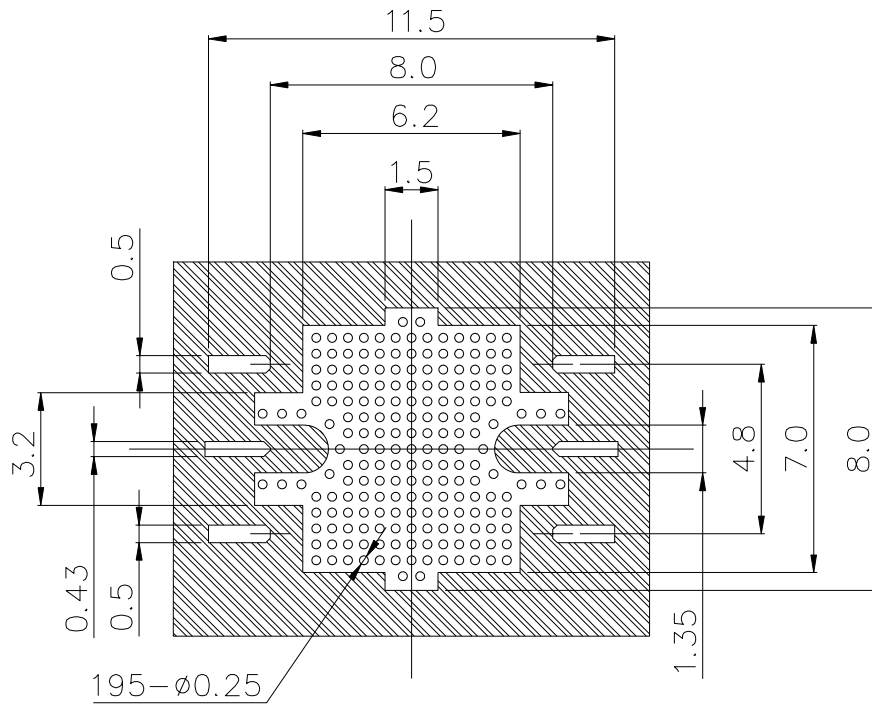

Notes :

1. LAMINATE : Rogers Corporation RO4003, Thickness $t=0.2\text{mm}$, Cu Foil $18\ \mu\text{m}$
 Finish to copper foil ; Ni $0.1\ \mu\text{m}$ min./Au $0.1\pm 0.08\ \mu\text{m}$ (Both side)
2.  : Resist

■ 4-inch Tray Packing (Part No. : EMM5832VU)

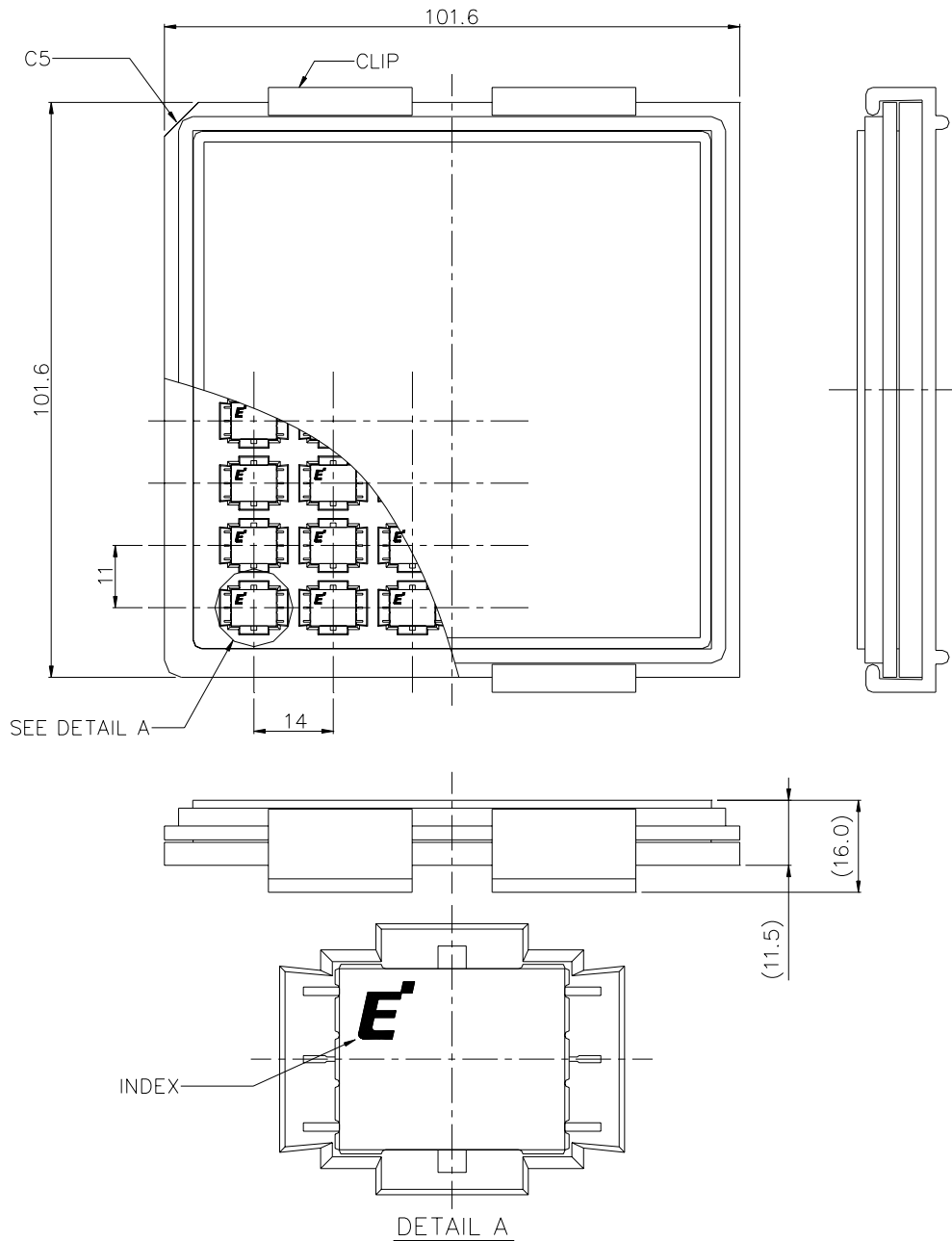

- (1) Maximum Quantity : 48 pcs./Tray
- (2) Tray Material : Conductive PS

■ Tape and Reel Packing (Part No. : EMM5832VUT)

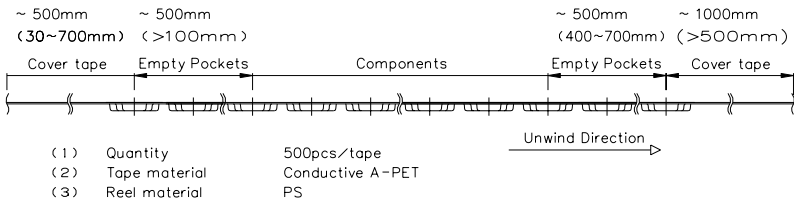
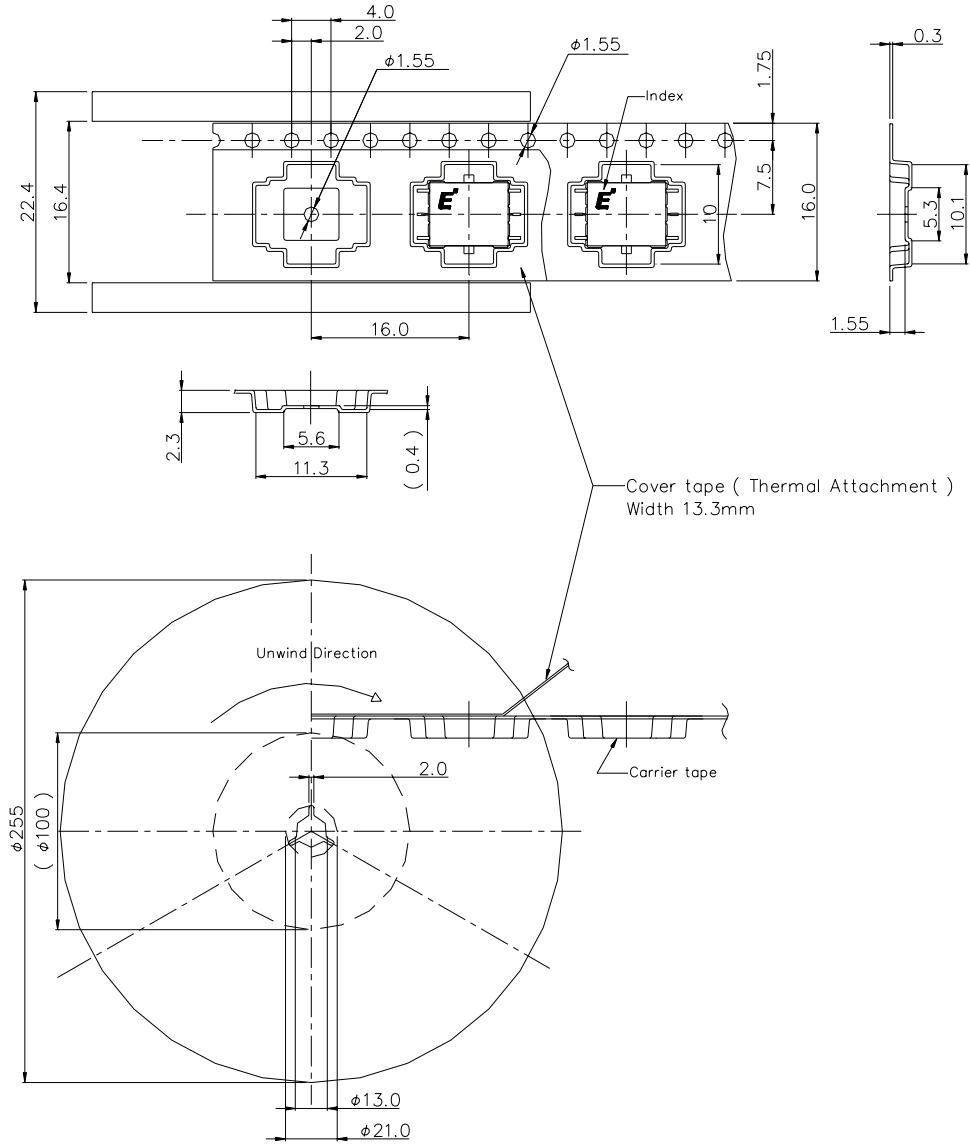



EMM5832VU
K-Band Power Amplifier MMIC

For further information please contact:

<http://global-sei.com/Electro-optic/about/office.html>

CAUTION

This product contains **gallium arsenide (GaAs)** which can be hazardous to the human body and the environment. For safety, observe the following procedures:

- Do not put these products into the mouth.
- Do not alter the form of this product into a gas, powder, or liquid through burning, crushing, or chemical processing as these by-products are dangerous to the human body if inhaled, ingested, or swallowed.
- Observe government laws and company regulations when discarding this product. This product must be discarded in accordance with methods specified by applicable hazardous waste procedures.