



# EMM5075VU

## Ku-Band Power Amplifier MMIC

### FEATURES

- High Output Power: Pout=33.0dBm (typ.)
- High Linear Gain: GL=26.0dB (typ.)
- Broad Band: 12.7~15.4GHz
- Impedance Matched Zin/Zout=50Ω
- Small Hermetic Metal-Ceramic SMT Package(VU)

### DESCRIPTION

The EMM5075VU is a MMIC amplifier that contains a three-stages amplifier, internally matched, for standard communications band in the 12.7 to 15.4GHz frequency range. SEDI's stringent Quality Assurance Program assures the highest reliability and consistent performance.



### ABSOLUTE MAXIMUM RATING

Item	Symbol	Rating	Unit
Drain-Source Voltage	V <sub>DD</sub>	10	V
Gate-Source Voltage	V <sub>GS</sub>	-3	V
Input Power	P <sub>in</sub>	26	dBm
Storage Temperature	T <sub>stg</sub>	-55 to +125	°C

### RECOMMENDED OPERATING CONDITIONS

Item	Symbol	Condition	Unit
Drain-Source Voltage	V <sub>DD</sub>	≤ 7	V
Input Power	P <sub>in</sub>	≤ 16	dBm
Operating Case Temperature	T <sub>C</sub>	-40 to +85	°C

### ELECTRICAL CHARACTERISTICS (Case Temperature Ta=25°C)

Item	Symbol	Test Conditions	Limits			Unit
			Min.	Typ.	Max.	
RF Frequency Range	f	V <sub>DD</sub> =+6V	12.7	-	15.4	GHz
Output Power at 1dB G.C.P.	P <sub>1dB</sub>	I <sub>DD(DC)</sub> =1200mA typ.	32	33	-	dBm
Power Gain at 1dB G.C.P.	G <sub>1dB</sub>	Z <sub>S</sub> =Z <sub>L</sub> =50ohm	20	25	-	dB
Power-added Efficiency at 1dB G.C.P.	η <sub>add</sub>		-	25	-	%
Drain Current at 1dB G.C.P.	I <sub>DDRF</sub>		-	1500	1800	mA
3rd. Order Intermodulation Distortion *	IM <sub>3</sub>	* df=+10MHz	-38	-44	-	dBc
Input Return Loss (at Pin=-20dBm)	RL <sub>IN</sub>	P <sub>o</sub> =20dBm S.C.L	-	-8	-	dB
Output Return Loss (at Pin=-20dBm)	RL <sub>OUT</sub>		-	-8	-	dB

G.C.P. : Gain Compression Point, SCL : Single Carrier Level

<b>ESD</b>	<b>Class 0</b>	<b>~ 250V</b>
------------	----------------	---------------

Note : Based on JEDEC JESD22-A114C

<b>CASE STYLE</b>	<b>VU</b>
-------------------	-----------

<b>RoHs Compliance</b>	<b>Yes</b>
------------------------	------------

### ORDERING INFORMATION

Part Number	Order Unit	Packing
EMM5075VU	No Limitation	48 pcs./Tray × 4 Tray = 192 pcs./Packing
EMM5075VUT	500pcs.	500 pcs./Reel × 1 Reel = 500 pcs./Packing



# EMM5075VU

## Ku-Band Power Amplifier MMIC

### OUTPUT POWER vs. FREQUENCY

@VDD=6V, IDD(DC)=1200mA

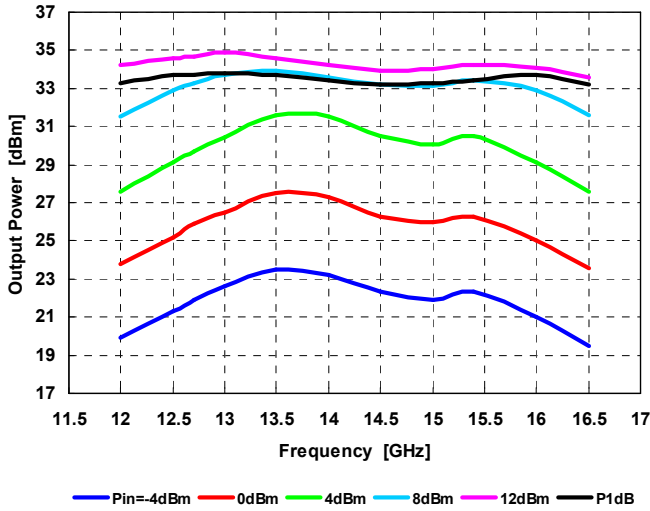

### OUTPUT POWER, DRAIN CURRENT vs. INPUT POWER

@VDD=6V, IDD(DC)=1200mA

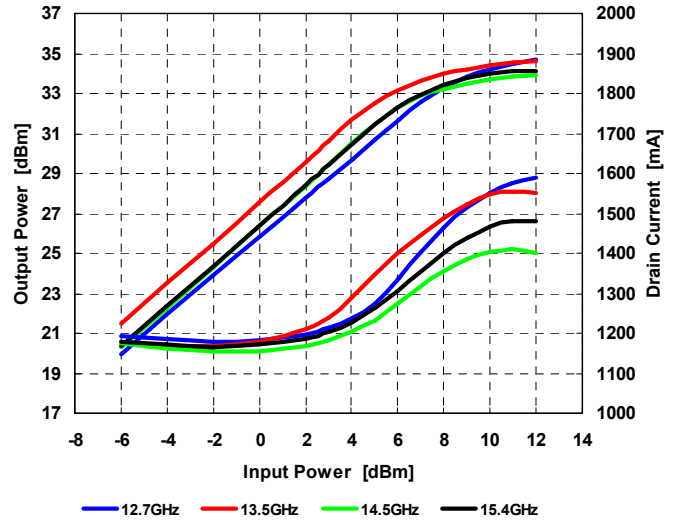

### POWER-ADDED EFFICIENCY vs FREQUENCY

@VDD=6V, IDD(DC)=1200mA

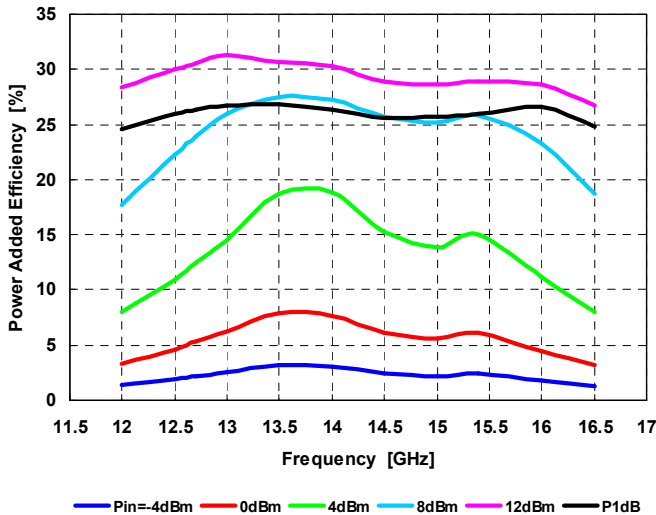



# EMM5075VU

## Ku-Band Power Amplifier MMIC

### IMD vs. FREQUENCY

@VDD=6V, IDD(DC)=1200mA, Pout=20dBm S.C.L.

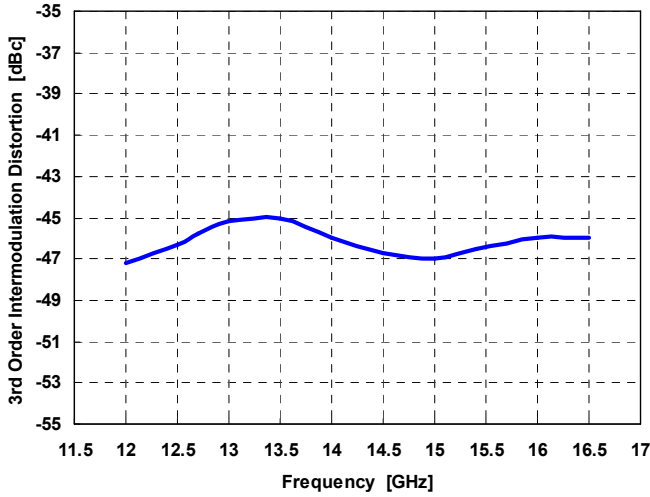

### IMD vs OUTPUT POWER

@VDD=6V, IDD(DC)=1200mA

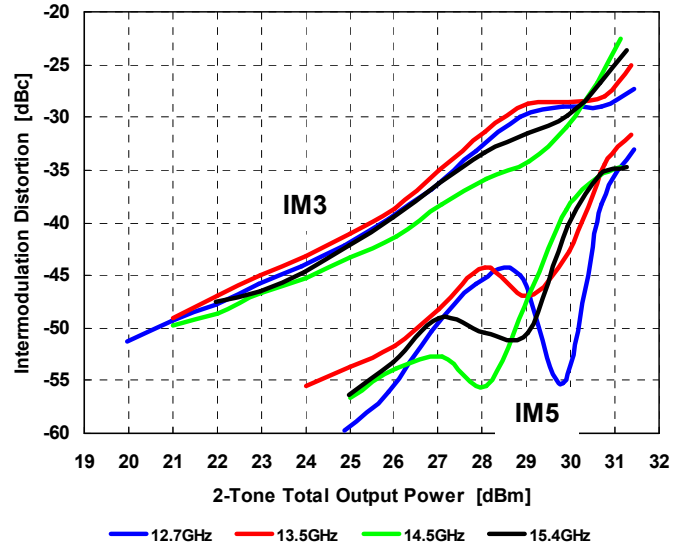

### P1dB, G1dB vs. Frequency by Drain Voltage

IDD(DC)=1200mA

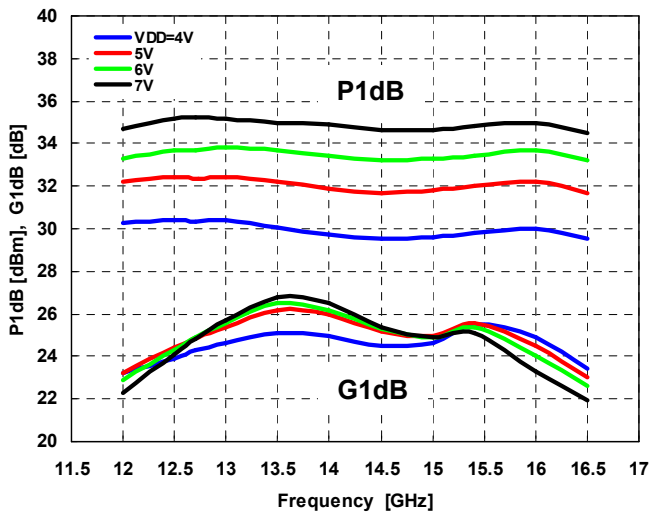

### P1dB, G1dB vs. Frequency by Drain Current

@VDD=6V

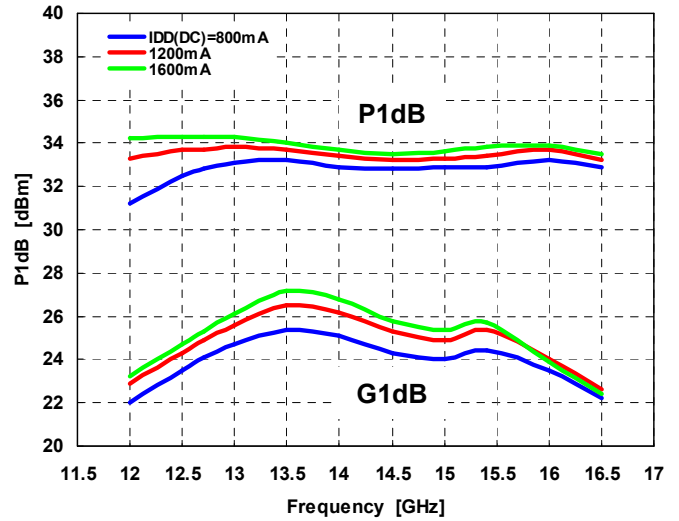



# EMM5075VU

## Ku-Band Power Amplifier MMIC

OUTPUT POWER, DRAIN CURRENT vs. INPUT POWER by Drain Voltage

@IDD(DC)=1200mA, f=12.7GHz

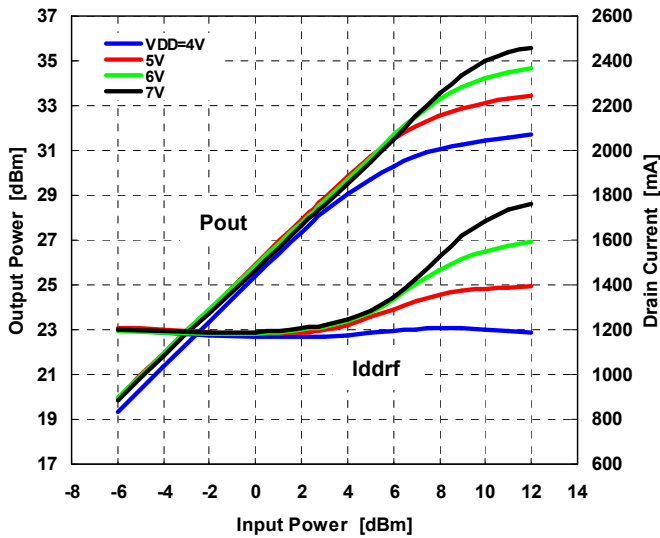

OUTPUT POWER, DRAIN CURRENT vs. INPUT POWER by Drain Voltage

@IDD(DC)=1200mA, f=13.5GHz

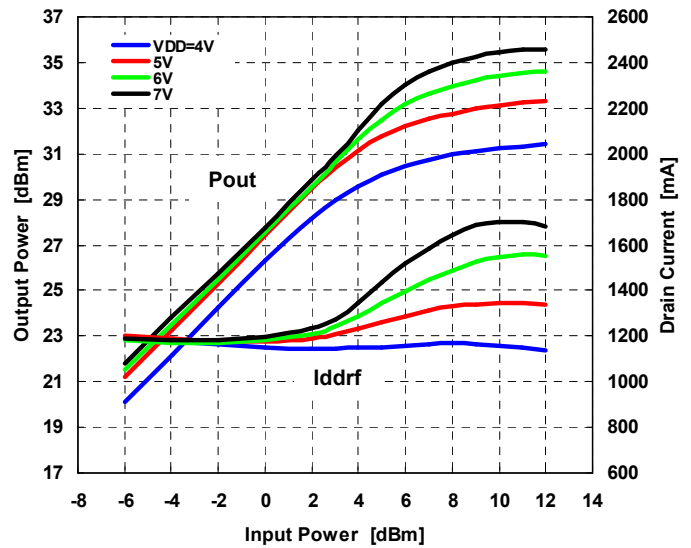

OUTPUT POWER, DRAIN CURRENT vs. INPUT POWER by Drain Voltage

@IDD(DC)=1200mA, f=14.5GHz

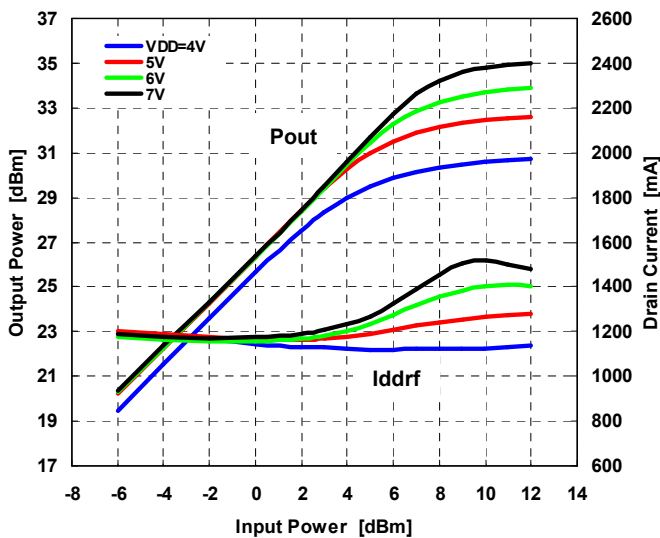

OUTPUT POWER, DRAIN CURRENT vs. INPUT POWER by Drain Voltage

@IDD(DC)=1200mA, f=15.4GHz

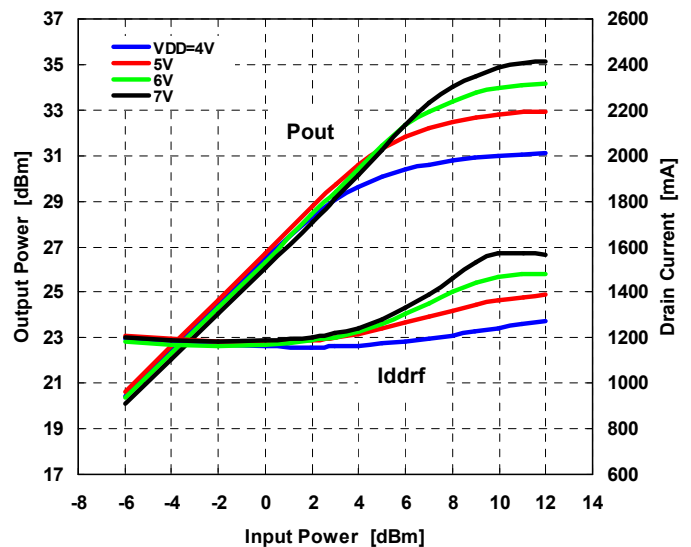

**OUTPUT POWER, DRAIN CURRENT vs. INPUT POWER by Drain Current**

@VDD=6V, f=12.7GHz

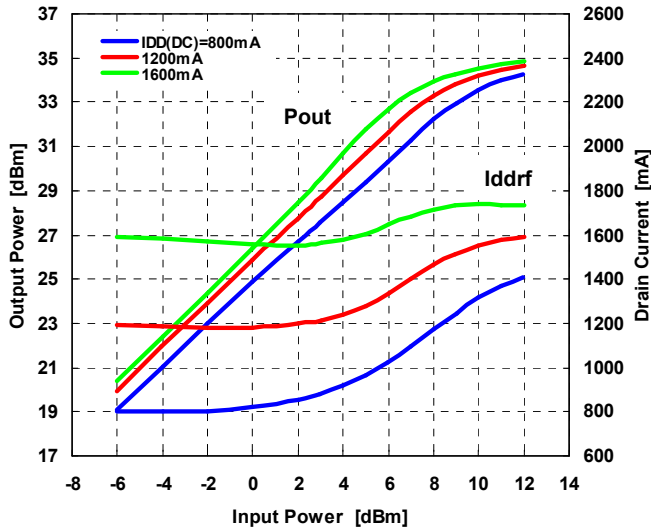

**OUTPUT POWER, DRAIN CURRENT vs. INPUT POWER by Drain Current**

@VDD=6V, f=13.5GHz

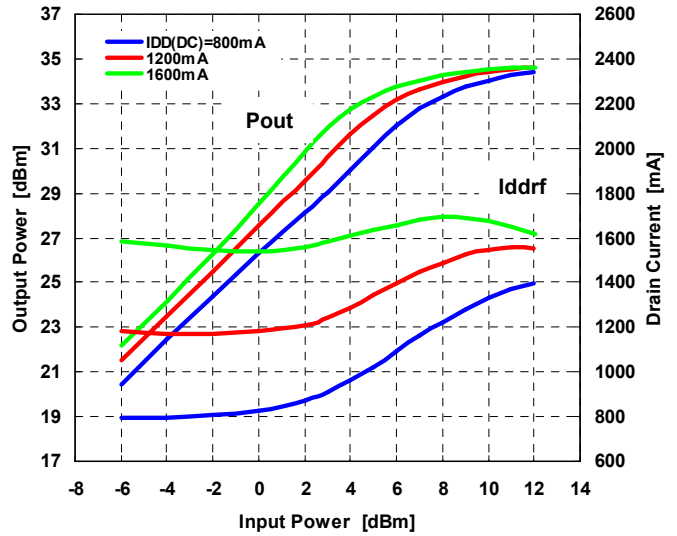

**OUTPUT POWER, DRAIN CURRENT vs. INPUT POWER by Drain Current**

@VDD=6V, f=14.5GHz

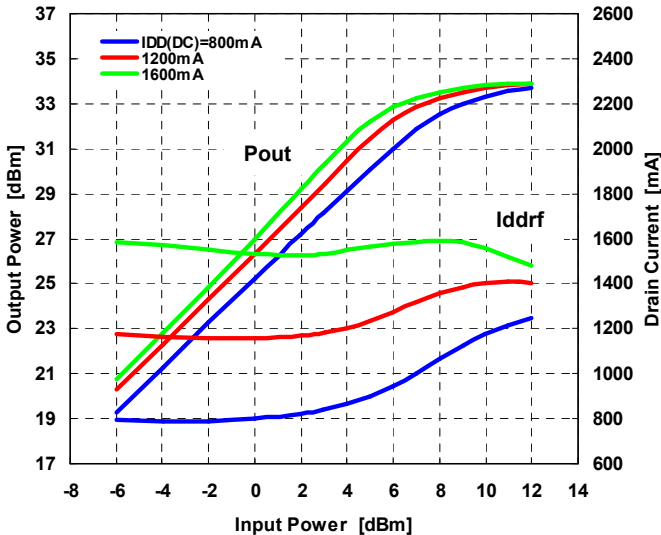

**OUTPUT POWER, DRAIN CURRENT vs. INPUT POWER by Drain Current**

@VDD=6V, f=15.4GHz

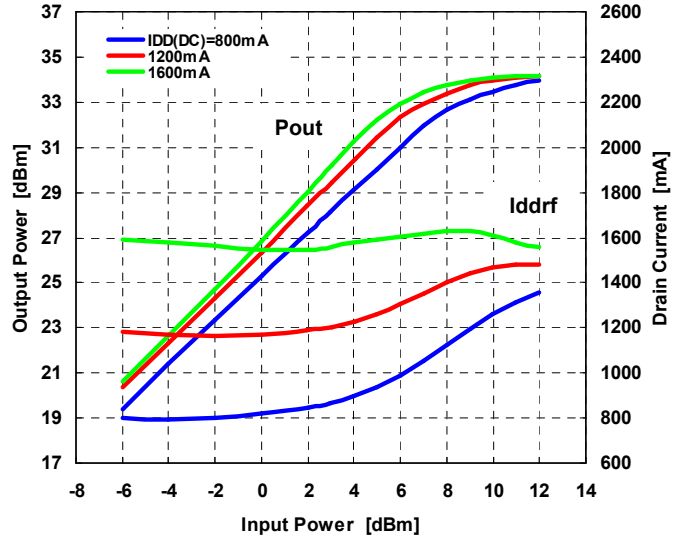



# EMM5075VU

## Ku-Band Power Amplifier MMIC

### IMD PERFORMANCE vs. OUTPUT POWER by Drain Voltage

@IDD(DC)=1200mA, f=12.7GHz

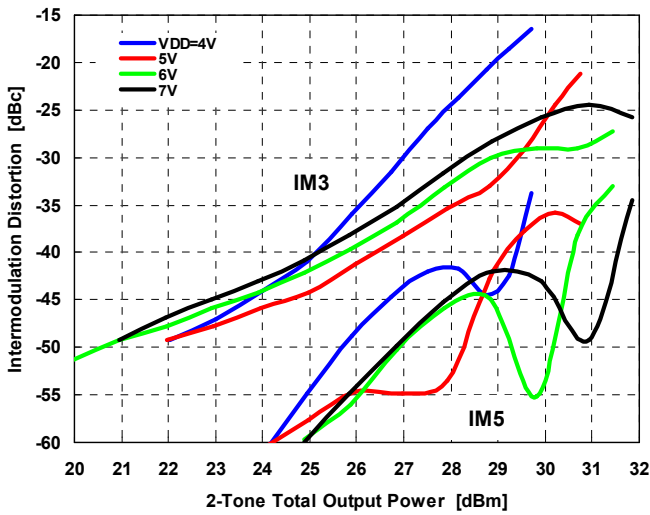

### IMD PERFORMANCE vs. OUTPUT POWER by Drain Voltage

@IDD(DC)=1200mA, f=13.5GHz

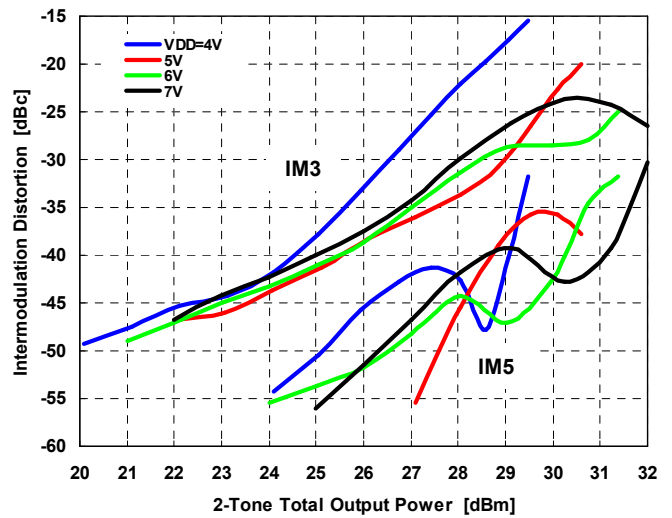

### IMD PERFORMANCE vs. OUTPUT POWER by Drain Voltage

@IDD(DC)=1200mA, f=14.5GHz

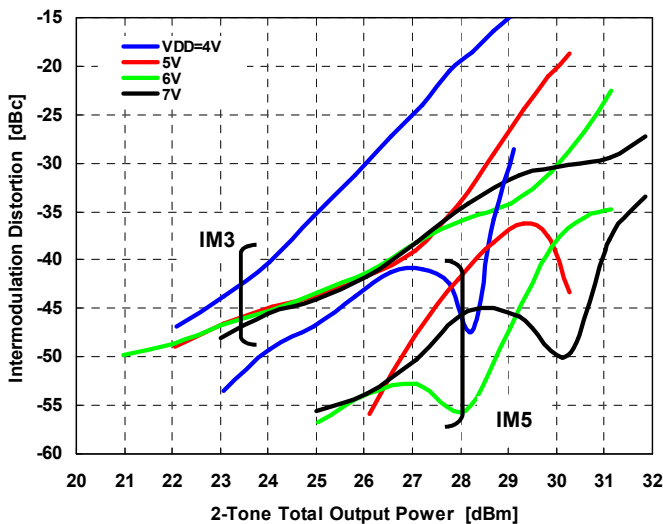

### IMD PERFORMANCE vs. OUTPUT POWER by Drain Voltage

@IDD(DC)=1200mA, f=15.4GHz

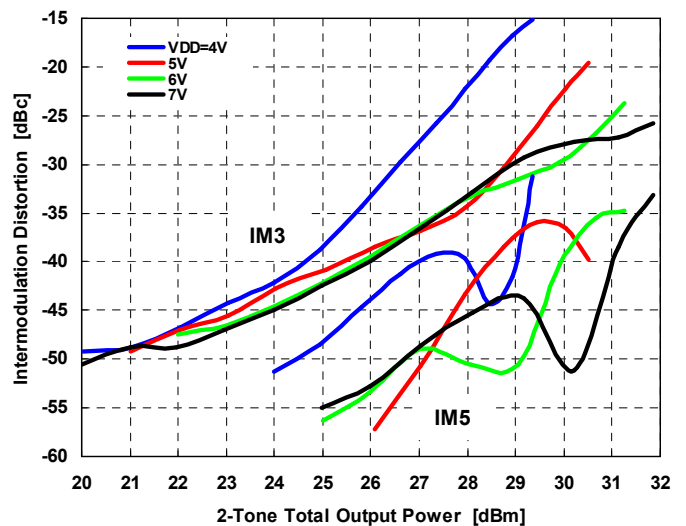



# EMM5075VU

## Ku-Band Power Amplifier MMIC

### IMD PERFORMANCE vs. OUTPUT POWER by Drain Current

@VDD=6V, f=12.7GHz

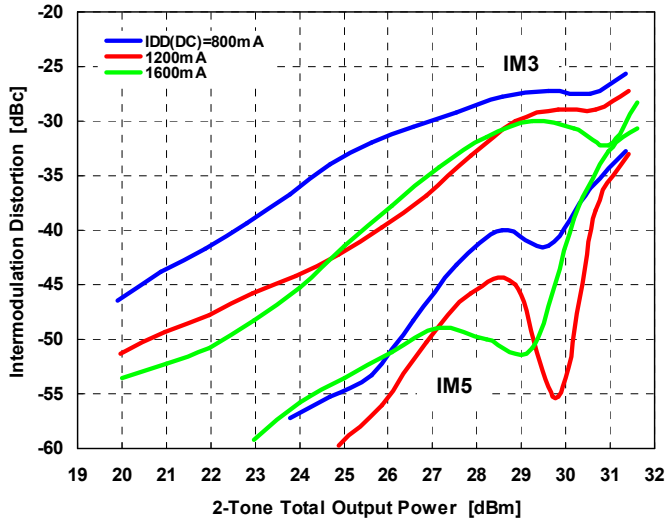

### IMD PERFORMANCE vs. OUTPUT POWER by Drain Current

@VDD=6V, f=13.5GHz

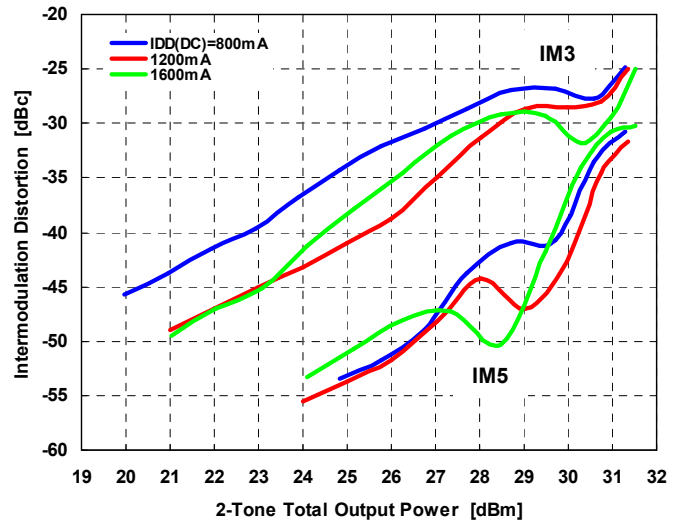

### IMD PERFORMANCE vs. OUTPUT POWER by Drain Current

@VDD=6V, f=14.5GHz

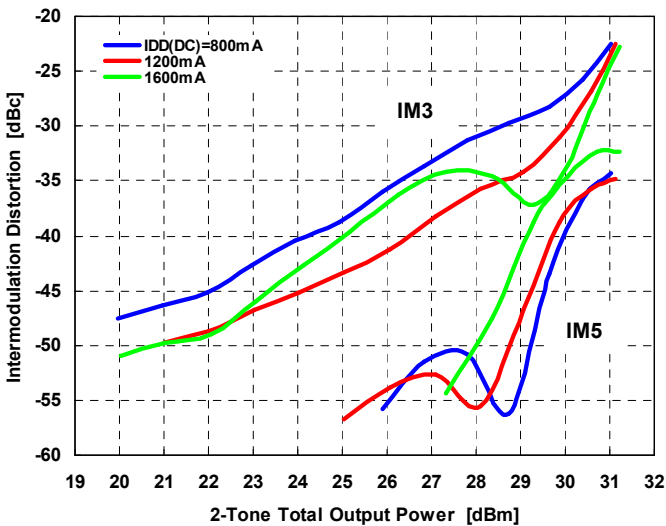

### IMD PERFORMANCE vs. OUTPUT POWER by Drain Current

@VDD=6V, f=15.4GHz

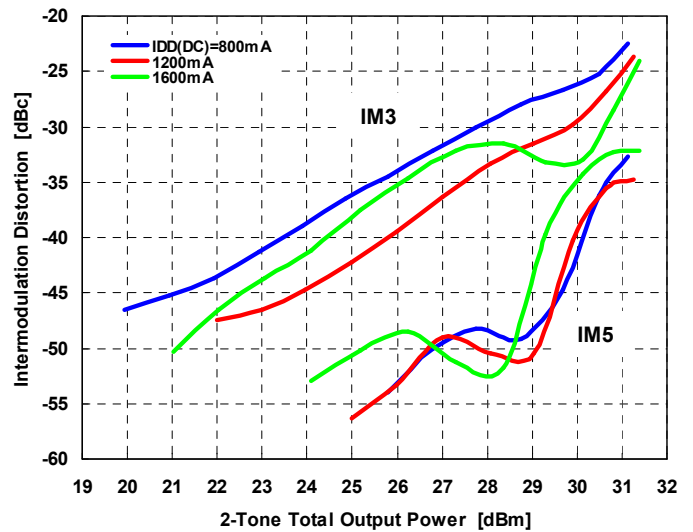



# EMM5075VU

## Ku-Band Power Amplifier MMIC

**OUTPUT POWER, DRAIN CURRENT vs. INPUT POWER by Temperature**

@VDD=6V, IDD(DC)=1200mA(Ta=+25deg.), Freq.=12.7GHz

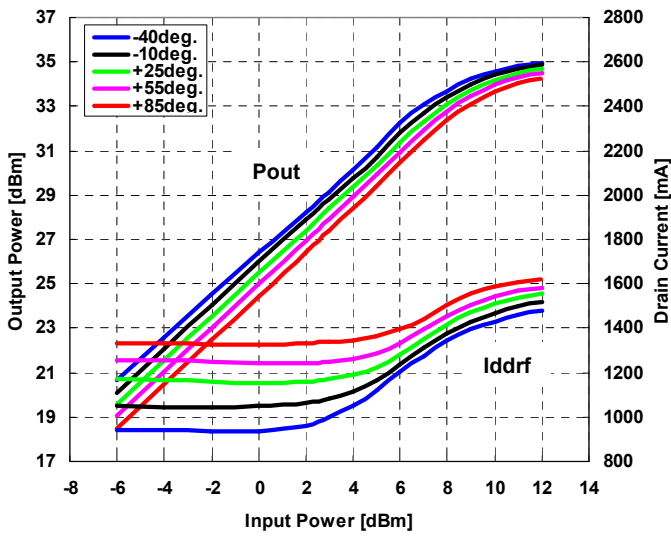

**OUTPUT POWER, DRAIN CURRENT vs. INPUT POWER by Temperature**

@VDD=6V, IDD(DC)=1200mA(Ta=+25deg.), Freq.=13.5GHz

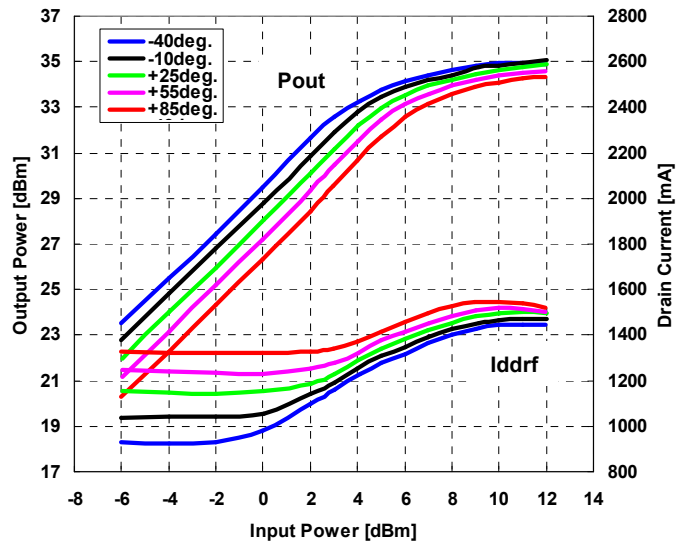

**OUTPUT POWER, DRAIN CURRENT vs. INPUT POWER by Temperature**

@VDD=6V, IDD(DC)=1200mA(Ta=+25deg.), Freq.=14.5GHz

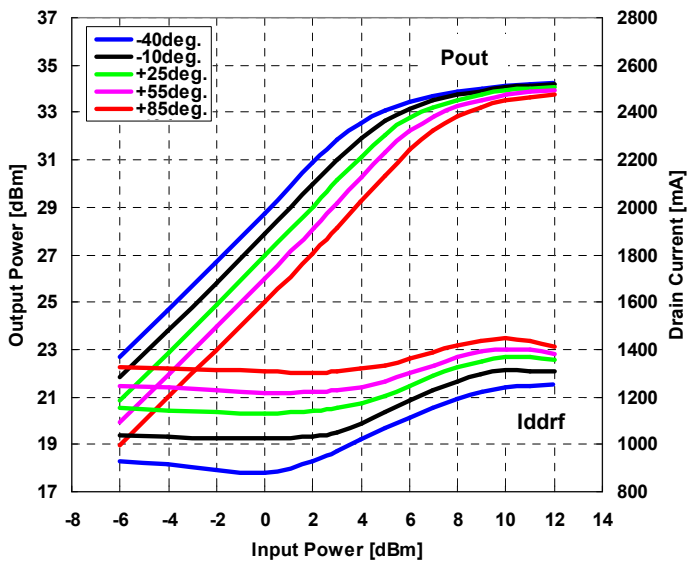

**OUTPUT POWER, DRAIN CURRENT vs. INPUT POWER by Temperature**

@VDD=6V, IDD(DC)=1200mA(Ta=+25deg.), Freq.=15.4GHz

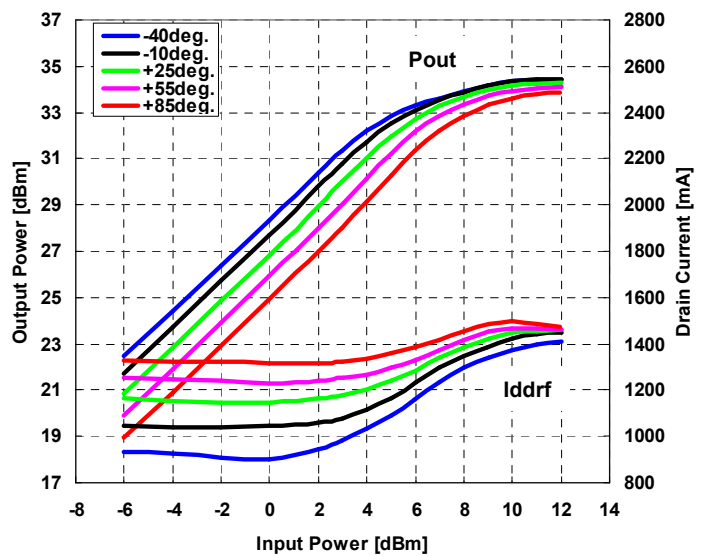

### IMD PERFORMANCE vs. OUTPUT POWER by Temperature

@VDD=6V, IDD(DC)=1200mA(Ta=+25deg.), Freq.=12.7GHz

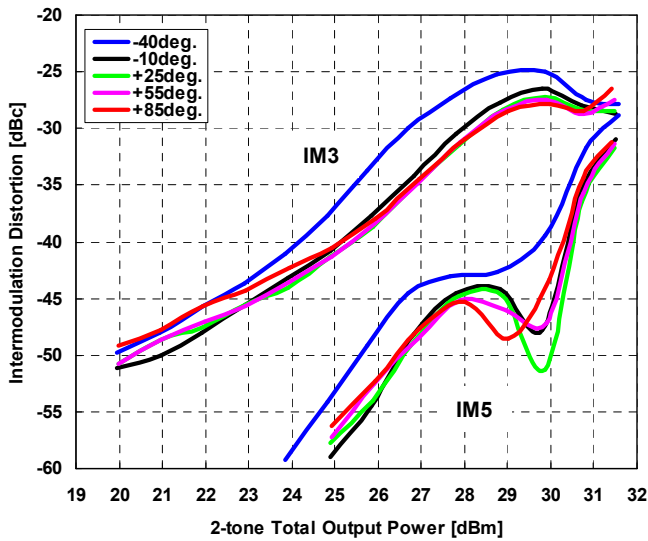

### IMD PERFORMANCE vs. OUTPUT POWER by Temperature

@VDD=6V, IDD(DC)=1200mA(Ta=+25deg.), Freq.=13.5GHz

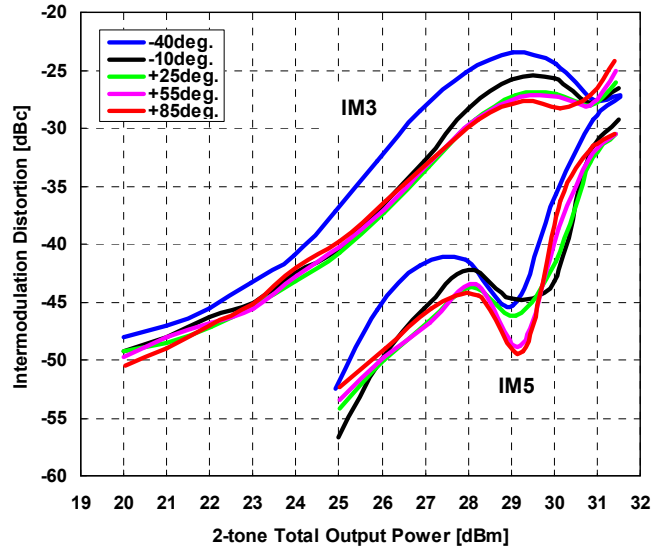

### IMD PERFORMANCE vs. OUTPUT POWER by Temperature

@VDD=6V, IDD(DC)=1200mA(Ta=+25deg.), Freq.=14.5GHz

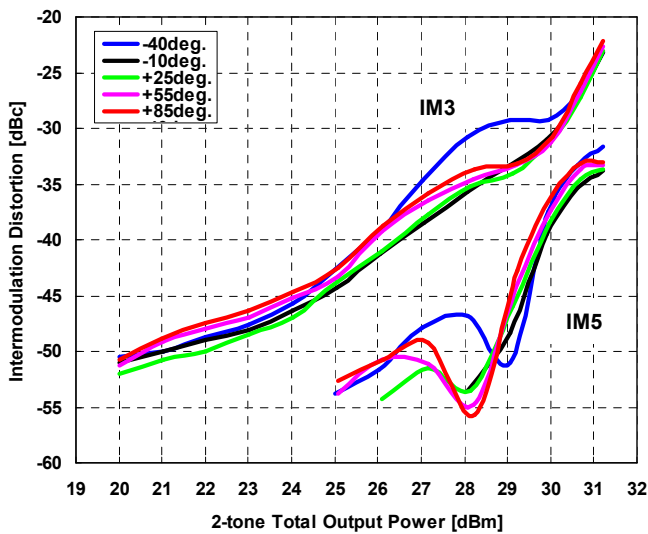

### IMD PERFORMANCE vs. OUTPUT POWER by Temperature

@VDD=6V, IDD(DC)=1200mA(Ta=+25deg.), Freq.=15.4GHz

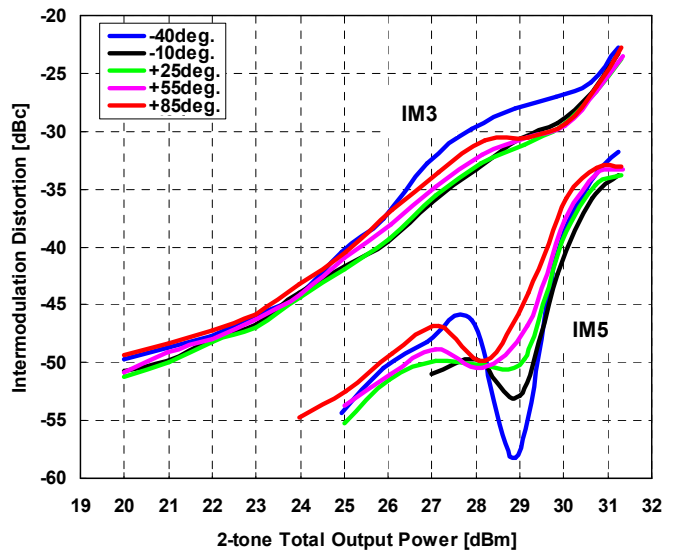



# EMM5075VU

## Ku-Band Power Amplifier MMIC

### ■ S-PARAMETER

VDD=6V, IDD(DC)=1200mA

Frequency [GHz]	S11		S21		S12		S22	
	MAG	ANG	MAG	ANG	MAG	ANG	MAG	ANG
1.0	0.98	-31.4	0.07	10.1	0.00	148.6	0.97	-43.8
2.0	0.94	-63.4	0.23	-151.6	0.00	-147.9	0.91	-85.9
3.0	0.92	-91.4	0.34	92.9	0.00	-162.8	0.91	-123.0
4.0	0.94	-115.1	0.24	-1.9	0.00	160.8	0.93	-157.1
5.0	0.92	-138.3	0.12	-55.7	0.00	114.8	0.89	163.4
6.0	0.89	-165.3	0.07	-61.7	0.00	65.9	0.82	111.5
7.0	0.86	159.5	0.15	37.2	0.00	6.2	0.82	60.6
8.0	0.80	125.0	5.49	-72.1	0.00	-84.6	0.78	14.7
9.0	0.79	92.0	7.76	122.2	0.00	-127.2	0.61	-46.8
10.0	0.77	53.2	9.14	19.2	0.00	-138.8	0.50	-115.3
11.0	0.76	7.8	11.88	-78.8	0.00	-162.2	0.25	-155.6
12.0	0.79	-28.4	15.33	-179.5	0.00	-116.3	0.15	-47.7
12.2	0.79	-34.5	16.08	160.0	0.00	-105.6	0.20	-47.1
12.4	0.77	-39.5	16.90	139.3	0.00	-97.6	0.23	-48.4
12.6	0.76	-44.0	17.77	118.3	0.00	-103.2	0.26	-49.7
12.8	0.74	-48.3	18.64	97.1	0.00	-105.2	0.27	-50.1
13.0	0.73	-51.9	19.81	75.9	0.00	-114.8	0.28	-49.7
13.2	0.73	-56.9	21.23	53.4	0.00	-127.9	0.29	-50.9
13.4	0.74	-64.6	22.75	28.4	0.00	-146.6	0.31	-57.3
13.6	0.64	-77.2	22.65	1.0	0.00	170.4	0.26	-72.2
13.8	0.55	-78.3	22.27	-21.7	0.00	-170.9	0.21	-66.7
14.0	0.50	-85.0	22.05	-46.9	0.00	-156.1	0.18	-72.5
14.2	0.42	-91.1	21.10	-70.5	0.00	-163.2	0.13	-80.5
14.4	0.35	-95.3	20.19	-93.0	0.00	-161.3	0.08	-88.4
14.6	0.29	-98.2	19.50	-114.5	0.00	-162.0	0.03	-102.1
14.8	0.24	-103.5	19.06	-136.2	0.00	-158.6	0.03	104.6
15.0	0.18	-104.1	19.00	-157.4	0.00	-159.6	0.08	81.7
15.2	0.15	-99.8	19.42	-180.0	0.00	-157.1	0.12	67.1
15.4	0.14	-97.7	19.92	154.7	0.00	-156.7	0.16	51.7
15.6	0.15	-101.4	20.04	127.5	0.00	-159.4	0.16	31.3
15.8	0.16	-116.3	18.96	98.8	0.00	-168.2	0.13	5.9
16.0	0.16	-139.8	16.92	71.9	0.00	-176.1	0.08	-24.6
16.2	0.15	-170.2	15.17	48.4	0.00	179.7	0.02	-70.7
16.4	0.15	154.4	14.31	26.0	0.01	171.8	0.02	163.1
16.6	0.15	111.0	14.09	1.2	0.01	168.7	0.02	122.4
16.8	0.20	68.9	13.80	-27.7	0.01	160.2	0.01	-40.0
17.0	0.27	33.1	12.88	-59.9	0.01	151.0	0.07	-85.9
18.0	0.57	-56.0	3.97	157.9	0.00	131.8	0.30	-161.4
19.0	0.67	-87.2	1.05	54.6	0.01	92.1	0.19	132.6
20.0	0.63	-108.3	0.30	-35.1	0.00	43.6	0.37	2.2
21.0	0.44	-150.9	0.09	-121.3	0.00	172.3	0.61	-32.0
22.0	0.38	119.9	0.02	145.1	0.01	47.1	0.66	-55.1
23.0	0.42	50.3	0.01	-13.0	0.01	-41.5	0.63	-104.1
24.0	0.44	-36.6	0.01	-119.4	0.01	-122.6	0.71	-159.7
25.0	0.60	-100.2	0.01	148.1	0.01	149.3	0.76	177.9
26.0	0.69	-125.3	0.01	3.2	0.01	-0.1	0.75	169.1
27.0	0.69	-150.0	0.00	14.8	0.00	-100.2	0.71	157.3
28.0	0.65	173.7	0.01	-19.9	0.01	-19.4	0.70	138.5
29.0	0.64	127.2	0.01	-131.8	0.01	-136.7	0.55	109.1
30.0	0.63	72.0	0.01	176.4	0.00	-175.6	0.42	98.2
31.0	0.57	19.4	0.01	119.7	0.01	123.3	0.51	85.5
32.0	0.52	-45.9	0.00	2.3	0.00	5.9	0.68	67.2
33.0	0.53	-114.4	0.00	-119.1	0.00	-111.2	0.73	44.4
34.0	0.60	-146.9	0.01	161.4	0.01	166.6	0.60	8.2
35.0	0.64	-167.2	0.01	58.5	0.02	60.4	0.59	-50.3
36.0	0.61	158.7	0.02	-8.5	0.02	-9.4	0.64	-82.6
37.0	0.66	111.5	0.02	-87.3	0.02	-87.7	0.56	-101.4
38.0	0.73	70.6	0.00	85.6	0.01	130.1	0.30	166.7
39.0	0.70	48.1	0.02	-75.8	0.02	-74.8	0.40	70.6
40.0	0.63	28.1	0.02	175.2	0.02	174.3	0.42	42.8





# EMM5075VU

Ku-Band Power Amplifier MMIC

## S-PARAMETER

VDD=6V, IDD(DC)=1200mA

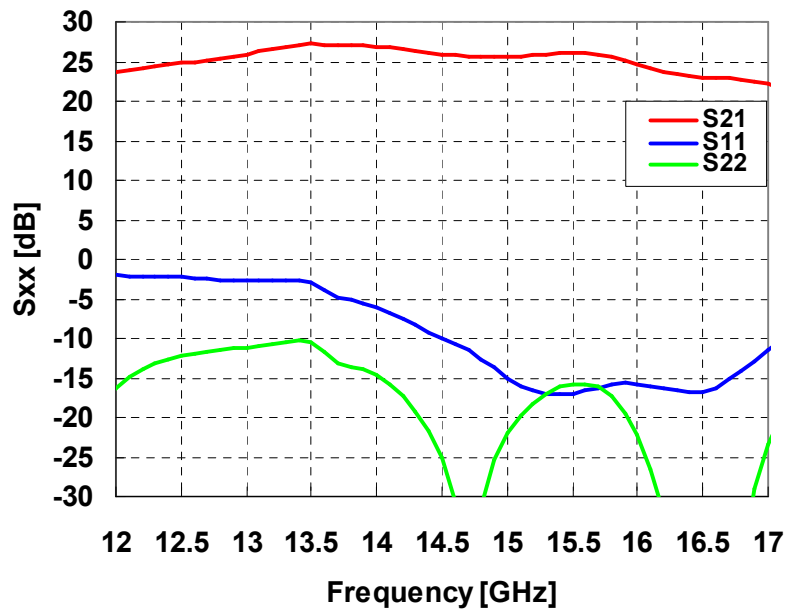
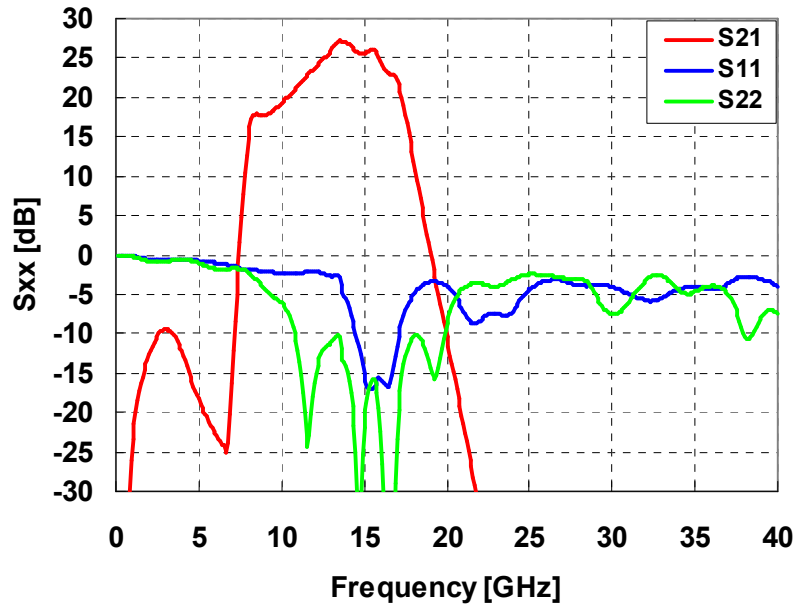



# EMM5075VU

Ku-Band Power Amplifier MMIC

$\Delta T_{ch}$  vs. Drain Voltage  
(Reference)

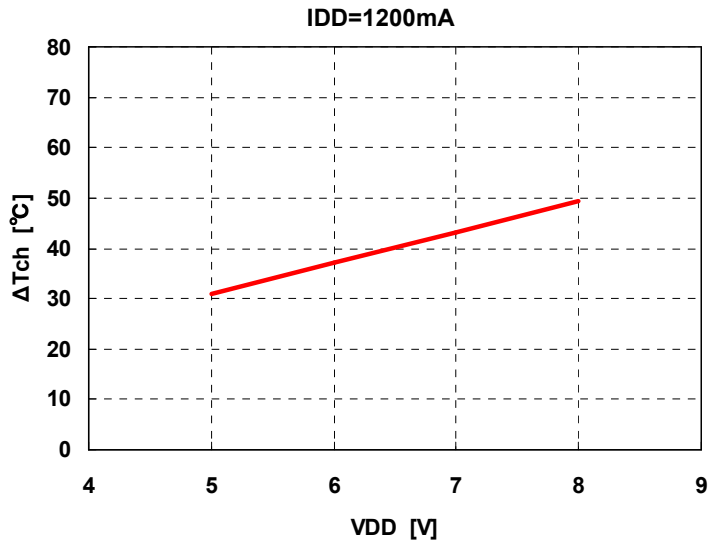

Note:  $\Delta T_{ch}$  : Temperature Rise from Backside of the Package to Channel.

MTTF vs. T<sub>ch</sub>

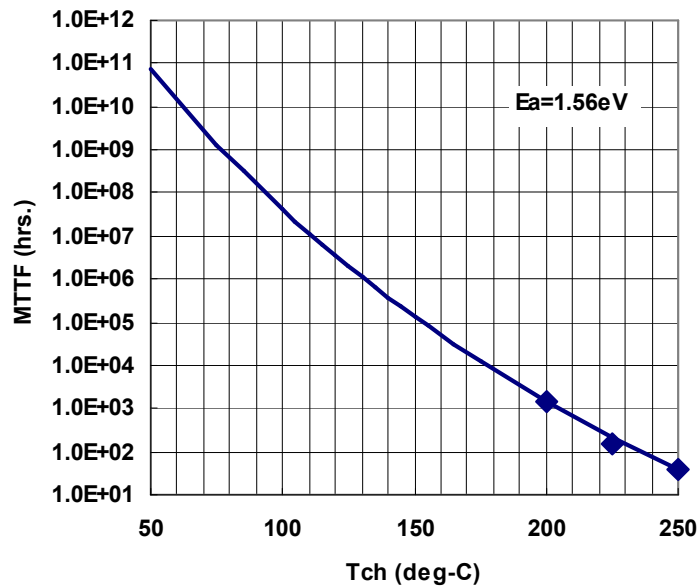

■ Block diagram

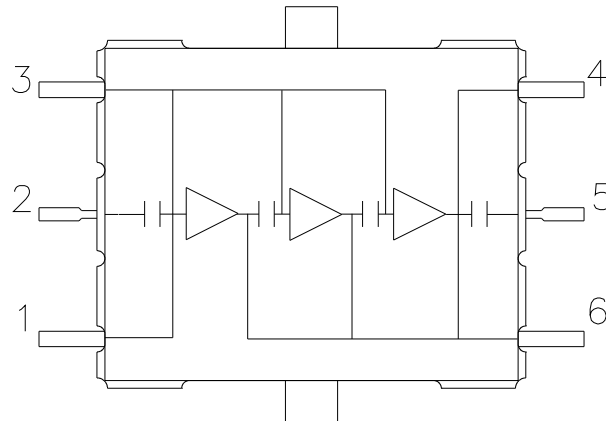

PIN ASSIGNMENT

- 1 : VGG
- 2 : RF in
- 3 : VGG
- 4 : VDD
- 5 : RF out
- 6 : VDD

■ Recommended Bias Circuit

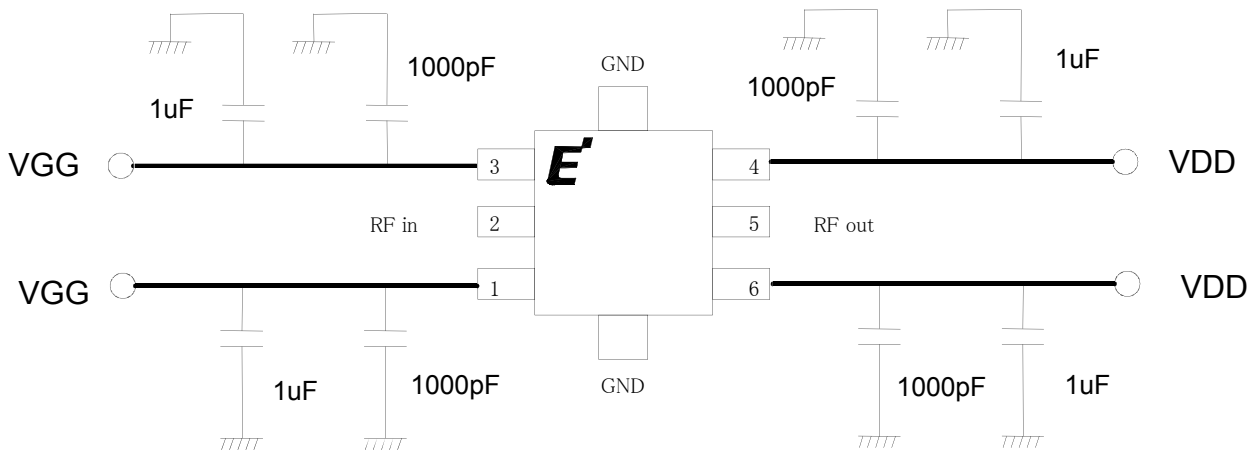

Note 1: The capacitors are recommended on the bias supply line, close to the package, in order to prevent video oscillations which could damage the module.

Note 2: Two pins named VGG are internally connected.

Note 3: Two pins named VDD are internally connected.



# EMM5075VU

Ku-Band Power Amplifier MMIC

■ Package Outline

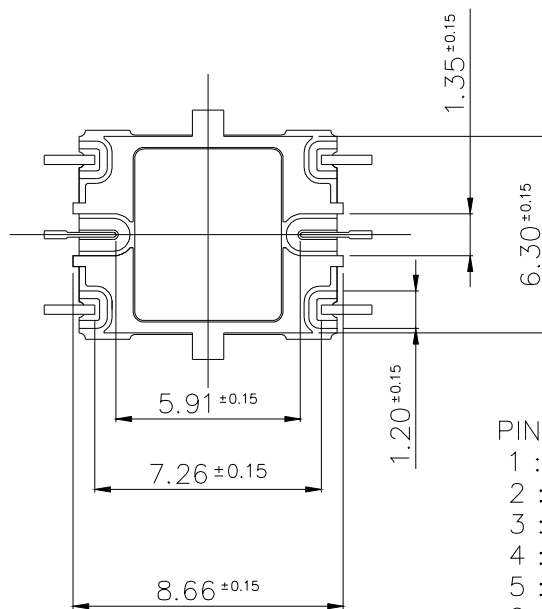
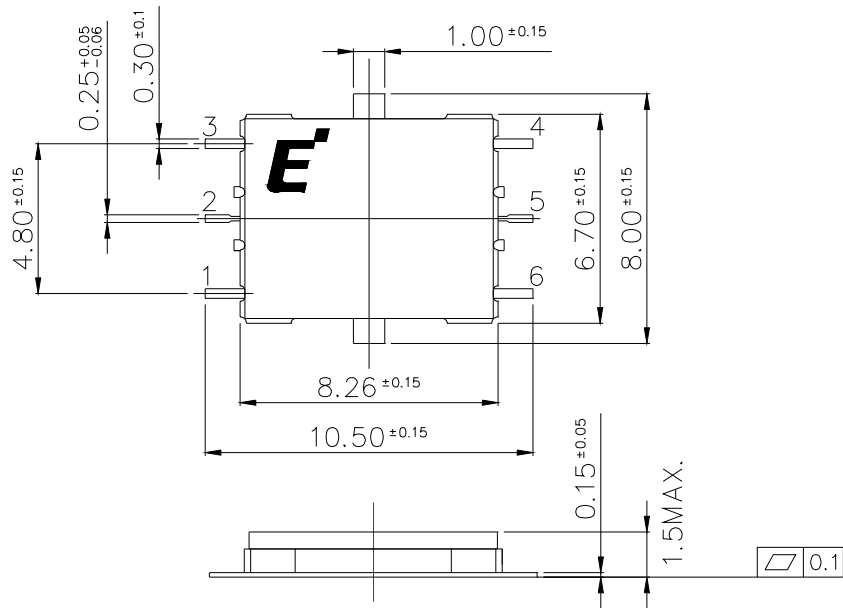

PIN Assignments

- 1 : VGG
- 2 : RF in
- 3 : VGG
- 4 : VDD
- 5 : RF out
- 6 : VDD

Flange : GND  
Unit : mm

■ PCB Pads and Solder-resist Pattern

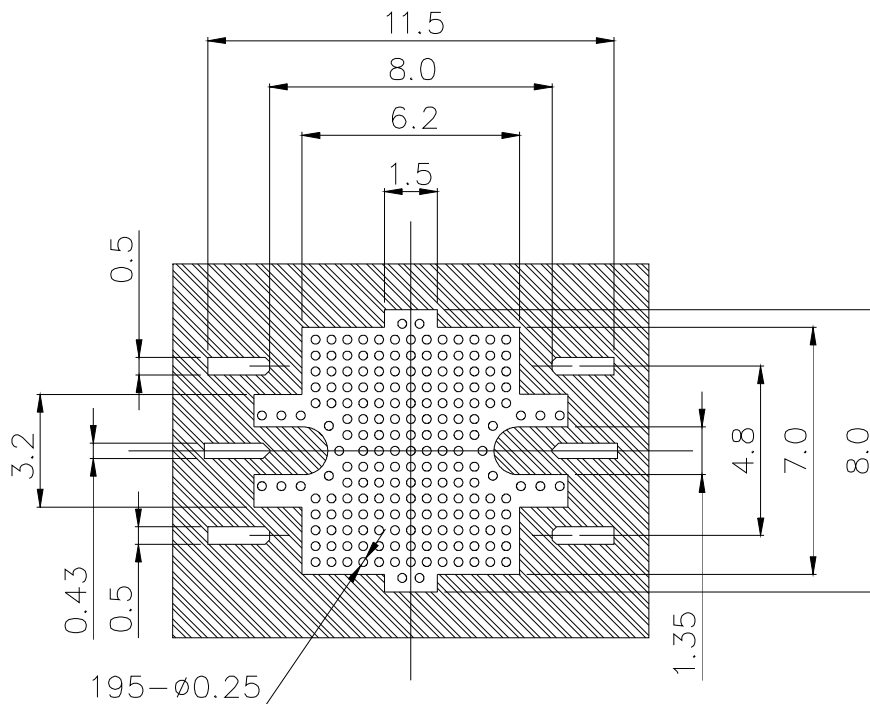

Notes :

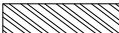
1. LAMINATE : Rogers Corporation RO4003, Thickness  $t=0.2\text{mm}$ , Cu Foil  $18\mu\text{m}$   
 Finish to copper foil ; Ni  $0.1\mu\text{m}$  min./Au  $0.1\pm 0.08\mu\text{m}$  (Both side)
2.  : Resist



# EMM5075VU

Ku-Band Power Amplifier MMIC

## 4-inch Tray Packing (Part No. : EMM5075VU)

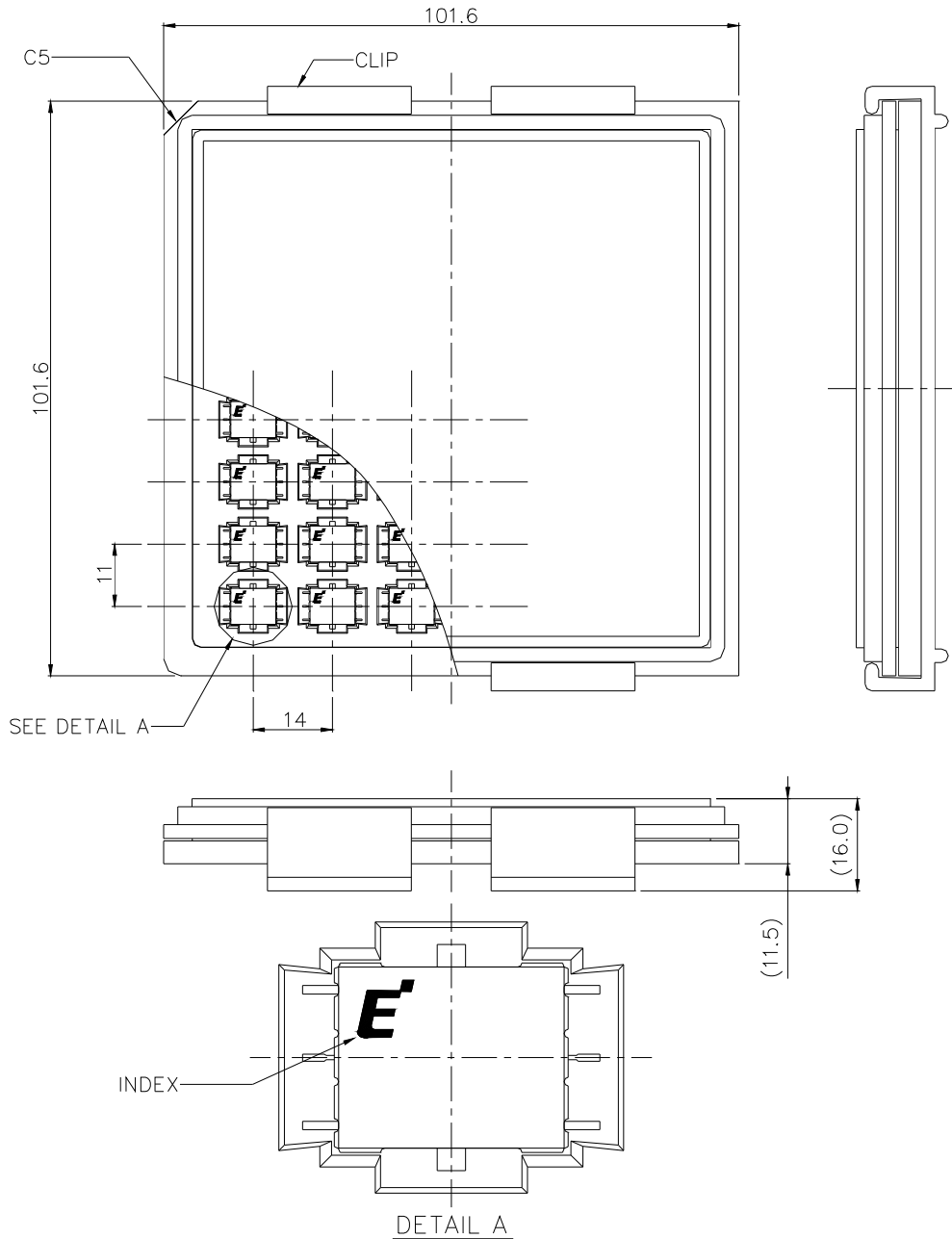

- (1) Maximum Quantity : 48 pcs./Tray
- (2) Tray Material : Conductive PS

### ■ Tape and Reel Packing (Part No. : EMM5075VUT)

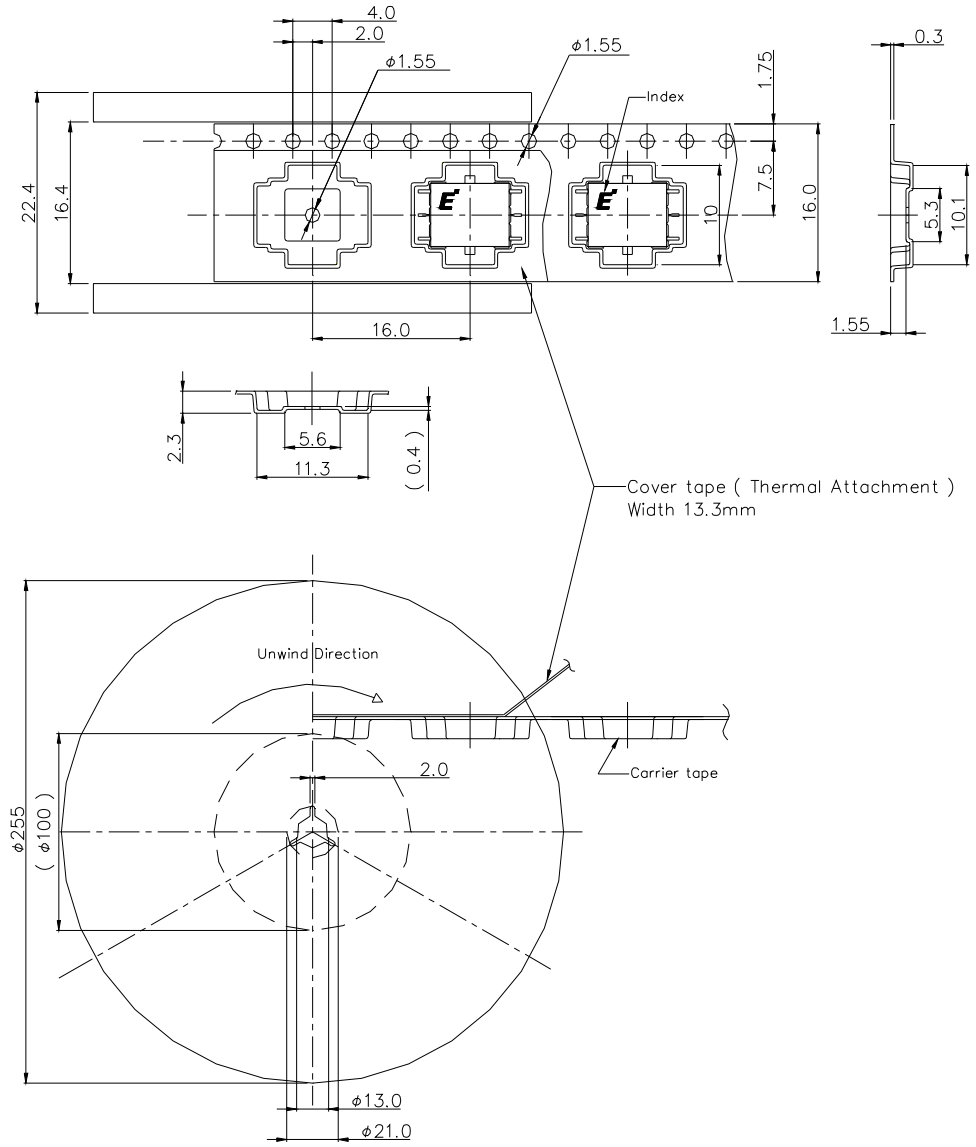

Cover tape ( Thermal Attachment )  
Width 13.3mm

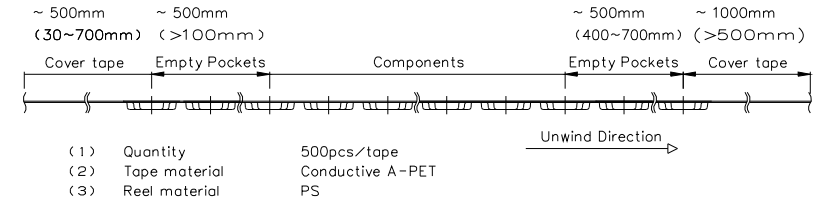

### ■ Mounting Method of SMD(Surface Mount Devices) for Lead-free solder

#### Mounting Condition

1. For soldering, Lead-free solder (Sn-3.0Ag-0.5Cu)\*<sup>1</sup> or equivalent shall be used.  
(\*1:The figure displays with weight %. A predominantly tin-rich alloy with 3.0% silver and 0.5% copper.)
2. A rosin type flux with a chlorine content of 0.2% or less shall be used. The rosin flux with low halogen content is recommended.
3. When soldering, use one of the following time/ temperature methods for acceptable solder joints. Make sure the devices have been properly prepared with flux prior soldering.

#### \* Reflow soldering method (Infrared reflow / Heat circulation reflow / Hot plate reflow):

Limit solder to 3 reflow cycles because resin is used in the modules manufacturing process. Excessive reflow cycles will effect the resin resulting in a potential failure or latent defect. The recommended reflow temperature profile is shown below. The temperature of the reflow profile must be measured at the device lead.

#### Reflow temperature profile and condition:

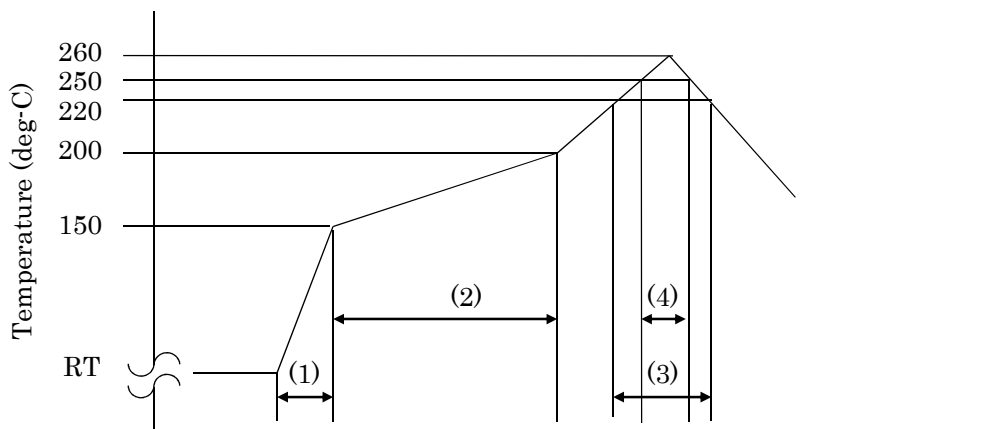

Condition	Temperature	Time
(1) Average Ramp-up Rate:	3deg-C/seconds	
(2) Preheating:	150 - 200deg-C,	60 - 180seconds
(3) Main heating:	220deg-C,	60seconds max.
(4) Peak Temperature:	260deg-C max., more than 250deg-C,	10 seconds max.

\* Measurement point: Device lead.

4. The above-recommended conditions were confirmed using the manufacture's equipment and materials. However, when soldering these products, the soldering condition should be verified by customer using their equipment and materials.



# EMM5075VU

## Ku-Band Power Amplifier MMIC

For further information please contact :

**Sumitomo Electric Device Innovations,  
U.S.A., Inc.**

2355 Zanker Rd.  
San Jose, CA 95131-1138, U.S.A.  
TEL: +1 408 232-9500  
FAX: +1 408 428-9111

**Sumitomo Electric Europe Ltd.**

220 Centennial Park,  
Elstree WD6 3SL United Kingdom  
TEL: +44 (0)20 89538118  
FAX: +44 (0)20 89538228

**Sumitomo Electric Europe Ltd. (Italy Branch)**

Piazza Don E. Mapelli, 60 - 20099  
Sesto San Giovanni, Milano - Italy  
TEL: +39-02-496386-01  
FAX: +39-02-496386-25

**Sumitomo Electric Asia, Ltd.**

Room 2624-2637, 26/F.,  
Sun Hung Kai Centre,  
30 Harbour Road, Wanchai,  
Hong Kong  
TEL: +852-2576-0080  
FAX: +852-2576-6412

**Sumitomo Electric Device Innovations, Inc.**

1000 Kamisukiahara, showa-cho  
Nakakomagun, Yamanashi  
409-3883, Japan  
(Kokubo Industrial Park)  
TEL +81-55-275-4411  
FAX +81-55-275-9461

**Sumitomo Electric Industries, Ltd.**

**Head Office (Tokyo)**  
3-9-1, Shibaura, Minato-ku, Tokyo 108-8539,  
Japan  
TEL +81-3-6722-3283  
FAX +81-3-6722-3284

**CAUTION**

Sumitomo Electric Device Innovations, Inc. products contain **gallium arsenide (GaAs)** which can be hazardous to the human body and the environment. For safety, observe the following procedures:

- Do not put these products into the mouth.
- Do not alter the form of this product into a gas, powder, or liquid through burning, crushing, or chemical processing as these by-products are dangerous to the human body if inhaled, ingested, or swallowed.
- Observe government laws and company regulations when discarding this product. This product must be discarded in accordance with methods specified by applicable hazardous waste procedures.

Sumitomo Electric Device Innovations, Inc. reserves the right to change products and specifications without notice. The information does not convey any license under rights of Sumitomo Electric Device Innovations, Inc. or others.

© 2010 Sumitomo Electric Device Innovations, Inc.

