

### ● FEATURES

High Output Power: P<sub>1dB</sub>=39.0dBm (Typ.)  
 High Gain: G<sub>1dB</sub>=10.5dB (Typ.)  
 High PAE:  $\eta_{add}$ =35% (Typ.)  
 Broad Band: 6.4 to 7.2GHz  
 Internally matched  
 Plastic Package for SMT applications

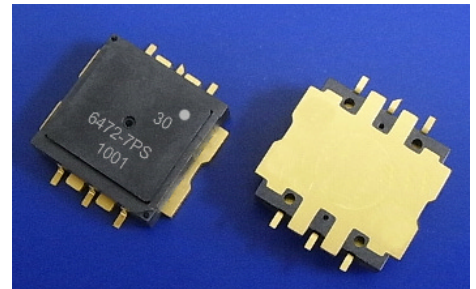

### ● DESCRIPTION

The ELM6472-7PS is a power GaAs FET that is internally matched for standard communication bands to provide optimum power and gain.

#### ABSOLUTE MAXIMUM RATING (Case Temperature T<sub>c</sub>=25 deg.C)

Item	Symbol	Rating	Unit
Drain-Source Voltage	V <sub>DS</sub>	15	V
Gate-Source Voltage	V <sub>GS</sub>	-5	V
Total Power Dissipation	P <sub>T</sub>	42.8	W
Storage Temperature	T <sub>STG</sub>	-40 to +125	deg.C
Channel Temperature	T <sub>CH</sub>	175	deg.C

#### RECOMMENDED OPERATING CONDITION (Case Temperature T<sub>c</sub>=25 deg.C)

Item	Symbol	Condition	Limit	Unit
DC Input Voltage	V <sub>DS</sub>		<10	V
Forward Gate Current	I <sub>GF</sub>	R <sub>G</sub> =100 ohm	<+16	mA
Reverse Gate Current	I <sub>GR</sub>	R <sub>G</sub> =100 ohm	>-2.2	mA
Channel Temperature	T <sub>CH</sub>		155	deg.C

#### ELECTRICAL CHARACTERISTICS (Case Temperature T<sub>c</sub>=25 deg.C)

Item	Symbol	Condition	Limit			Unit
			Min.	Typ.	Max.	
Drain Current	I <sub>DSS</sub>	V <sub>DS</sub> =5V, V <sub>GS</sub> =0V	-	3400	5200	mA
Trans conductance	gm	V <sub>DS</sub> =5V, I <sub>DS</sub> =2200mA	-	3400	-	mS
Pinch-off Voltage	V <sub>P</sub>	V <sub>DS</sub> =5V, I <sub>DS</sub> =170mA	-0.5	-1.5	-3.0	V
Gage-Source Breakdown Voltage	V <sub>GSO</sub>	I <sub>GS</sub> =170uA	-5.0	-	-	V
Output Power at 1dB G.C.P.	P <sub>1dB</sub>	V <sub>DS</sub> =10V I <sub>DS(DC)</sub> =2200mA(typ.) f=6.4 to 7.2 GHz	38.0	39.0	-	dBm
Power Gain at 1dB G.C.P.	G <sub>1dB</sub>		9.0	10.5	-	dB
Drain Current	I <sub>dsr</sub>		-	2200	2600	mA
Power Added Efficiency	$\eta_{add}$		-	35	-	%
Gain Flatness	$\Delta G$		-	-	1.2	dB
3 <sup>rd</sup> Order Inter Modulation Distortion	IM <sub>3</sub>	f=7.2GHz $\Delta f$ =10MHz, 2-tone Test P <sub>out</sub> =28.0dBm (S.C.L)	-40	-43	-	dBc
R <sub>th</sub>	R <sub>th</sub>	Channel to Case	-	2.5	3.0	deg.C/W
$\Delta T_{ch}$	$\Delta T_{ch}$	10V x I <sub>dsr</sub> x R <sub>th</sub>	-	-	80	deg.C

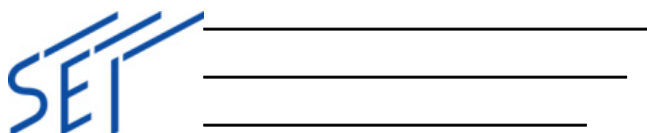

**ELM6472-7PS**  
**C-Band Internally Matched FET**

**CASE STYLE: I2C**

<b>ESD</b>	<b>Class 3 A</b>	<b>4000 to 8000V</b>
<b>MSL</b>	<b>2A</b>	<b>4 weeks after open the package</b>

**Note : Based on JEDEC JESD22-A114 (C=100pF, R=1500ohm)**

**Ordering Information**

<b>Model Type</b>	<b>MOQ</b>	<b>MOU</b>	<b>Packing Style</b>
ELM6472-7PS	15pcs	15pcs	15pcs Tray
ELM6472-7PST	500pcs	500pcs	24mm width Tape (500pcs/Reel)

\*MOQ stands for Minimum Order Quantity.

\*MOU stands for Minimum Order Unit size.

**Note**

- This device will not be delivered with test data but tested pass/fail 100% against DC and RF specifications.
- NO liquid cleaning process is suitable for this device. (including de-ionized water or solvent)

● RF Characteristics

Power Derating Curve

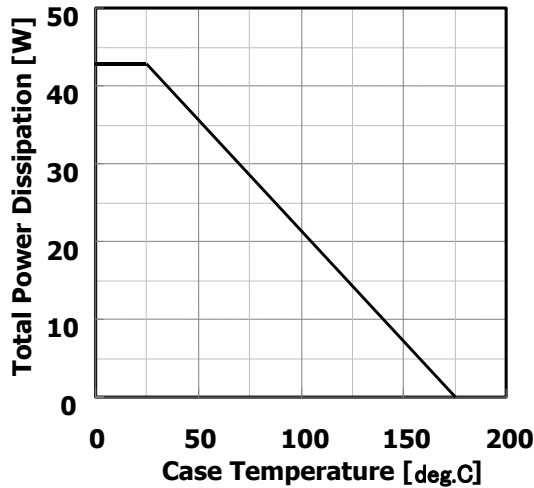

Input Power vs. Output Power, Power Added Efficiency  
 $V_{DS}=10V, I_{DS(DC)}=2200mA$

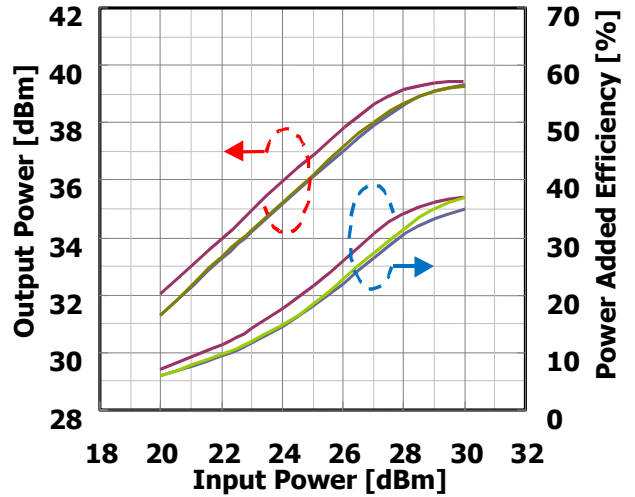

— 6.4 GHz — 6.8 GHz — 7.2 GHz

Output Power vs. Frequency  
 $V_{DS}=10V, I_{DS(DC)}=2200mA$

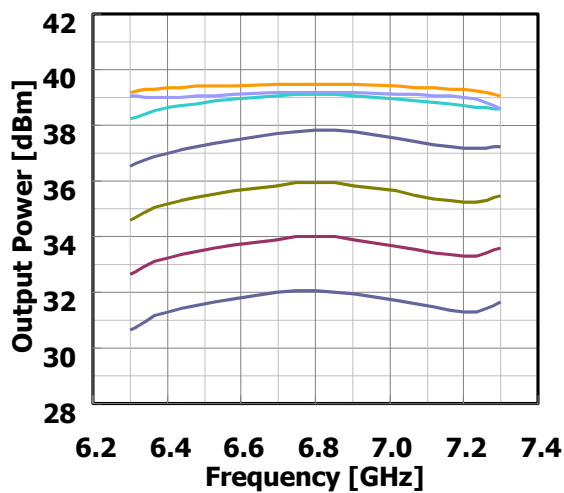

— 20 dBm — 22 dBm — 24 dBm — 26 dBm  
 — 28 dBm — 30 dBm — P1dB

IMD vs. Output Power  
 $V_{DS}=10V, I_{DS(DC)}=2200mA$

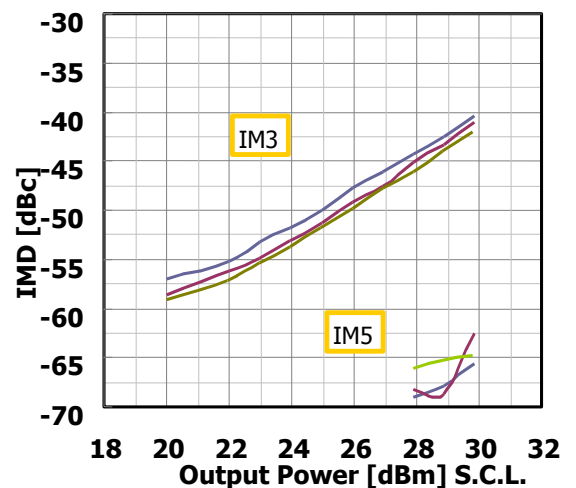

— 6.4 GHz — 6.8 GHz — 7.2 GHz

**Input Power vs. Output Power, Power Added Efficiency by Drain Voltage**  
 $I_{DS(DC)}=2200\text{mA}$  @6.4GHz

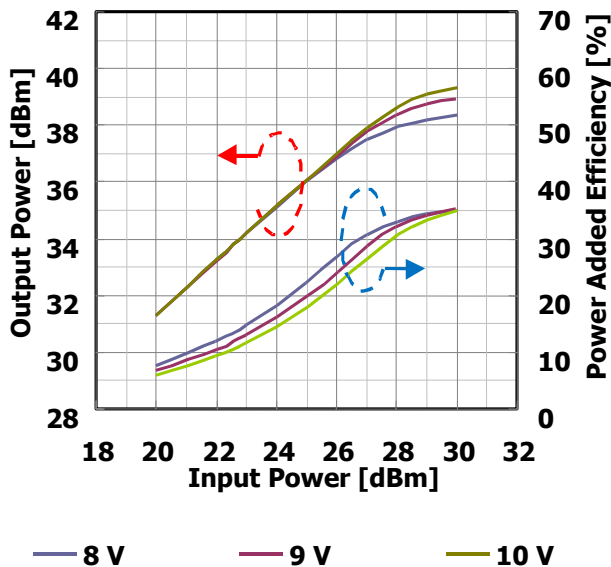

**Input Power vs. Output Power, Power Added Efficiency by Drain Voltage**  
 $I_{DS(DC)}=2200\text{mA}$  @6.8GHz

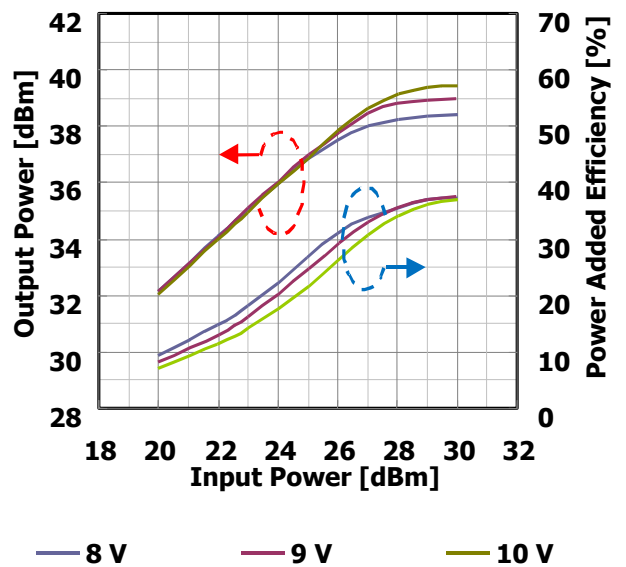

**Input Power vs. Output Power, Power Added Efficiency by Drain Voltage**  
 $I_{DS(DC)}=2200\text{mA}$  @7.2GHz

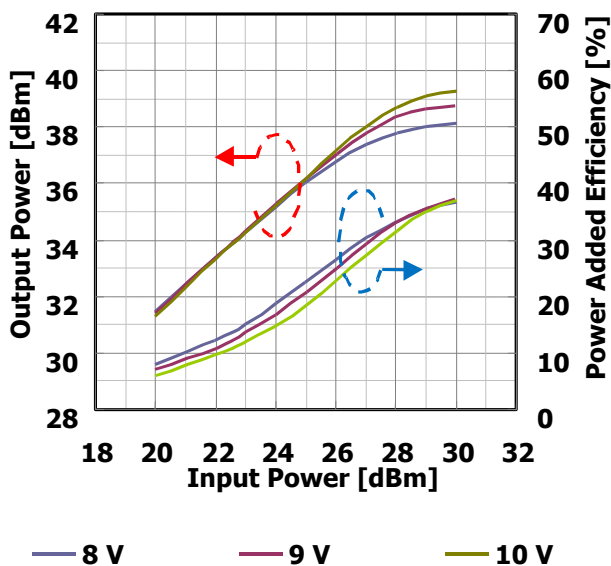

**Input Power vs. Output Power, Power Added Efficiency by Quiescent Drain Current**  
 $V_{DS}=10V$  @6.4GHz

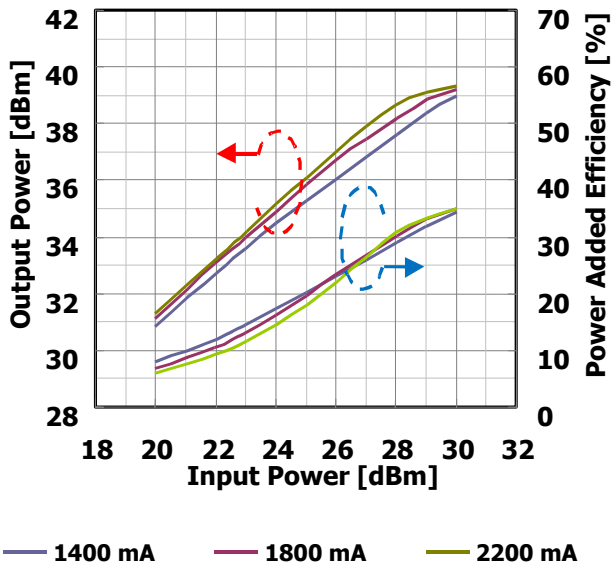

**Input Power vs. Output Power, Power Added Efficiency by Quiescent Drain Current**  
 $V_{DS}=10V$  @6.8GHz

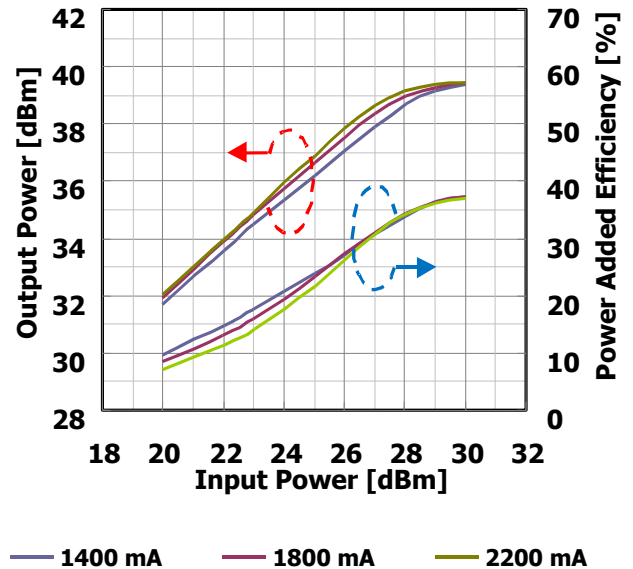

**Input Power vs. Output Power, Power Added Efficiency by Quiescent Drain Current**  
 $V_{DS}=10V$  @7.2GHz

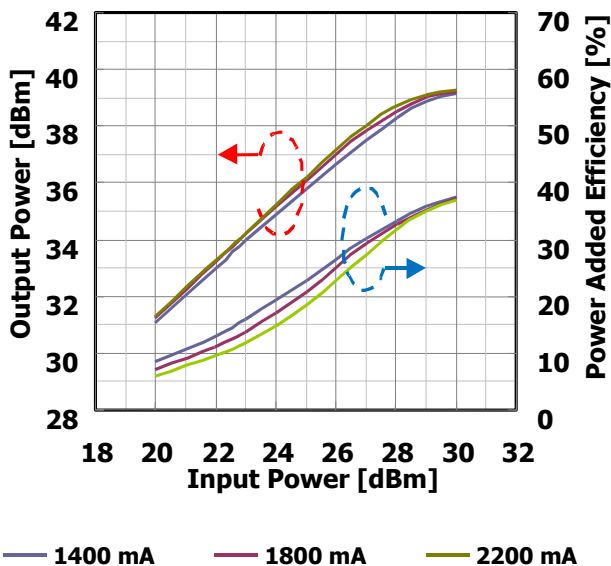

**Input Power vs. Output Power, Power Added Efficiency by Case Temperature**  
 $V_{DS}=10V$   $I_{DS(DC)}=2200mA$  @6.4GHz

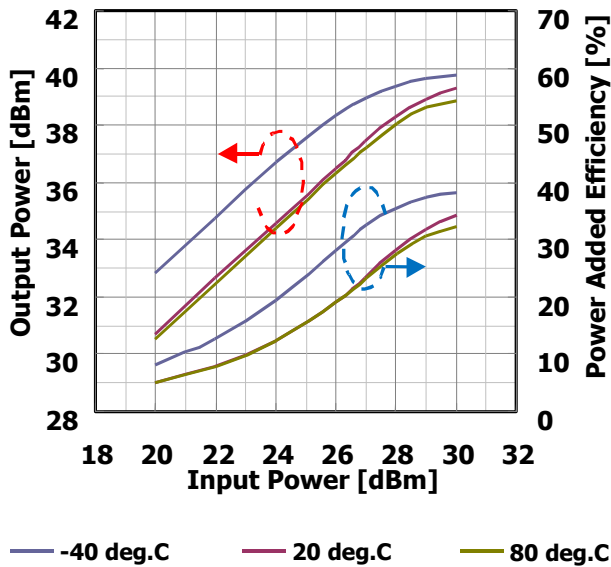

**Input Power vs. Output Power, Power Added Efficiency by Case Temperature**  
 $V_{DS}=10V$   $I_{DS(DC)}=2200mA$  @6.8GHz

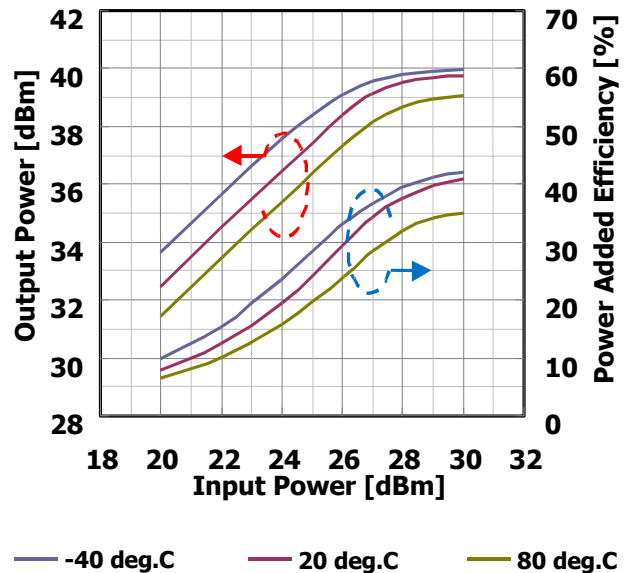

**Input Power vs. Output Power, Power Added Efficiency by Case Temperature**  
 $V_{DS}=10V$   $I_{DS(DC)}=2200mA$  @7.2GHz

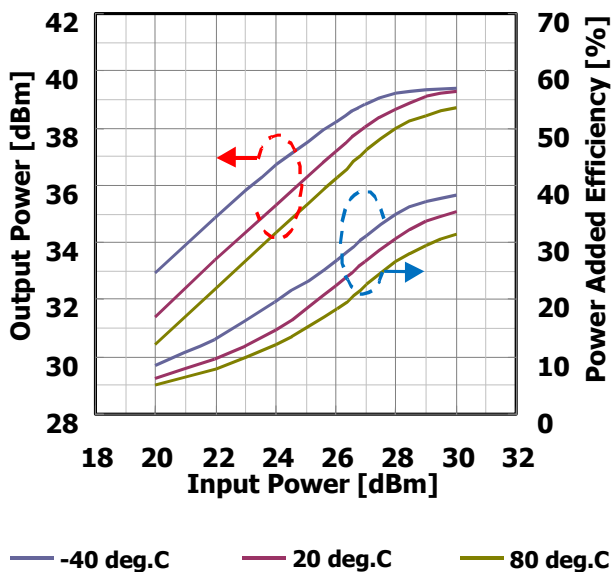

**IMD Performance vs. Output Power by Drain Voltage**  
 $I_{DS(DC)}=2200\text{mA}$  @6.4GHz

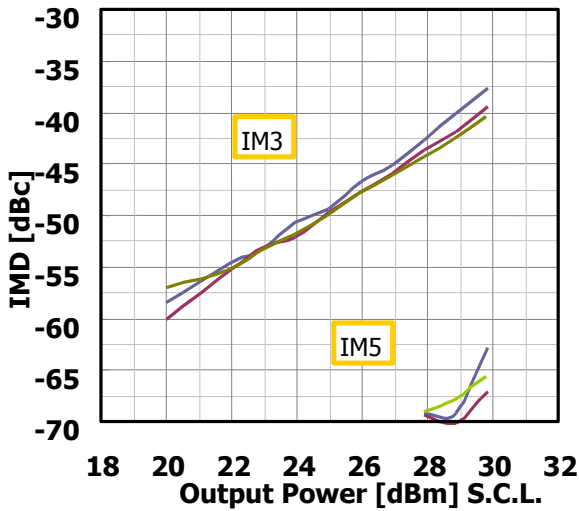

— 8 V    — 9 V    — 10 V

**IMD Performance vs. Output Power by Drain Voltage**  
 $I_{DS(DC)}=2200\text{mA}$  @6.8GHz

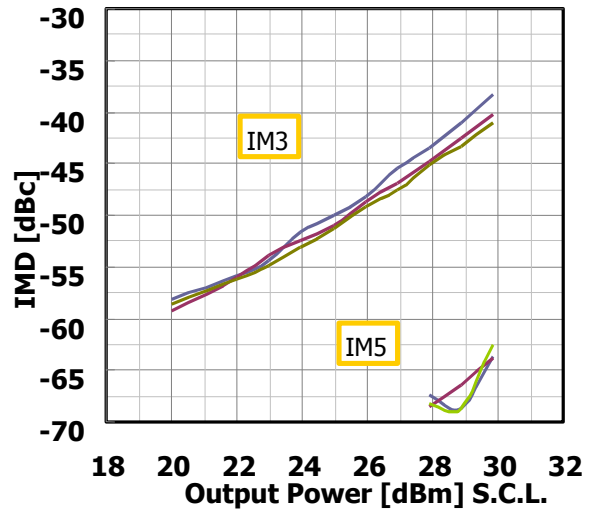

— 8 V    — 9 V    — 10 V

**IMD Performance vs. Output Power by Drain Voltage**  
 $I_{DS(DC)}=2200\text{mA}$  @7.2GHz

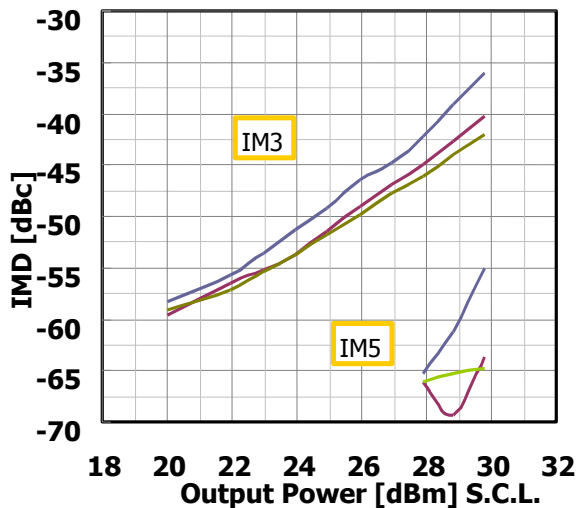

— 8 V    — 9 V    — 10 V

**IMD Performance vs. Output Power by Quiescent Drain Current**  
 $V_{DS}=10V$  @6.4GHz

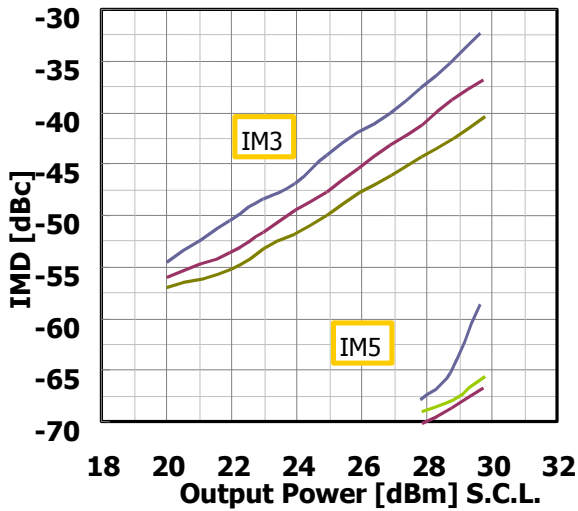

— 1400 mA — 1800 mA — 2200 mA

**IMD Performance vs. Output Power by Quiescent Drain Current**  
 $V_{DS}=10V$  @6.8GHz

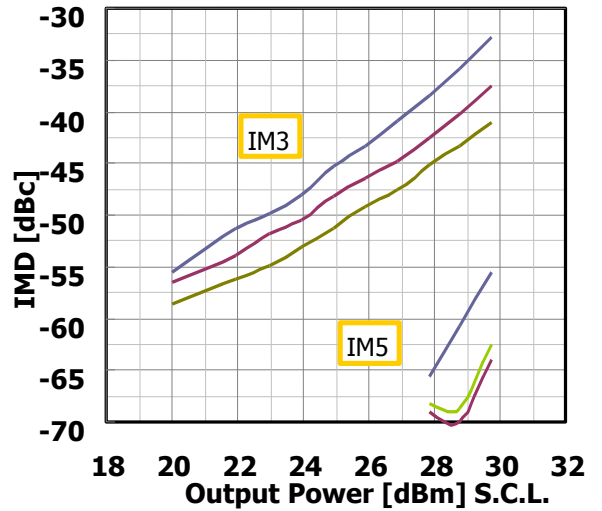

— 1400 mA — 1800 mA — 2200 mA

**IMD Performance vs. Output Power by Quiescent Drain Current**  
 $V_{DS}=10V$  @7.2GHz

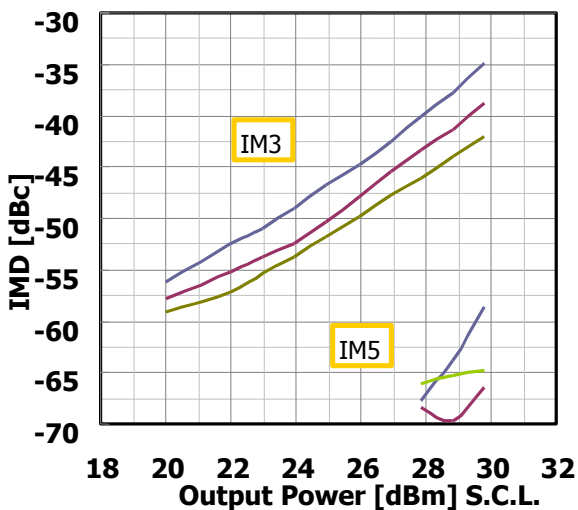

— 1400 mA — 1800 mA — 2200 mA



**IMD Performance vs. Output Power by Case Temperature**  
 $V_{DS}=10V$   $I_{DS(DC)}=2200mA$  @6.4GHz

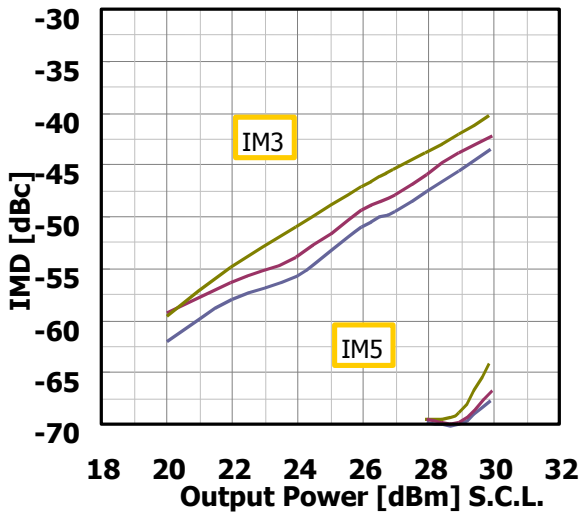

— -40 deg.C — 20 deg.C — 80 deg.C

**IMD Performance vs. Output Power by Case Temperature**  
 $V_{DS}=10V$   $I_{DS(DC)}=2200mA$  @6.8GHz

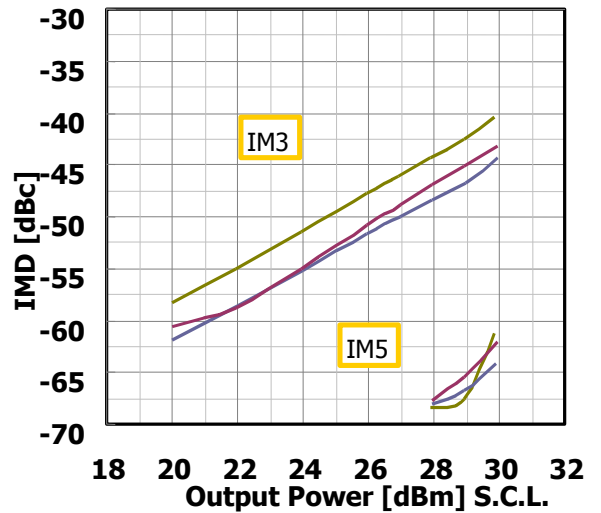

— -40 deg.C — 20 deg.C — 80 deg.C

**IMD Performance vs. Output Power by Case Temperature**  
 $V_{DS}=10V$   $I_{DS(DC)}=2200mA$  @7.2GHz

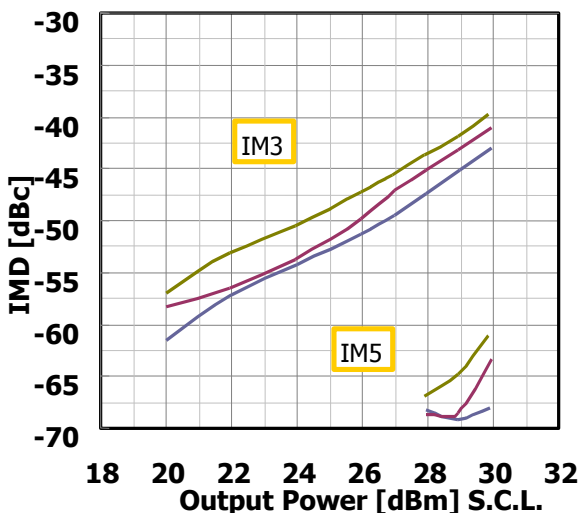

— -40 deg.C — 20 deg.C — 80 deg.C

● S-Parameter

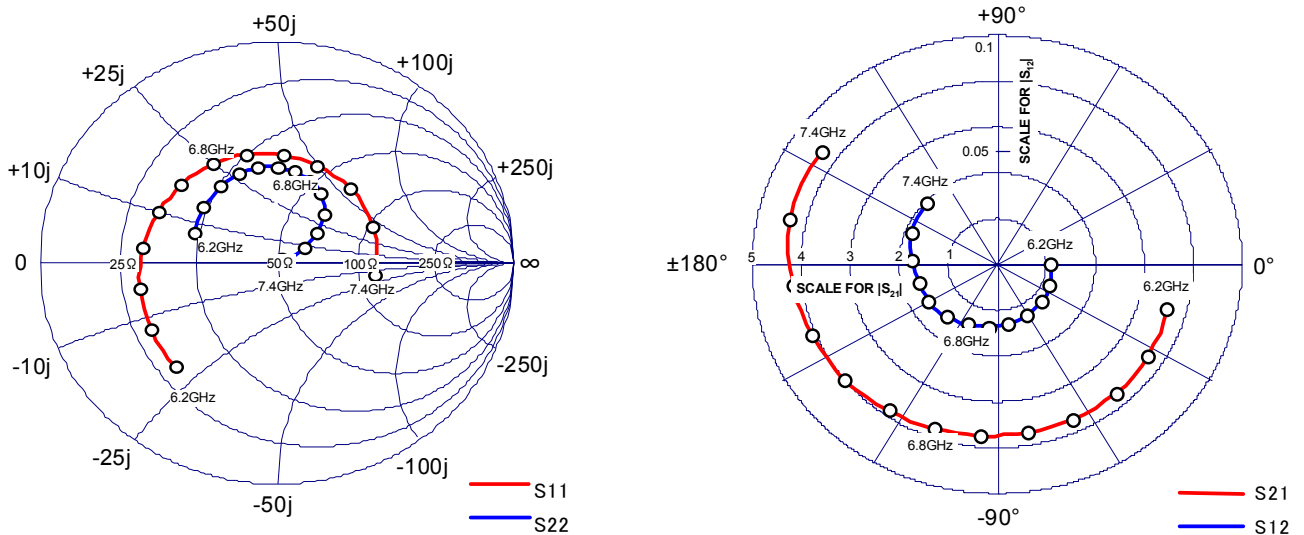

Frequency (MHz)	S11		S21		S12		S22	
	MAG	ANG	MAG	ANG	MAG	ANG	MAG	ANG
6200	0.638	-132.2	3.583	-15.9	0.022	-0.3	0.369	159.2
6300	0.610	-150.1	3.689	-33.1	0.023	-22.1	0.395	140.6
6400	0.587	-168.6	3.721	-49.3	0.024	-42.2	0.417	125.4
6500	0.567	173.1	3.715	-65.2	0.025	-61.4	0.431	112.2
6600	0.549	155.3	3.721	-80.2	0.026	-80.0	0.436	100.4
6700	0.535	138.4	3.756	-95.1	0.028	-97.5	0.431	89.8
6800	0.521	121.7	3.795	-109.7	0.029	-114.6	0.419	80.1
6900	0.507	104.9	3.876	-124.8	0.031	-131.3	0.397	70.0
7000	0.489	87.2	4.006	-140.9	0.032	-150.0	0.360	58.7
7100	0.469	68.9	4.061	-157.4	0.033	-165.8	0.293	47.6
7200	0.456	47.4	4.182	-174.1	0.035	177.8	0.217	38.8
7300	0.434	21.3	4.337	166.8	0.037	158.8	0.130	29.6
7400	0.413	-8.5	4.332	145.5	0.039	136.9	0.022	36.9

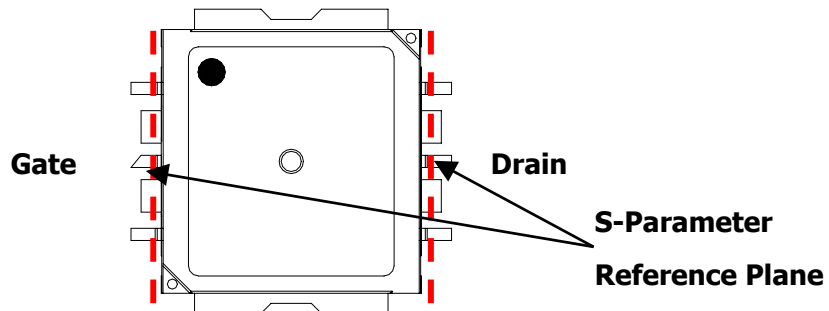

● **Package Out Line**

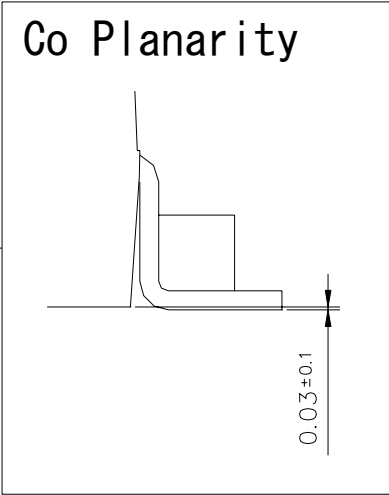
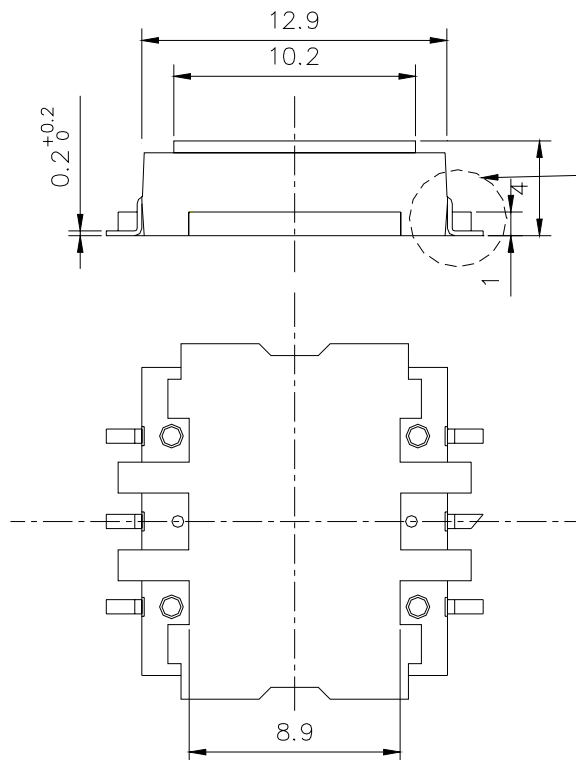
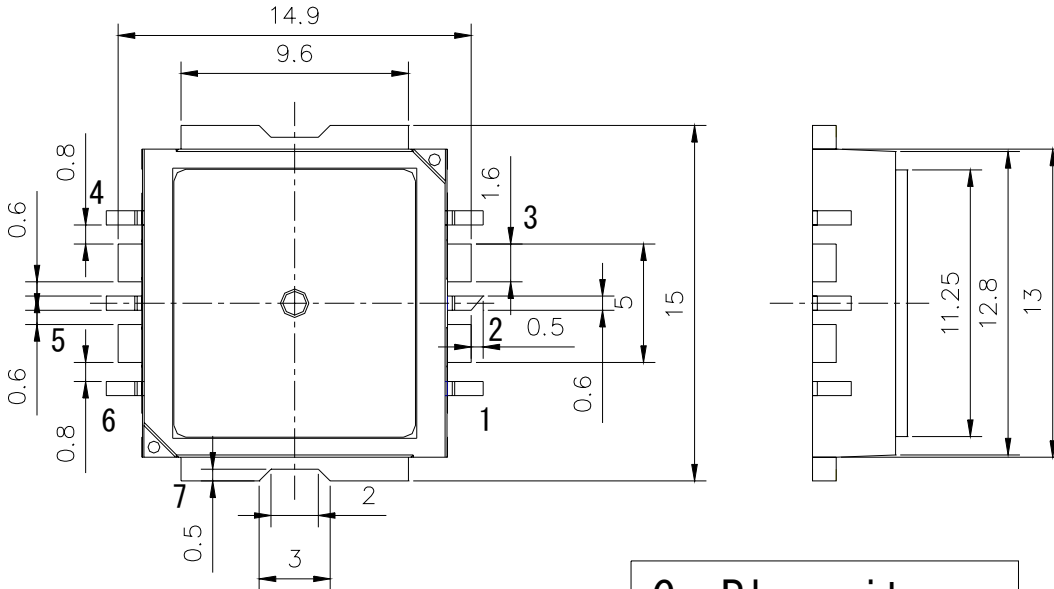

**Pin Assignments**

1	: NC
2	: Gate
3	: NC
4	: NC
5	: Drain
6	: NC
7	: Source

● **PCB Pads and Solder-Resist Pattern**

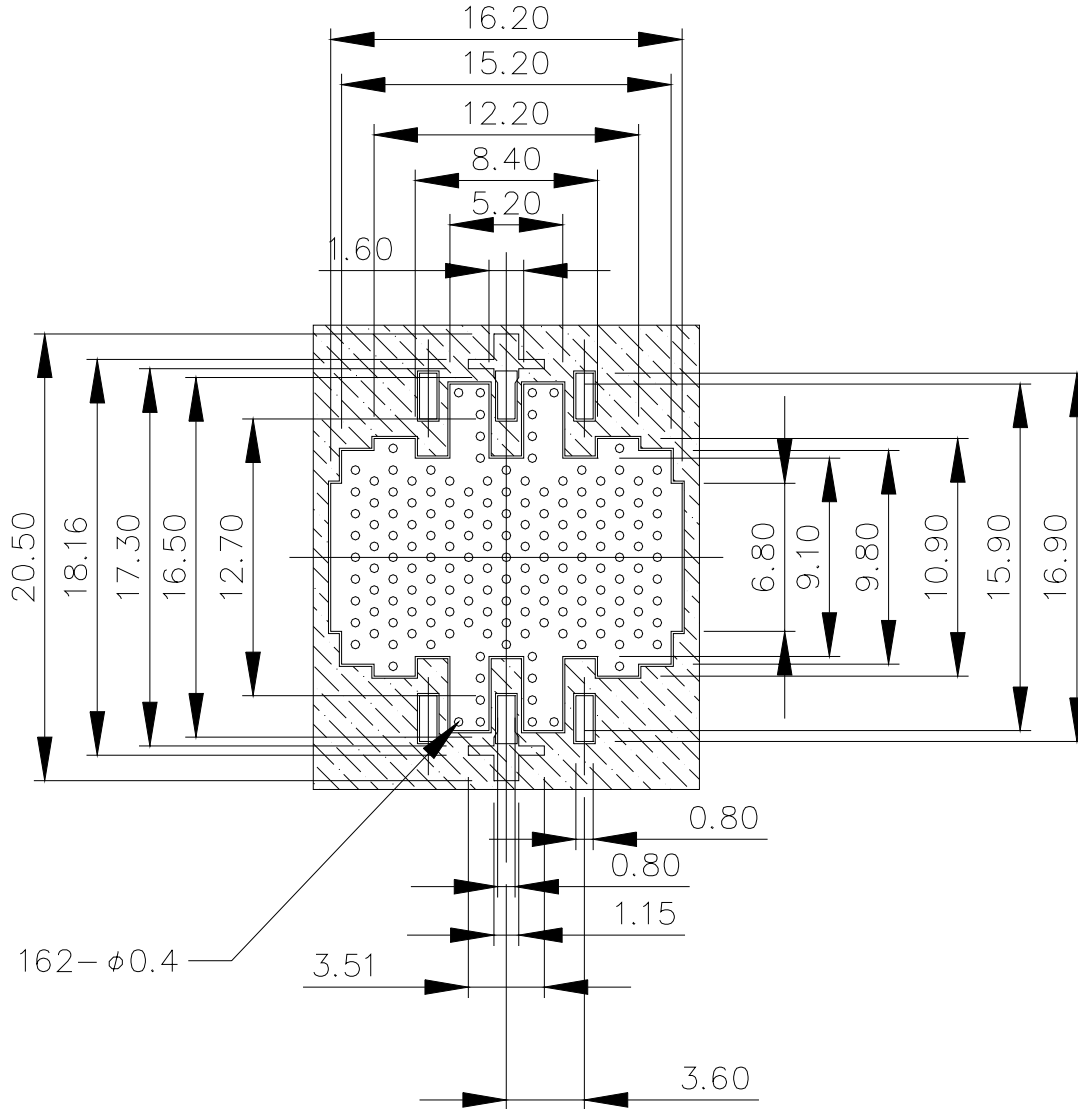

Notes :

- Laminate : Rogers Corporation R04003, Thickness  $t=0.508\text{mm}$ , Cu Foil  $18\mu\text{m}$ .  
 Finish to copper foil : Ni  $0.1\mu\text{m}$  min. / Au  $0.1\mu\text{m}$  (Both side).
-  : Resist

● **Marking and Tape/Reel Configuration**

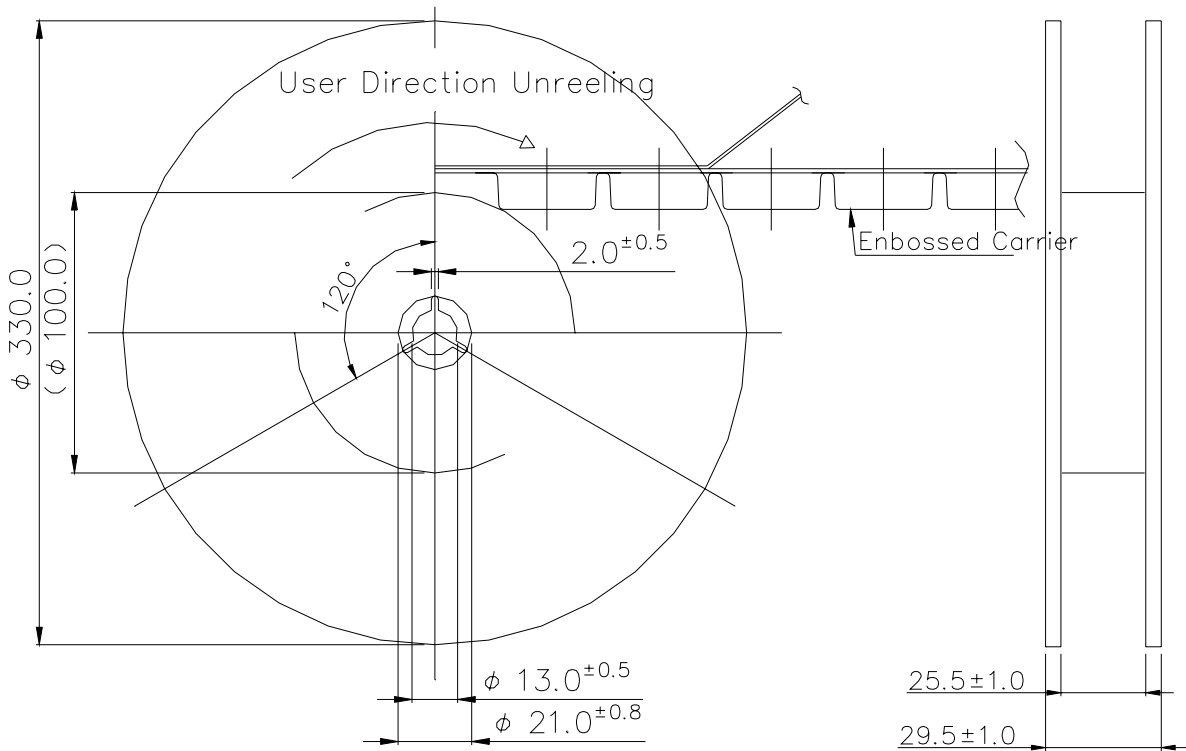
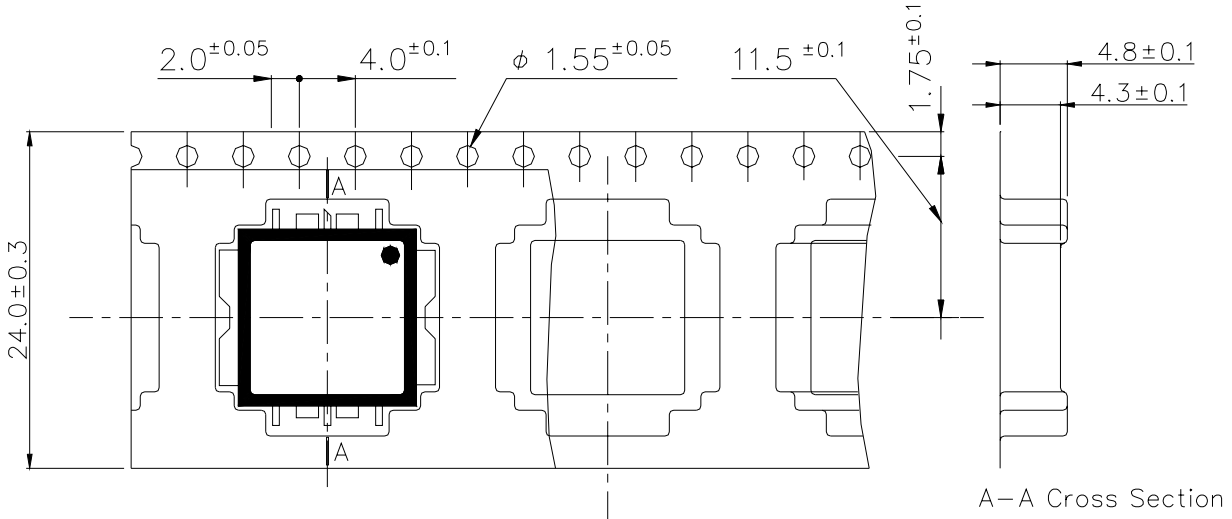

Quantity: 500pcs/tape  
 Tape Material: Conductive PS

(unit in mm)

● **Mounting Instructions for Package for Lead-free solder**

**Mounting Condition**

For soldering, Lead-free solder (Sn-3.0Ag-0.5Cu)\*1 which is no liquid cleaning type shall be used.

1. The example solder is a tin-rich alloy with 3.0% silver and 0.5% copper, often called Sn 96 for its approximate Tin content.
2. A rosin type flux with chlorine content of 0.2% or less shall be used. The rosin flux with low halogen content is recommended. When soldering, use the following time/ temperature profile with any of the methods listed for acceptable solder joints.
3. Make sure the devices have been properly prepared with flux prior soldering.

**\*Reflow soldering method (Infrared reflow / Heat circulation reflow / Hot plate reflow);**

Limit solder to 3 reflow cycles because resin is used in the modules manufacturing process.

Excessive reflow will effect the resin resulting in a potential failure or latent defect.

The recommended reflow temperature profile is shown below. The temperature of the reflow profile must be measured at the device lead.

● **Reflow temperature profile and condition:**

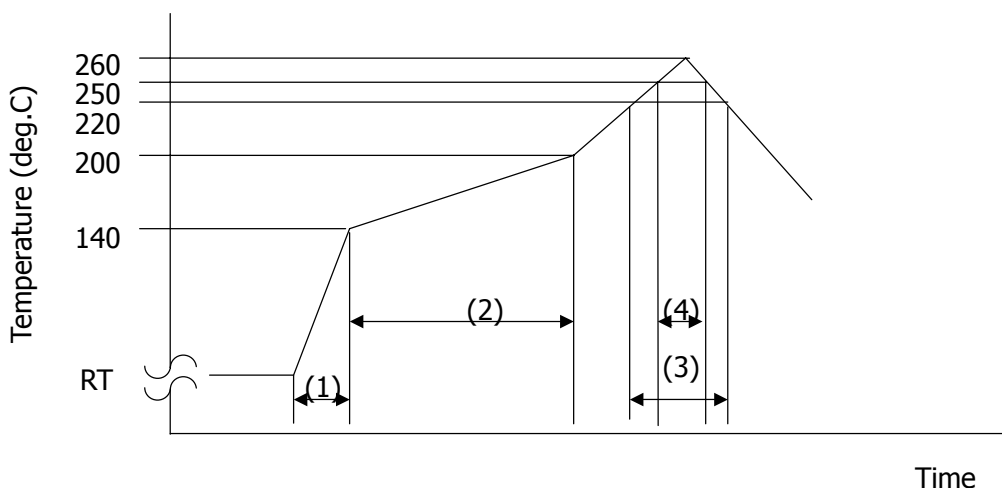

- (1). Temperature rise: 3 deg-C/seconds.
- (2). Preheating: 150 – 200 deg.C, 60 - 180seconds.
- (3). Main heating: 220 deg.C, 60 seconds max.
- (4). Main heating: 260 deg.C max., more than 250 deg.C, 20 - 40 seconds max.

\* Measurement point: Device Heat-sink (Source Pin).

1. The above-recommended conditions were confirmed using the manufacturer’s equipment and materials. However, when soldering these products, the soldering condition should be verified by customer using their own particular equipment and materials.

● **Cleaning**

Avoid washing of the device after soldering by reflow method due to the risk of liquid absorption by the resin used in this part.

**Humidity Lifetime for ELMxxxx-7PST**

The following graph shows the effect of moisture on lifetime (moisture resistance) for the **ELMxxxx-7PST**. Each graph indicates the MTTF and failure rate prediction (Confidential Level = 90 %) which calculated from the results of highly accelerated temperature and humidity stress test (HAST).

Representative of device type : ELM7179-7PST

Subject of device type : ELMxxxx-7PST

**Field environmental conditions for operation**

If the **ELMxxxx-7PST** is installed in a non-hermetic environment, please refer to the following recommendations and notes for design with, and assembly and use of our products.

- Note 1. When drain current cuts off, it should be cut off by drain bias, and not cut off by gate bias only. The humidity lifetime becomes shorter in case of the gate-only cut off operation due to electric field strength interacting with humidity.
- Note 2. **ELMxxxx-7PST** should be used under the environment conditions of no dew condensation. These plots do not apply in the case of liquid absorbed into the resin, whether applied to the part in assembly or as condensate in the application.

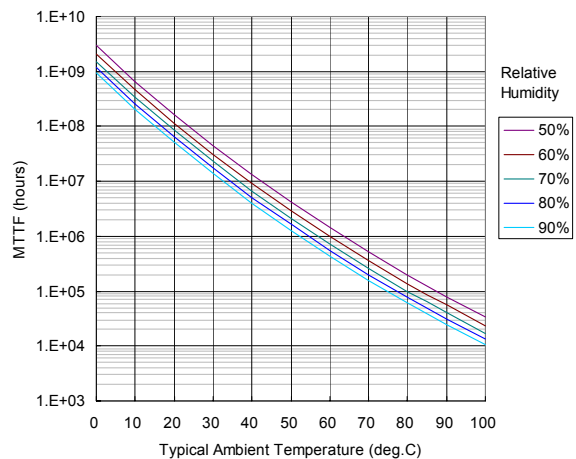
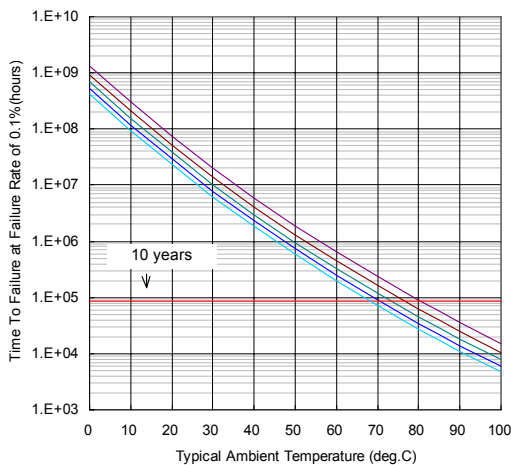

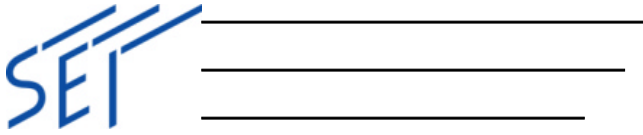

**ELM6472-7PS**  
**C-Band Internally Matched FET**

**For further information please contact:**

<http://global-sei.com/Electro-optic/about/office.html>

**CAUTION**

This product contains gallium arsenide (GaAs) which can be hazardous to the human body and the environment.

For safety, observe the following procedures:

- Do not put these products into the mouth.
- Do not alter the form of this product into a gas, powder, or liquid through burning, crushing, or chemical processing as these by products are dangerous to the human body if inhaled, ingested, or swallowed.
- Observe government laws and company regulations when discarding this product. This product must be discarded in accordance with methods specified by applicable hazardous waste procedures.